

Development of Roller-Based Interior Wall Painting Robot

Mohamed T. Sorour, Mohamed A. Abdellatif, Ahmed A. Ramadan, and Ahmed A. Abo-Ismael

Abstract—This paper describes the development of an autonomous robot for painting the interior walls of buildings. The robot consists of a painting arm with an end effector roller that scans the walls vertically and a mobile platform to give horizontal feed to paint the whole area of the wall. The painting arm has a planar two-link mechanism with two joints. Joints are driven from a stepping motor through a ball screw-nut mechanism. Four ultrasonic sensors are attached to the mobile platform and used to maintain a certain distance from the facing wall and to avoid collision with side walls. When settled on adjusted distance from the wall, the controller starts the painting process autonomously. Simplicity, relatively low weight and short painting time were considered in our design. Different modules constituting the robot have been separately tested then integrated. Experiments have shown successfulness of the robot in its intended tasks.

Keywords—Automated roller painting, Construction robots, Mobile robots, service robots, two link planar manipulator

I. INTRODUCTION

DESPITE the advances in robotics and its wide spreading applications, interior wall painting has shared little in research activities. The painting chemicals can cause hazards to the human painters such as eye and respiratory system problems. Also the nature of painting procedure that requires repeated work and hand rising makes it boring, time and effort consuming. These factors motivate the development of an automated robotic painting system. There have been few research projects in the literature but they did not produce a mature system acceptable by the market yet.

Warszawsky [1] and Kahane [2], developed a robot for interior finishing tasks named “TAMIR”, and was used in four interior finishing tasks namely; painting, plastering, tiling and masonry. The robot has 6 DOF (Degrees Of Freedom) with an average reach of 1.7m and end effector payload of 30 kg. It is mounted on 3 wheeled mobile robot which gives another 3 DOF. The platform moves between workstations and at each one it deploys four stabilizing legs. The robot arm used is the S-700 model made by General Motors, of 500 Kg weight.

Also a methodology for human-robot integration in construction site has been developed claimed to be profitable of introducing robots in finishing tasks with promising

M. T. Sorour is a master candidate at the Egypt-Japan University for Science and Technology, New Borg-El-Arab city, Alexandria, Egypt (phone: 002010-629-3973; Zip: 21934; e-mail: mohamed.sorour@ejust.edu.eg).

M. A. Abdellatif is an associate professor with the Egypt-Japan University of Science and Technology, New Borg-El-Arab city, Alexandria, Egypt (e-mail: mohamed.abdellatif@ejust.edu.eg).

A. A. Ramadan is an assistant professor on leave of Tanta University and is currently with the Egypt-Japan University for Science and Technology, New Borg-El-Arab city, Alexandria, Egypt (e-mail: ahmed.ramadan@ejust.edu.eg).

A. A. Abo-Ismael, is a full professor with the Egypt-Japan University of Science and Technology, New Borg-El-Arab city, Alexandria, Egypt (e-mail: aboismail@ejust.edu.eg).

numbers. In case of wall painting, a reduction in total painting time of about 70% was reached, and can be increased by up to 20% if additionally ceil painting is involved.

A scaled down robot setup for interior wall painting together with a multicolor spraying end tool were implemented by Naticchia [3], [4], [5], and claimed to work in full scale without reduction in performance. The robot named “Pollock#1” had 6 DOF, a nominal reach of 0.4 m and a maximum payload of 4kg. It should be fixed on a 2 DOF hexapod for horizontal movement but was not actually used in experiments.

A full scale mechanism for ceil painting was introduced by Aris [6]. It had 3DOF without considering those of the platform, a working envelope of (84cm by 72 cm by 122 cm). Significant improvement in painting time and cost had been reached where 46 m² of ceil were painted in 3.5 hours which is 1.5 times faster than manual painting.

The implemented robot [1] can't be used in residential buildings due to its heavy weight that is over 500 kg. The robot in [6] is huge, has small work space and paints only the ceiling. Spray painting used in [3] will result in increased system weight which will impair the system portability.

Therefore, we believe that the current state of the art in wall painting robots is not matured and a need for a light weight and simple system still exists to attract potential construction and service companies together with regular house owners.

Moreover all of the previously conducted researches have focused only on spray as the main painting tool. Spray painting was preferred over roller painting, due to two reasons, namely the speed of spray is fast compared to roller and using roller will require force feedback which complicates the control.

In this work, a full scale robot is described consisting of a 2 DOF robotic painting arm and a 3 DOF mobile platform. Using the roller instead of spray reduces the cost significantly since spray gun and its accessories are expensive. Light weight is achieved here by using a light weight two link robotic arm with new joint actuation mechanism. This mechanism is inspired from hydraulic cylinder actuation in heavy machinery and has decreased the overall robot weight significantly. It has the advantage of strong and accurate actuation due to the use of ball screw-nut. Also, a four wheeled mobile platform with a new idle wheel attachment have been introduced and claimed to be easier in control. The paper is arranged as follows, the next section presents the mechanical design and analysis of the two link planar manipulator. Section III, describes the mechanical design of the mobile platform and the principle of operation. In section IV, the control algorithm of automated painting is presented. Then implementation and experimental results are given in section V. Conclusions are finally given in Section VI.

II. PAINTING ARM DESIGN

The long reach of 2.7 m imposes the need of the serial link arm shown in Fig.1. But serial link robot arm with such long reach will require large actuating torques and will exhibit end effector vibrations. And here comes the new joint actuation mechanism. Using roller as the painting method will require continuous contact with the wall, which will induce complexity to the control system if not solved mechanically. This is done by using spring compensation. In the following subsections further analysis is provided.

A. Robotic Arm Kinematics and Dynamics

First we should determine the motion profile of the roller on the wall. For the purpose of decreasing vibration in the structure, a fifth order motion profile has been utilized, whose coefficient are calculated according to the conditions provided in Table I and whose equation is given by:

$$P_y = 148.828125 \times 10^{-9}t^5 - 14882.8125 \times 10^{-9}t^4 + 396875 \times 10^{-9}t^3 - 0.14 \quad (1)$$

TABLE I
 INITIAL AND FINAL CONDITIONS OF TRAJECTORY

$P_y(0)$	$P_y(40)$	$V_y(0)$	$V_y(40)$	$A_y(0)$	$A_y(40)$
-0.14	2.5	0	0	0	0

where, P_y , V_y , A_y are the position, velocity and acceleration in Y-axis respectively. A paint strip should be finished in 40 seconds for a single stroke on the wall, either up or down. The general equations describing the kinematics and dynamics of two link manipulators are provided in [7], [8]. Specifications of the designed robotic arm are presented in Table II. Corresponding joint's angular position and velocity profiles of the two joints constituting the arm together with the torque requirements are presented in Fig.2

TABLE II
 PAINTING ARM SPECIFICATIONS

Symbol	Quantity	Value
p_x	distance between center of platform and wall	-0.865 m
Y	distance between center of platform and ground	-0.24 m
m_1	mass of link 1	6.2 Kg
m_2	mass of link 2	3.6 Kg
cg_1	distance between joint 1 and center of mass of link 1	0.732 m
cg_2	distance between joint 2 and center of mass of link 2	0.578 m
a_1	length of link 1	1.33 m
a_2	length of link 2	1.415 m
I_1	mass moment of inertia of link 1	1.17 Kg. m ²
I_2	mass moment of inertia of link 2	0.604 Kg. m ²

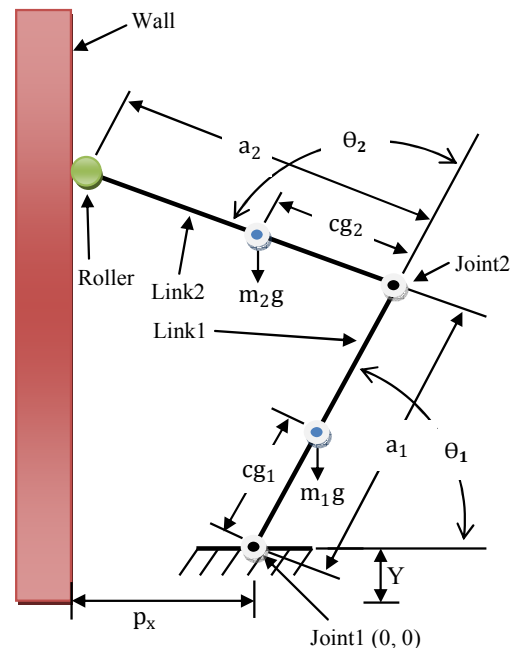
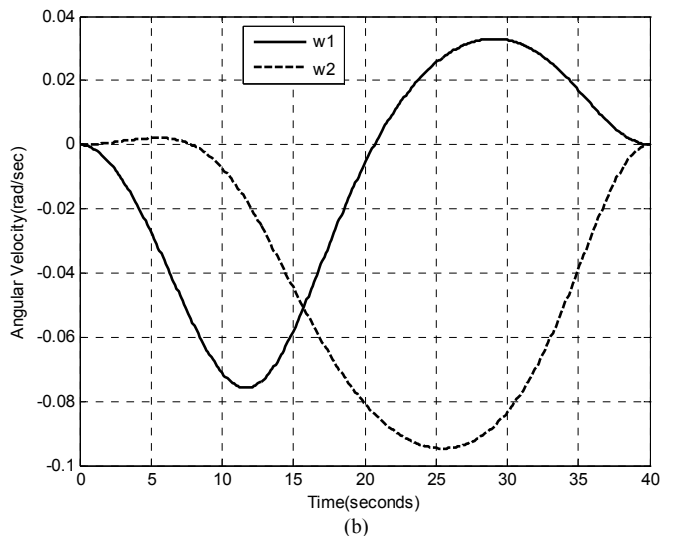
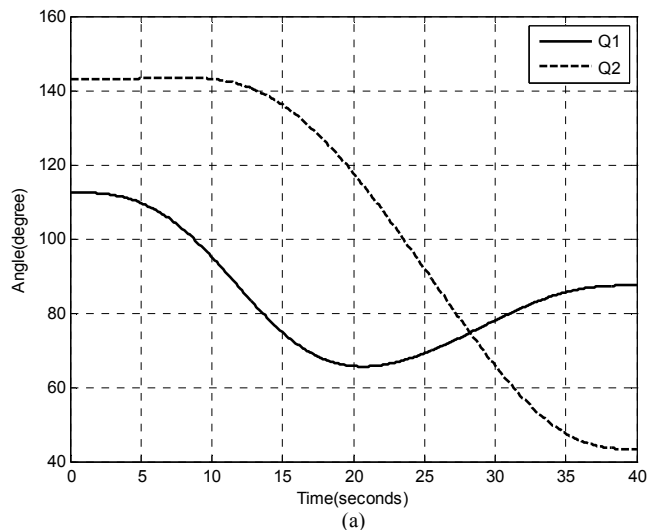

Fig. 1 Roller-based Wall Painting Robot in concept



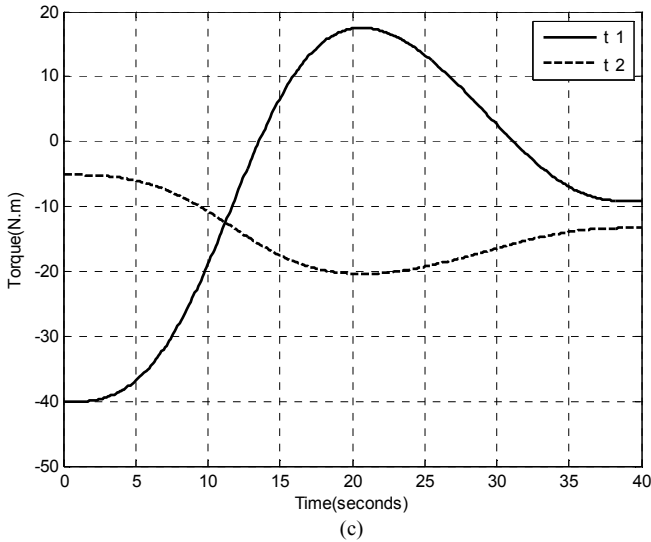

Fig. 2 Joint space motion profile and torque requirements.(a) Angular positions, (b) Angular velocities, (c) Torque required by joints

B. New Joint Actuation Mechanism

A very common problem in robotic arm implementation is the problem of drives. Using direct drive has the advantage of accurate control but low output torques can be obtained and so the arm is not powerful. On the other hand introducing gear trains enhances the powerfulness of the arm, but have the disadvantage of gear backlash and its nonlinearity. In the mechanism shown in Fig.3 we use ball screw-nut system to give us both advantages. Firstly the arm is powerful due to the mechanical advantage of the screw, where little amount of torque can generate large value of axial force. Secondly it is accurate, since the use of ball screw whose accuracy is selectable. End effector vibrations have been significantly decreased by the use of this mechanism due to decreasing the arm length between the end-effector and the joint. This mechanism is inspired by hydraulic cylinder actuator in heavy machinery. It is also important to point out that this mechanism have the drawback of being relatively slow, but usually low angular speeds are required in driving robotic arms.

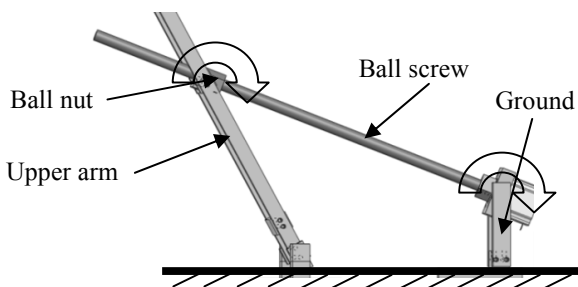

Fig. 3 Hydraulic cylinder actuation in heavy machinery inspired drive mechanism

C. Drive Kinematics

Presented below the relation between the required joint angular velocities ω_1, ω_2 and the corresponding motor velocities N_{m1}, N_{m2} to achieve them. This is done by studying

what is called the working triangle in the joint driving mechanism.

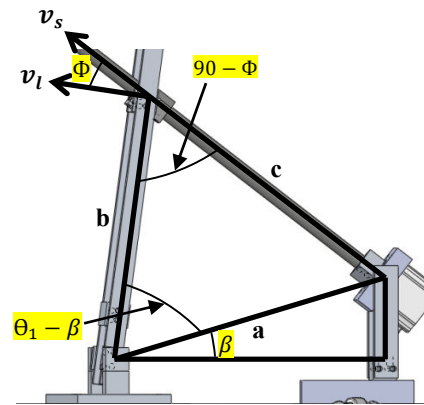

Fig. 4 Working triangle of first joint

In the working triangle shown in Fig.4, $a = 0.3075\text{m}$, $b = 0.275\text{m}$, $\beta = 18^\circ$ which are constants based on the geometry of the joint actuating mechanism. v_l is the linear velocity of the point of fixation of the ball nut, v_s is the linear velocity of the screw and Φ is the angle separating the vector of both. Simple analysis leads to:

$$N_{m1} = \frac{60b\omega_1 \cos(\Phi)}{\text{lead}} \quad (2)$$

where N_{m1} is the speed of the first joint actuating motor in r.p.m, ω_1 is based on trajectory.

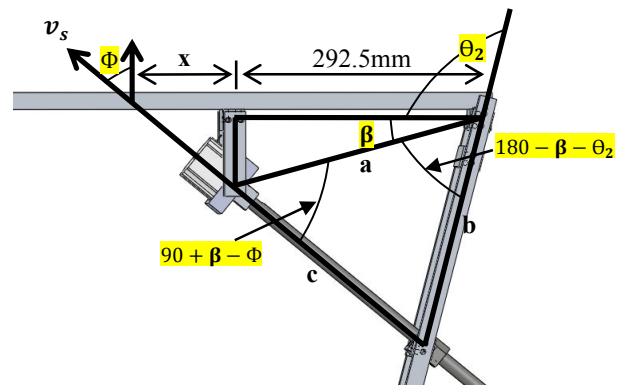

Fig. 5 Working triangle of second joint

Fig.5 shows the working triangle of the second joint, there are some differences with the first joint analysis. Here the motor has to rotate with the second link to avoid collision between the ball screw and the wall. Also there exists an extra variable x which is the distance from the motor fixation to the point of intersection of linear velocities. Similar approach is used for the second joint analysis and yields:

$$N_{m2} = \frac{60 \left[0.2925 + \frac{0.0775}{\tan(90 - \Phi)} \right] \omega_2 \cos(\Phi)}{\text{lead}} \quad (3)$$

where, $a = 0.2925\text{m}$, $b = 0.275\text{m}$, $\beta = 14.84^\circ$. Eq. (2) and (3) relate motor velocity requirement with time and are shown in Fig.6.

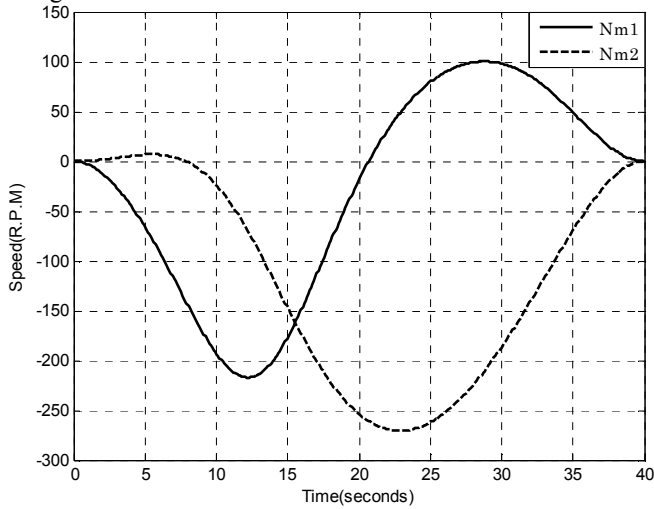

Fig. 6 Driving motors velocity profile

Required actuation torque of both motors is shown in Fig.7. As shown great reduction in torque requirement from 40 N.m to about 0.16 N.m has been achieved. Using this mechanism the reduction ratio have reached 250, while its weight doesn't exceed 2.5 kg which is very light when compared to any direct drive system that can generate the same value of maximum torque. Thanks to this mechanism, it is possible to develop a robotic arm with low weight.

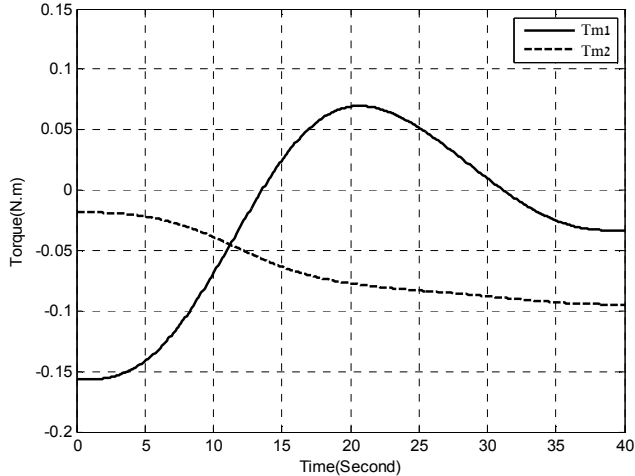

Fig. 7 Driving motors torque requirements

D.Spring Compensation

In order to avoid complexity of the control system as a result of contact necessity between the roller and the wall, we have to maintain contact mechanically and exclude its burden from the control system. Primary experiments have shown a maximum deviation of 2cm from the required trajectory in x-axis, that is defined by $p_x = -0.865\text{m}$. This results from using open loop control and inaccuracy in the model. The additional compression spring shown in Fig.8 is used to compensate for this effect and to assure wall-roller contact. The spring has a total compression length of 8cm and is initially pre-compressed by a length of 3cm, so that it can

compensate for both the positive and negative error in p_x trajectory; 3cm till free length and 5cm till max compression length.

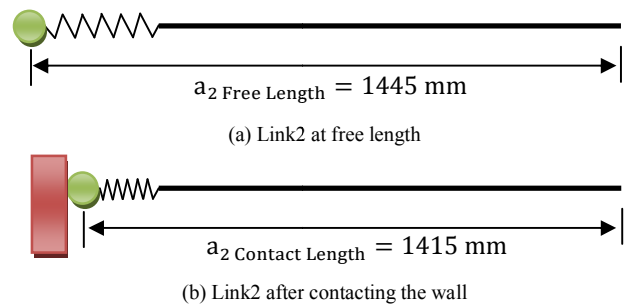

Fig. 8 Variable length link 2 (a) Free length before contacting the wall, (b) Contact length with 3cm pre-compression

III. MOBILE PLATFORM DESIGN

The robot's CG (Center of Gravity) point varies as the manipulator moves between the three extreme points of its stroke as shown in Fig.9. It is obvious that the most critical extreme position is the starting point in the stroke, at which the CG point approaches most the end line of the platform. So we should enhance stability in the front side. Another source of instability is the torque generated due to wall-roller contact force that will provide quite large reaction torque due to the long span of the manipulator that will reach 2.7 meters at end point of stroke. This tends to turn over the whole robot from backward, where we should enhance the stability. Self stable platform should constitute of three or more wheels. Three wheeled platform can provide stability for three faces at 120 degrees, since at each face there are two wheels carrying the load, but not for opposite faces at 180 degrees. The need for stable front and back will lead us to the choice of four wheeled platform.

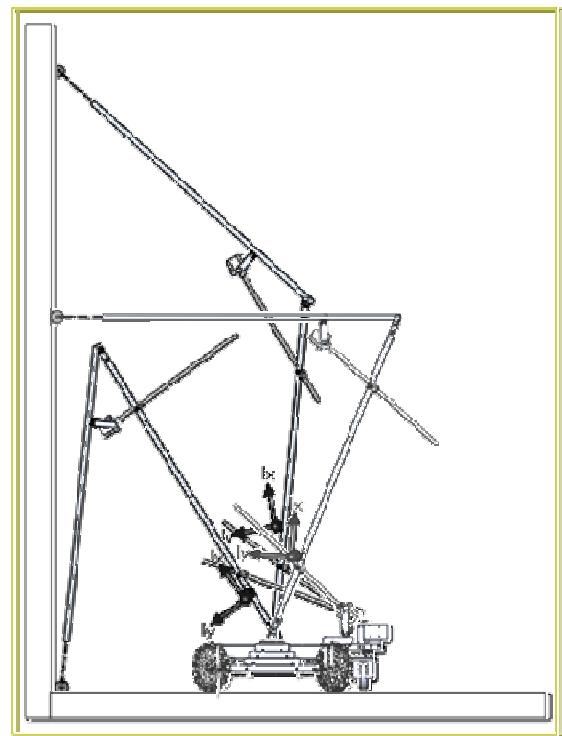

Fig. 9 C.G variation with the three extreme configurations

Robot's platform needs to have three degrees of freedom. It has to move in both the x and y directions in order to approach the wall and move between successive strips of paint. Also it needs to rotate about z axis in order to have the ability to adjust its orientation facing the wall so as to assure parallelism before starting the actual painting.

From this data we can think of two main approaches to enable such degrees of freedom which are:

1. Attaching a motor to each single wheel.
2. Attaching one motor to each pair of wheels and using one idle motor for the idle wheel attachment.

Considering the first solution we should have four motors with four velocity controllers. Advantages of this method include precise control of platform velocity, fast reach of the desired position and orientation and having all three DOF enabled without the need of extra attachments. On the other hand we have four motors to control which introduces extra cost of sophisticated controllers and motors. But even when applying velocity control on motors we can't overcome using ultrasonic sensor signals as a feedback element from the operational space. The other alternative is to attach every two wheels to a single shaft and by doing so we have one motor dedicated to each pair of wheels. This will enable only two degrees of freedom that are moving in x and y directions. And here comes the need for an extra attachment that enables the third degree of freedom, this is simply an idle castor wheel as shown in Fig.10 that is being raised and lowered by a third motor. On lowering this idle wheel, it replaces both back omni wheels in touch with the ground, so the robot can rotate by making the motors spin in similar directions without the fear of hindering from the on-axis wheels which are now floating, Table III summarizes the idea.

TABLE III
 DOF ACHIEVED BY PLATFORM

Idle wheel state	Achieved DOF	DOF
Up	Linear motion in X & Y-axes	2
Down	Rotation about Z-axis	1

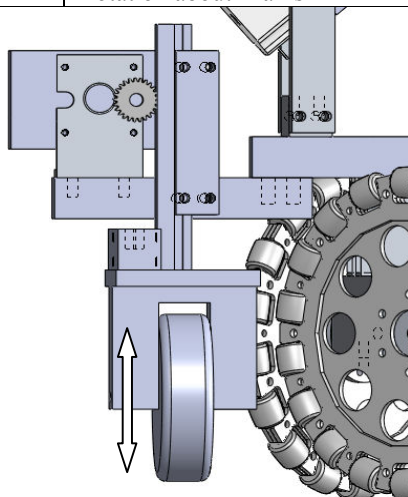

Fig. 10 Idle castor wheel attachment allowed to move up and down as indicated by the arrow

IV. CONTROL ALGORITHM

Automation aims at painting the whole wall without human intervention. Here the algorithm assumes the platform's initial position is in the middle of the room and facing the wall to be painted.

As pointed out in the previous section, platform design have the advantage of being easy to control, having each pair of opposite wheels connected together and given the same direction of rotation by one DC motor. This in fact gives the possibility to control the position and orientation of the platform in an on/off fashion, by getting the feedback of the ultrasonic sensors as shown in Fig.11 which gives out the distance away from the surrounding walls. If both motors are spinning with different velocities, then the platform will move in a straight line that is not parallel, but inclined at some angle to the facing wall, after reaching the desired position we can then adjust the orientation using the idle wheel attachment.

The control algorithm indicated by the flowchart shown in Fig.12 starts by scanning the front side of the platform using two front ultrasonic sensors, then according to the indicated distances it will move forward or backward till one of the sensors indicate the required value of P_x , at this point we have reached our position in x and y directions and still have to adjust the platform's orientation. Here comes the role of the idle wheel attachment, where it moves downward enabling the third degree of freedom about z axis as indicated by the flowchart shown in Fig.13. According to the position of the sensor that has given the exact distance, the direction of rotation will be determined. This step should be repeated such many times until the required accuracy in positioning is fulfilled. After that it scans both sides of the platform in search for the nearest beginning of the facing wall. Then the platform moves toward it until the corresponding side range sensor indicates a clearance value of 5cm, then adjusts its orientation again. At this point the robot is ready to start painting the first strip of the wall with a width of 21 cm. By finishing this strip the platform moves laterally a distance of 20cm (software adjustable), readjust its orientation and start painting the next strip and so on. An overlap of 1cm between every two successive paint segments is required to maintain paint continuity, and this overlap is adjustable based on experiments.

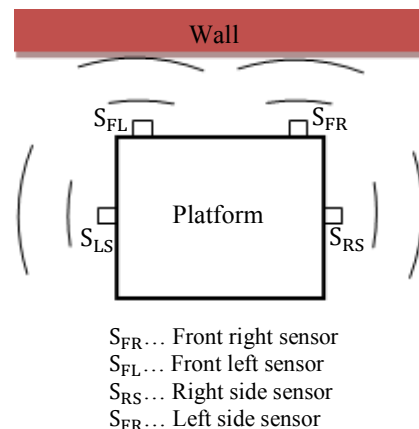

Fig. 11 Schematic representation of ultrasonic sensors as position and orientation feedback devices

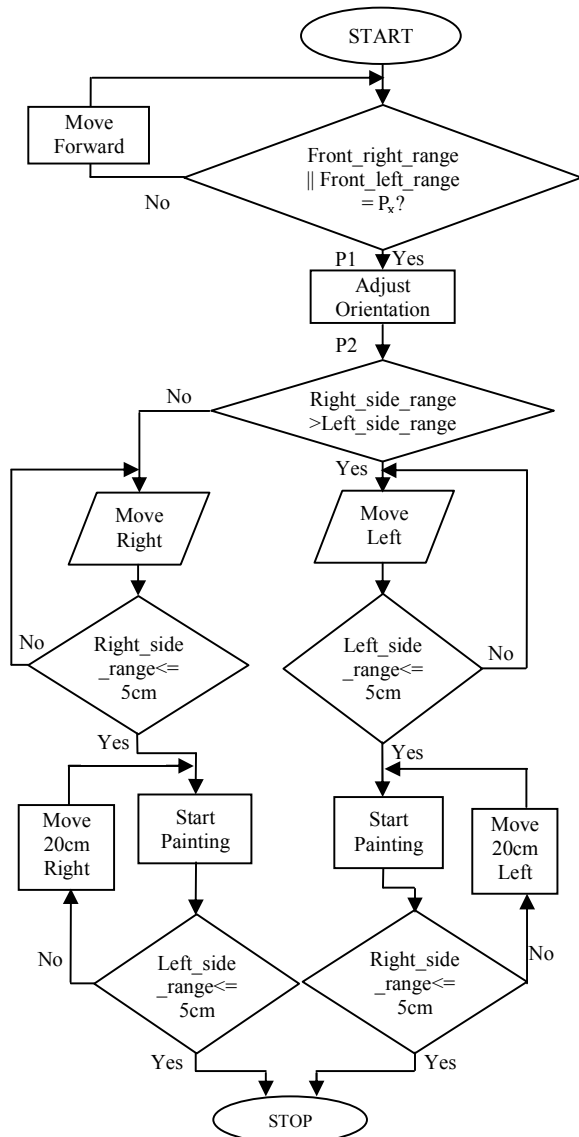

Fig. 12 Flowchart for control algorithm

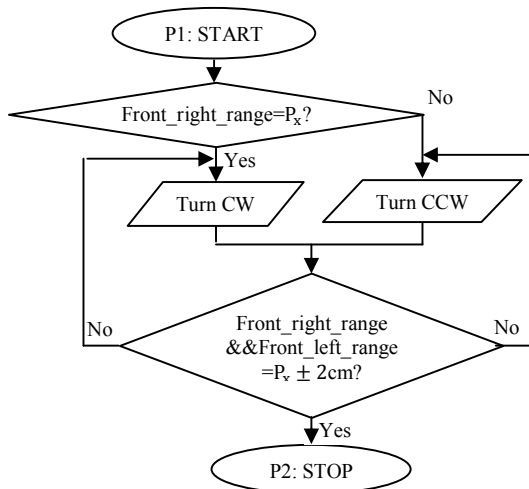

Fig. 13 Flowchart for orientation adjustment

V. IMPLEMENTATION AND EXPERIMENTAL RESULTS

A. The Painting Arm

For the purpose of lowering the overall cost of the robot two stepping motors have been used for driving the joints, controlled by micro-stepping drivers. Since open loop control is utilized, stepper motors have to be over designed during the selection process. From the previous torque curve we realize the maximum torque requirements as 0.15 N.m for first joint actuation and about 0.1 N.m for second joint. Specifications of both selected motors after using a large safety factor are shown in Table IV.

TABLE IV
 JOINT DRIVING MECHANISM SPECIFICATIONS

Item	Description
First joint stepper motor ratings	2.12 Amp/phase, 2 N.m holding torque, 1.8 degree/step.
Second joint stepper motor	2 Amp/phase, 0.65 N.m holding torque, 1.8 degree/step.
Stepper motor size	Nema 23
Micro-stepping driver	50 VDC max. supply voltage, 4.2 A.
Ball nut and screw	16 mm screw diameter, 5mm pitch, 760 Kg.f load rating.

The robotic arm design presented in past sections has been implemented in full scale as shown in Fig.14.

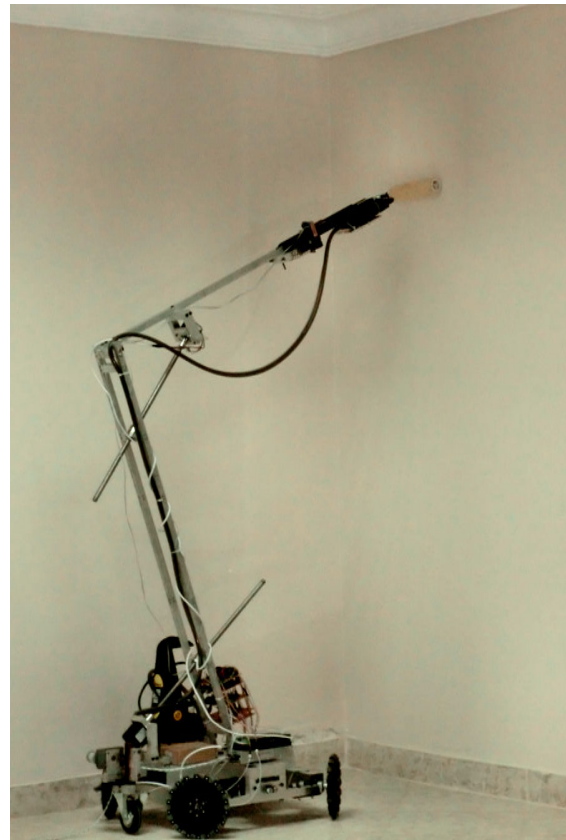

Fig. 14 Photograph of the painting robot

B. Contact-Maintaining Spring Performance

Fig.15 shows the workspace of compensation using the previously mentioned pre-compressed spring together with the measured values of spring compression. It is obvious that there is a large error in compression that is beyond allowable

theoretical values. Two reasons resulting in such error are the shifting between axis of roller and that of link2 and at the beginning of operation the change in thetas is very small, so as the manipulator elevates, the spring extends without any movement in the roller till the balance between the roller weight and the tension force in spring happens. Experimental observations confirm contact presence between roller and wall due to roller weight despite the measured error in permissible compression. If we move above the line of initial compression, the spring extends but decreasing the value of compression till we reach the curve of free length at which the compression in spring equals zero. While moving downwards means that the spring is further compressed.

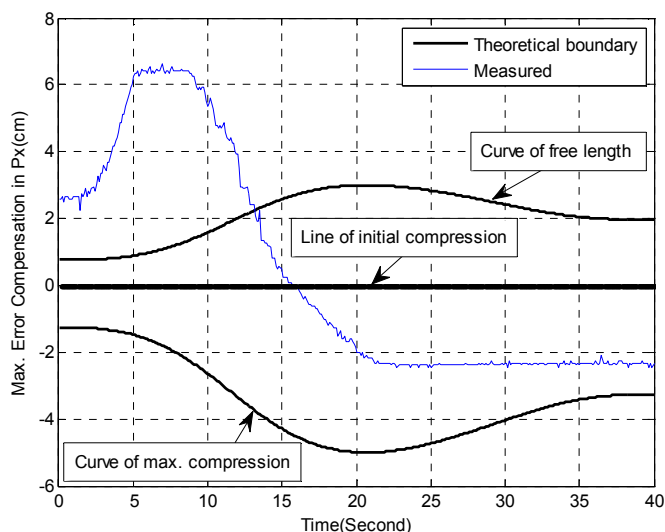

Fig. 15 Maximum error in p_x that can be compensated and the measured spring compression

Fig.16 shows the normal force acting upon the wall by the roller due to the addition of the spring. Both the theoretical and measured values are provided. Theoretical curve assumes perfect control is applied and that no deviation in p_x is encountered so that the initial compression of 3cm is constant throughout the whole trajectory. As shown there is some variation in the contact force range of both curves due to error presence in trajectory; 1.9 to 8 Newton in theoretical and 1.5 to 11.5 in measured. This range of variation is assumed to have little effect on the quality of paint.

C. The Mobile Platform

Three DC geared motors have been used in providing motion to the platform two of them are attached to the two main axes responsible for X-Y positioning, while the third is used by the idle castor wheel attachment and responsible for orientation. Transmission between motors and shaft axes is done via gear-pinion while using rack-pinion in case of idle wheel. Motor specifications are presented in Table V, whereas the full scale implementation is shown in Fig.17.

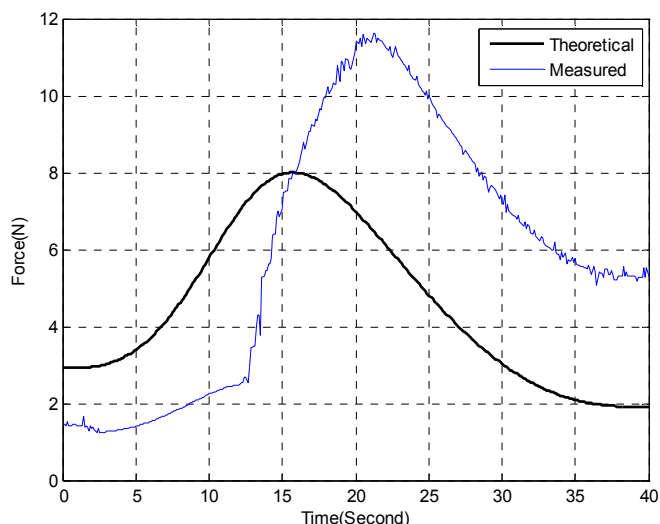

Fig. 16 Normal force applied to the wall during painting in both theoretical and the measured values

TABLE V
 MOBILE PLATFORM SPECIFICATIONS

Item	Description
Size	650 L, 650 W mm
Weight	13 Kg
Motor type	DC brush
Motor rating	12V, 1.5A, 12R.P.M
No. of motors	3
Wheel type	Omni-directional + Castor
No. of wheels	4 + 1

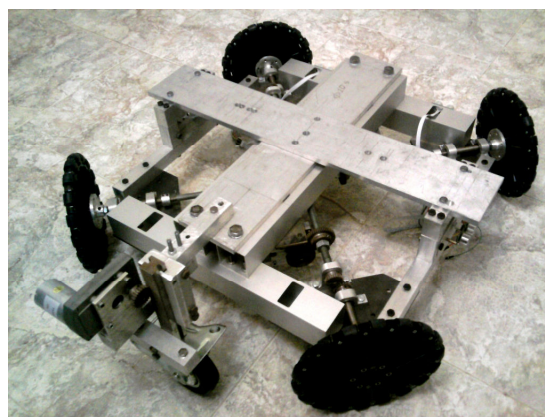

Fig. 17 Photograph of the mobile platform

D. Painting Duration

Experiments have shown an average duration of 0.101 hour/m² for two layers of paint, which means a 10m width wall can be painted in 2.71 hours. This is based on an overlap of 4 cm, meaning that each stroke paints a strip of 17 cm width. Warszawsky [1] and Kahane [2] have concluded a 0.019 hour/m² for two layers duration which is faster by 5.3 times. But their system requires an operator to mark the position of the first work station which is not required in this work. Also the weight of at least 500 kg limits the robot from domestic use. Aris [6] have reported a 0.076 hour/m² duration (without referring to the number of layers), which is faster

than this work by 1.3 times. But again it has the drawback of painting only the ceiling and being large in size.

E. Control Hardware

painting duration of 0.101 hour/m² has been achieved which is sufficient as targeted for domestic use. It is expected that further enhancement of the trajectory can divide this number by two and introduce ceil painting as well.

ACKNOWLEDGMENT

This research activity has been funded by Pharmaceutical Company of Egypt (Pharco) which is gratefully acknowledged.

Arab Organization for Industrialization's Kader factory has significantly participated in manufacturing the mechanical designs and is greatly acknowledged.

REFERENCES

- [1] A. Warszawsky, Y. Rosenfeld: "Robot for interior finishing works in building: feasibility analysis," ASCE Journal of Construction Engineering and Management, vol.120 (1), pp. 132-151, 1994.
- [2] B. Kahane, Y. Rosenfeld: "Balancing human-and-robot integration in building task," Computer-Aided Civil and Infrastructure Engineering, vol.19, pp. 393-410, 2004.
- [3] B. Naticchia, A. Giretti, A. Carbonari. "Set up of an automated multi-color system for interior wall painting," International Journal of Advanced Robotic systems, vol. 4, No. 4 , pp. 407-416, 2007.
- [4] M. De Grassi, B. Naticchia, A. Giretti & A. Carbonari. "Development of an automatic four color spraying device carried by a robot," 24th ISARC, December 17-19, Sendai, Japan, 2007.
- [5] B. Naticchia, A. Giretti, A. Carbonari: "Set up of a robotized system for interior wall painting," Proceedings of the 23rd ISARC, October 3-5, Tokyo, Japan, 2006.
- [6] I. Aris, A. K. Parvez Iqbal, A. R. Ramli & S. Shamsuddin. "Design and development of a programmable painting robot for houses and buildings.," Jurnal Teknologi,Universiti Teknologi Malaysia, vol. 42(A), pp. 27-48, June 2005.
- [7] M. W. Spong, S. Hutchinson, M. Vidyasagar: Robot Modeling And Control. John Wiley & Sons Publishing Inc., 2006, pp. 22-24 and pp. 259-262.
- [8] B. Siciliano, L. Sciavicco, L. Villano, G. Oriolo: "Robotics Modeling, Planning and Control," Springer Publishing Inc., 2010, pp.165-168.

Open Science Index, Mechanical and Mechatronics Engineering Vol:5, No:11, 2011 publications.waset.org/6737/pdf

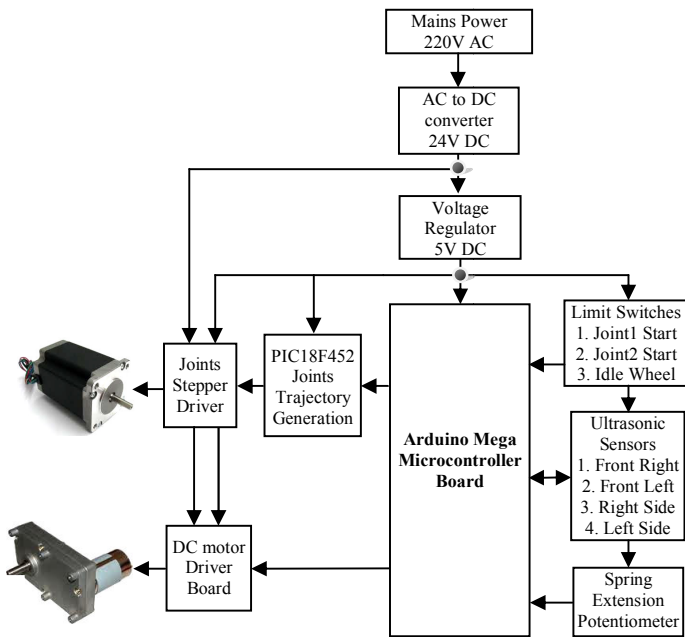

Fig. 18 Control architecture

Fig. 18 shows the control architecture of the robot. Two PIC18F452 microcontroller chips are used as indexers each is responsible for one of the two joints. The required upward velocity trajectory is divided up to 400 distinct points each of which is being supplied to the stepper driver in the form of square wave having a frequency proportional to the required velocity. The output frequency is updated once every 0.1 second making the period of 40 seconds. Then these trajectory points are generated in reversed order constituting the downward velocity trajectory. Arduino Mega microcontroller board is used as the high level controller. It gives high level commands to the PICs to synchronize the operation of the two joints and to the DC motor driver board for platform motion. At the same time it is responsible for all IO from different sensors. The control algorithm shown in Fig.12 and Fig.13 are implemented in this Arduino board.

VI. CONCLUSION

A two link planar robotic arm with new actuating mechanism and a mobile platform were designed and implemented. An algorithm for automating the process of painting a single wall was developed. The implemented mobile platform was tested and succeeded in carrying the intended load while enabling the plane degrees of freedom. The two link manipulator was tested and succeeded in fulfilling the intended reachability, while maintaining low levels of vibration and noise. Overall system have been successfully integrated and tested. The robotic arm has succeeded in moving along the trajectory intended while keeping roller-wall contact at all times. The mobile platform has fulfilled its lateral feeding task in the desirable manner. A