

The Buffer Gas Influence Rate on Absolute Cu Atoms Density with regard to Deposition

S. Sobhanian^A, H. Naghshara^B, N. Sadeghi^C, S. Khorram^B

Abstract—The absolute Cu atoms density in $\text{Cu}(^2\text{S}_{1/2} \leftarrow ^2\text{P}_{1/2})$ ground state has been measured by Resonance Optical Absorption (ROA) technique in a DC magnetron sputtering deposition with argon. We measured these densities under variety of operation conditions: pressure from 0.6 μbar to 14 μbar , input power from 10W to 200W and N_2 mixture from 0% to 100%. For measuring the gas temperature, we used the simulation of N_2 rotational spectra with a special computer code. The absolute number density of Cu atoms decreases with increasing the N_2 percentage of buffer gas at any conditions of this work. But the deposition rate, is not decreased with the same manner. The deposition rate variation is very small and in the limit of quartz balance measuring equipment accuracy. So we conclude that decrease in the absolute number density of Cu atoms in magnetron plasma has not a big effect on deposition rate, because the diffusion of Cu atoms to the chamber volume and deviation of Cu atoms from direct path (towards the substrate) decreases with increasing of N_2 percentage of buffer gas. This is because of the lower mass of N_2 atoms compared to the argon ones.

Keywords—Deposition rate, Resonance Optical Absorption, Sputtering.

I. INTRODUCTION

IN a DC magnetron deposition system, we have measured the absolute Cu atoms density in the $\text{Cu}(^2\text{S}_{1/2} \leftarrow ^2\text{P}_{1/2})$ ground state. We have used the Resonance Optical Absorption (ROA) technique using a commercial hollow cathode lamp as light source. The operating conditions were 0.6 - 14 μbar gas pressure and 10 - 200 W magnetron discharge power. The deposition rate of copper in a substrate positioned at 18 cm from the target was also measured with a quartz microbalance. The gas temperature, in the range of 300 to 380 K, was calculated from the emission spectral profile of $N_2(\text{C}^3\Pi_u - \text{B}^3\Pi_g)$ 0-0 band at 337 nm [1]. The isotope-shifts and hyperfine structures of electronic states of Cu, [2] and the exact Beer-Lambert equation have been taken into account [3]. There are no estimations in our calculating treatments, so we could find reliable values of absolute number density of Cu atoms in the plasma. The other techniques cannot give the absolute number density with so accuracy than, and we can compare the deposition rate and Cu atoms number to find the relation between the parameters. Cu atoms density decreases as a factor of 4 for 0.6 μbar and a factor of 2 for 14 μbar with

increasing of N_2 percentage from 0% to 100% in the gas mixture. But the deposition rate fluctuates about 0.1 $\text{A}^\circ/\text{sec}$ around the measured value for a constant applied power and pressure. So we could say that the decreasing of Cu atoms density has not a big influence on deposition rate. It could be assumed that Cu atoms diffusion form the direct path towards the chamber walls decreases. This is similar to the influence of decreasing of gas pressure. We attribute this effect to the mass of buffer gas atoms and molecules. With this result we could find the best mixture of buffer gas for lower diffusion of sputtered atoms to the vacuum chamber volume for any target. In section II,

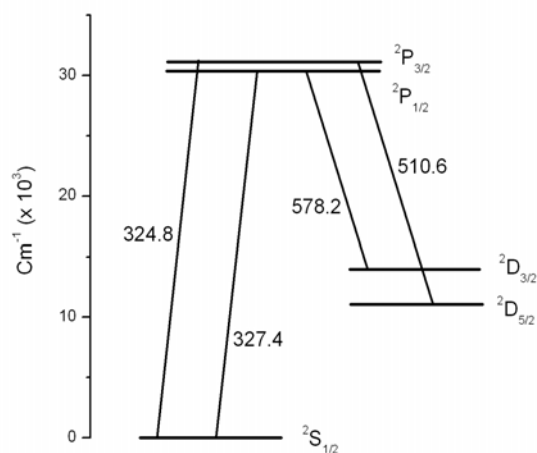

Fig. 1 Energy levels of Cu atom

we give the experimental device and methods used in our study In section III, some experimental results will be given and finally a brief conclusion will be presented in section IV.

II. EXPERIMENTAL DEVICE

The experimental device used in this study is a MECA-2000 co-sputtering (DC & RF) magnetron plasma unit shown schematically in figure (2). It consists of stainless-steel cylindrical chamber of 60 Cm diameter and 50 Cm height. A 7 Cm, circular 99% copper target disc is retained by a simple clamp for quick and easy change [4]. Planar magnetron 330 sputter source is DC and RF compatible and hence may be used to sputter either electrically conducting target materials (DC or RF) or electrically non-conducting material (RF power only). The chamber is evacuated by a 2033 Alcatel

rotary pump and ATP-900 Alcatel turbo molecular pump down to a pressure of about 5×10^{-5} mbar .

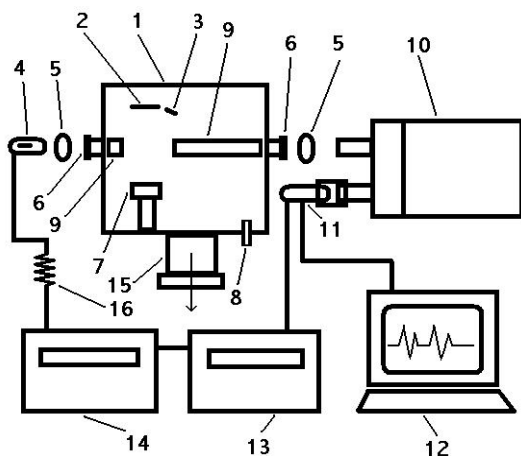

Fig. 2 Experimental setup Experimental Setup: 1 chamber, 2 Substrate, 3: Quartz balance, 4: HC Lamp, 5: Lens, 6: Quartz window, 7: Target, 8: Gas inlet, 9: Limiting tubes, 10: Monochromator, 11: PMT, 12: Computer, 13: Pulse generator, 14: Power supplier of the lamp, 15: Pumping orifice, 16: ballast resistor of HCL.

The argon (with 99.999% purity) with a pressure of 0.3 to 14 microbar is used for plasma productions. The plasma is produced by applying a negative high voltage to the target, while the grounded chamber walls acting as anode. The chamber is provided with some viewing ports, two of them each with 2.5 cm diameter quartz windows are placed along a diagonal opposite to each other. The axis of these windows is positioned at 10 cm above the target where the plasma is almost homogenous. The distance from the target to chamber base is 12 cm and a 10 cm diameter substrate holder is located at the same radial position as the target and 18 cm above it. The deposition rate of sputtered metal atoms (Cu) is measured by a quartz microbalance. The density of copper atoms is measured by resonance absorption technique with the probe beam from a copper hollow cathode lamp. As it is clear, the determination of absorbing atoms density requires the knowledge of Doppler width of the absorption line, hence, the kinetic temperature of these atoms [6]. A very reliable method to obtain the gas temperature is from the line width of the Doppler-broadened absorption profile of a specific line. Here we deduce the temperature from the emission intensity of the rotational lines of $N_2(C^3\Pi_u - B^3\Pi_g)$ transition [1]. So different percent of nitrogen is added to the argon feed gas and 337nm line is recorded with the optical detection system. For the resonance absorption measurements a 2.5 cm diameter, 10 cm focal length quartz lens produces a parallel light beam from a commercial copper hollow cathode lamp (HCL). After passing through the plasma chamber, the beam is focused with a 2.5 cm diameter, 5 cm focal length quartz lens into the entrance slit of a HR-320 monochromator (Jobin-Yvon). This optical system provides a spectral resolution of about 0.14nm. The light is then detected with a photomultiplier tube

(Electron tube limited model P25232-05). For absorption measurements, the monochromator is set on one of the copper lines (324.7, 327.4 or 510.6 nm). To extract the absorption signal from the light received by the PMT, the emission of hollow cathode lamp is modulated with a 10 Hz square wave, by modulation of the voltage applied to the lamp with a MOSFET relay in its power supply.

III. RESULTS

The number densities of $Cu(^2S_{1/2} \leftarrow ^2P_{1/2})$ ground state atoms are measured by previously mentioned resonance absorption technique.

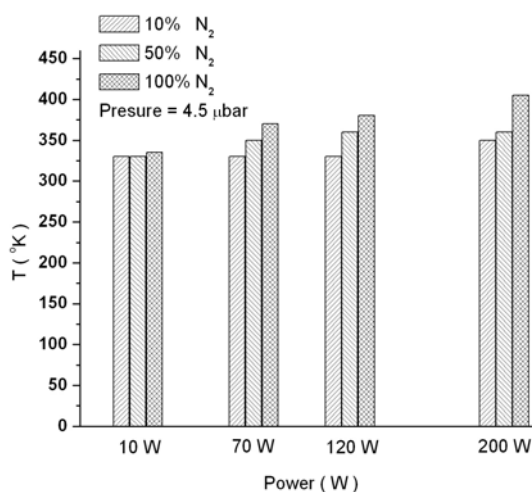

Fig.3 Gas temperatures

For the gas temperature measurements we use N_2 rotational temperature [5]. We used the $N_2(C^3\Pi_u - B^3\Pi_g)$ 0-0 band at 337 nm. In figure 3 the measured gas temperatures are plotted for different powers and different mixture percentage.

We used these values to calculate the density of Cu atoms. The HCL lamp temperature assumed to be 450°K [7].

The number densities are affected by the amount of the N_2 admixture. In figure 4, we give the results of measurements of $Cu(^2S_{1/2} \leftarrow ^2P_{1/2})$ ground state for different percentages of N_2 and input power and for three pressures of 4.5 microbar.

As shown in this figure, the increasing of N_2 percentage with respect to argon in the gas mixture decreases the absolute density of Cu atoms.

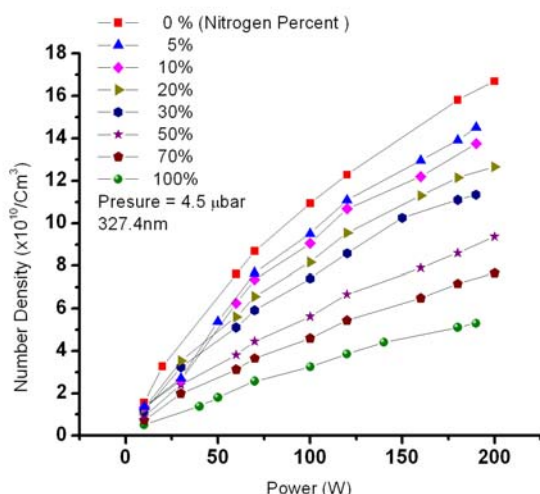

Fig. 4 $\text{Cu}(^2\text{S}_{1/2} \leftarrow ^2\text{P}_{1/2})$ atoms density for $4.5\mu\text{bar}$

In figure 4 one can see that for 4.5 microbar this decrease in density is about a factor of 3.

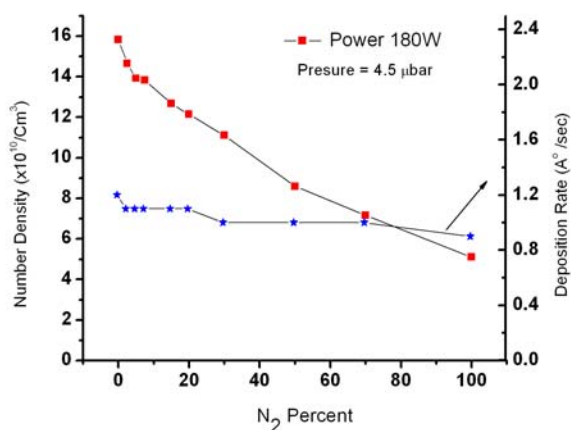

Fig. 5 $\text{Cu}(^2\text{S}_{1/2} \leftarrow ^2\text{P}_{1/2})$ ground state density for $4.5\mu\text{bar}$ at 180W

A rough displaying of these results is plotted in figures 5. In this figure we can see this effect for a constant power.

IV. CONCLUSION

The absolute number density of Cu atoms decreases with increasing of N_2 percentage of buffer gas at any conditions of this work. But the deposition rate, is not decreased with the same manner. The deposition rate variation is very small and in the limit of measuring equipment accuracy. So we could say that the decreasing of Cu atoms density has not a valuable influence on the deposition rate. The mass of N_2 molecules is less than the argon atoms. This leads to decreasing of Cu atoms number density in plasma in a constant power. We can see this effect from our experiments in figure 5, but this

decreasing of atoms does not lead to a decrease in the deposition rate. It can be assumed that the Cu atoms diffusion from the direct path decreases. This is similar to the influence of decreasing of gas pressure. We attribute this effect to the mass difference of buffer and admixture gases atoms and molecules. With this result one can find the best mixture of buffer gas to have lower diffusion of sputtered atoms to the vacuum chamber volume for any target. So the buffer gas mixture has a great role in controlling the magnetron sputtering depositions.

ACKNOWLEDGMENT

Authors would like to thank Ing F. Hadian for his expert advices in the use of the magnetron sputtering equipment.

REFERENCES

- [1] Lin Xu, N. Sadeghi and et.al., J. of Appl. Phys. 101, 013304 (2007).
- [2] J. Tenenbaum and et.al., Optics Com. 32, 473 (1980).
- [3] A.C.G. Mitchell, M. W. Zemansky, 1971, "Resonance Radiation and Excited Atoms", Cambridge University Press, London.
- [4] S. Konstantinids and et.al., J. of Appl. Phys. 95, 2900 (2004).
- [5] E. Eslami and N. Sadeghi, J. of Appl. Phys. 43, 93-102 (2008).
- [6] P. Baltayan, F. Hartmann, I. Hikmet and N. Sadeghi, J. of Chem. Phys. 97, 5417 (1992).
- [7] H. Naghshara, S. Sobhanian, S. Khorram and N. Sadeghi. Phys. D: Appl. Phys. 43, (2010) under publication.