

# A Particle Swarm Optimal Control Method for DC Motor by Considering Energy Consumption

Yingjie Zhang, Ming Li, Ying Zhang, Jing Zhang, Zuolei Hu

**Abstract**—In the actual start-up process of DC motors, the DC drive system often faces a conflict between energy consumption and acceleration performance. To resolve the conflict, this paper proposes a comprehensive performance index that energy consumption index is added on the basis of classical control performance index in the DC motor starting process. Taking the comprehensive performance index as the cost function, particle swarm optimization algorithm is designed to optimize the comprehensive performance. Then it conducts simulations on the optimization of the comprehensive performance of the DC motor on condition that the weight coefficient of the energy consumption index should be properly designed. The simulation results show that as the weight of energy consumption increased, the energy efficiency was significantly improved at the expense of a slight sacrifice of fastness indicators with the comprehensive performance index method. The energy efficiency was increased from 63.18% to 68.48% and the response time reduced from 0.2875s to 0.1736s simultaneously compared with traditional proportion integrals differential controller in energy saving.

**Keywords**—Comprehensive performance index, energy consumption, acceleration performance, particle swarm optimal control.

## I. INTRODUCTION

ENERGY, the material basis of human social activities, has been exploited so much that its inevitable exhaustion has become a serious problem for human society, and has even threatened the sustainability and strategic safety of all countries in the world. The issue of energy saving has received considerable critical attention. The DC drive system is often seen in the field of fine controls such as machines, large mining equipment, and trolleybus, for its good starting and braking performance, simple structure, and ease in controlling speed, etc. However, in the process of starting and accelerating, the energy consumption of the DC motor is high and the energy conversion efficiency is low. In the course of machine operation, energy-saving measures and control technology are closely linked, as the energy-saving measures require innovative control technologies. The classical control theory uses the rapidity, stability and accuracy of the response,

dynamic as well as static, to measure the controller performance, but too little work has been devoted to take the energy-saving as an index to measure the controller performance. A number of researchers have reported energy-saving control method about DC motor [1]-[5]. Optimal control and minimum energy consumption control are prominent achievements in energy conservation control theory. The problem of the control law of minimum energy consumption is to find out what kind of control law can make the energy consumed in this working process be minimized under a given trip and specified time. Ren studies that the trajectory of the optimal control quantity of energy consumption is deduced based on the model of DC drive system. Compared with the control algorithm aiming at the fastest response, the control algorithm aiming at the optimal energy consumption can make the DC drive system save more energy [1], [2]. Hu studies the minimum energy consumption control of the dynamic system, and respectively discusses the minimum energy consumption control theory of the linear time-varying system, the linear time-invariant system, the terminal time-varying system and the state equation without state variables at the right end [3]. The energy consumption of DC electric drive system for rolling steel is calculated and the energy saving performance is outstanding. However the inductance of the motor on energy saving is not considered in the research. Since the inductance loss is part of energy consumption, there is still a certain gap between the minimum energy consumption calculated in the above research and engineering practice. In [4], it is demonstrated that the optimal control energy consumption considering armature inductance is closer to the actual energy consumption. In [5], the relationship between the minimum energy consumption control and the response rapidity index of classical control system is studied for the start-up process of DC transmission system. Reference [6] takes the square of the control quantity as part of the objective function to solve the optimal energy consumption control problem of linear or non-linear systems in some circumstances. In [7], [8], the energy consumption minimization problem is transformed into a geometric optimization problem; it testifies the convergence ability of the original problem or the sub-problem, and obtains the numerical solution on the computer with the help of the iteration method. The maximum principle proposed by Pontryagin is widely used in the control of minimum energy consumption [9]-[12]. In [13], two adaptive control systems for efficiency-optimized speed control are proposed on the basis of model reference adaptive control system theory. And efficiency is considerably improved by these two methods at a

This work was supported by the Chinesisch-Deutsches Zentrum of NSFC(GZ1445), National Natural Science Foundation of China (51674113), Natural Science Foundation of Hunan Province (2017JJ4003), and Hunan Provincial Innovation Foundation for Postgraduate (CX2017B103).

Y. Zhang\*, M. Li, Y. Zhang and Z. Hu are with the College of Information Science and Engineering, Institute of Industry Energy-Saving Control and Evaluation, Hunan University, Changsha 410082, China (\*Corresponding author, e-mail: zhangyj@hnu.edu.cn; minglee@hnu.edu.cn; zhangying14@hnu.edu.cn; huzuolei@hnu.edu.cn).

J. Zhang is with the Institute of Electrical and Information Engineering, Hunan University, Changsha 410082, China (e-mail: zhangj@hnu.edu.cn)

light load condition. Torque ripple is one of the reasons that affect the low efficiency of the motor. Direct torque optimization control is used to reduce the content of torque harmonics based on the inner loop feedback current, thereby achieving higher energy efficiency [14]. In [15], [16], a triac-based drive with an optimal efficiency voltage controller is proposed. And the double-revolving-field concept is employed in the theoretical analysis and a relation between the main and auxiliary stator currents is derived that accomplishes optimal efficiency under constant torque operation. Taheri et al. proposed an adaptive flux search control technique to deal with the efficiency optimization of field oriented control by proper change of flux variation steps and increases accuracy of the Search Control (SC) technique based on a proper loss model [17]. Ali et al. put forward the application of AI technology to optimize the Proportion Integration (PI) controller of flux oriented control to improve the response and performance of the motor. Thus, the energy consumption efficiency can be improved by reducing the input electric energy of the motor [18]. In terms of the application research of energy saving control, researchers mainly focus on the induction motor that is frequently started, industrial objects with high energy consumption, such as industrial kilns [19], and energy-limited ones, such as electric vehicles [20], [21], wall-climbing robots [22], and underwater operating robots [23]. However, the above research does not explicitly put forward energy consumption as one of the target function indicators. It has been suggested that a comprehensive performance index in which the energy consumption is definitely regarded as one of the indexes should be established, and the energy consumption and response time are optimized by flexibly setting the energy consumption weight. In this study, energy saving and traditional control performance are considered comprehensively.

The rest of the paper is organized as follows. In Section II, the model of the wound-field DC motor is built. In addition, the conflict between energy consumption and acceleration performance of the motor drive system are analyzed in detail. In Section III, comprehensive performance index of DC motor control system considering energy consumption is proposed. In Section IV, control scheme for energy-saving optimization is designed. In Section V, experiments about energy consumption and acceleration performance designed and results are analyzed. The conclusions of the paper are summarized in Section VI.

## II. MODELING OF WOUND-FIELD DC MOTOR

In this section, the wound-field DC motor will be modeled. The stator of a wound-field DC motor is composed of an iron core and an excitation winding. When connecting the power supply, the current passes through the stator excitation winding and a number of pairs of magnetic poles are established between the iron cores to form a magnetic field. The field windings and armature windings are in series connection. The equivalent circuit diagram of wound-field DC motor is shown in Fig. 1.

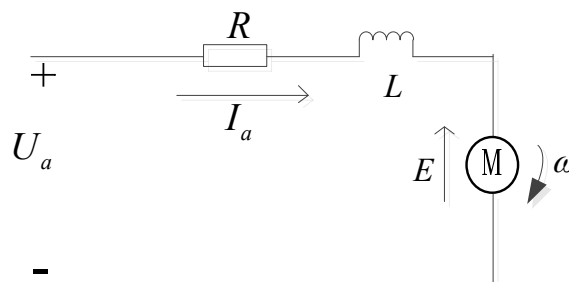

Fig. 1 Equivalent circuit diagram of the wound-field DC motor

According to the Kirchhoff's second law (KVL), the equation of the motor voltage circuit is

$$U_a = I_a R + E + L \frac{dI_a}{dt} \quad (1)$$

where  $U_a$  represents the input voltage for the motor,  $I_a$  the armature current for the motor,  $R$  the total resistance for armature circuit,  $L$  the inductance of the motor,  $E$  the back EMF of the motor, and  $\omega$  is the angular speed of the motor.

The linear quadratic (LQ) control, a widely used method in engineering, is an optimal control problem which takes the linear system as the control object, with the LQ function as the optimal objective. While the main energy consumption of the system cannot be represented by the control quantity in the objective function, it is necessary for the DC motor, the energy consumption object, to establish a state equation. The dynamic equation of the motor is as follows:

$$\begin{cases} T_a - T_l = J \frac{d\omega}{dt} \\ T_a = C_T \phi I_a \\ \omega = \frac{d\alpha}{dt} \end{cases} \quad (2)$$

where  $T_a$  represents the DC motor armature torque,  $T_l$  DC motor load torque,  $J$  motor inertia,  $\omega$  motor angular speed,  $C_T$  motor torque constant,  $\phi$  excitation flux,  $I_a$  DC motor armature current, and  $\alpha$  DC motor's initial angular position.

If the state variable is assumed,  $X_1 = \alpha$ ,  $X_2 = \omega$ , then (2) can be expressed as state equation (3):

$$\begin{cases} \dot{X}_1 = \omega \\ \dot{X}_2 = \frac{C_T \phi}{J} I_a \end{cases} \quad (3)$$

The general equations of linear time-invariant systems are:

$$\begin{cases} \dot{X}(t) = AX(t) + Bu(t) \\ X(t_0) = X(0) \end{cases} \quad (4)$$

The initial state  $X(0)$  satisfies the equation  $X_1(0) = \alpha_0$ ,  $X_2(0)$

= 0.

Formula (3) is represented by a linear time-invariant system as:

$$\begin{bmatrix} \dot{X}_1 \\ \dot{X}_2 \end{bmatrix} = \begin{bmatrix} 0 & 1 \\ 0 & 0 \end{bmatrix} \begin{bmatrix} X_1 \\ X_2 \end{bmatrix} + \begin{bmatrix} 0 \\ \frac{C_T \phi}{J} \end{bmatrix} u(t) \quad (5)$$

The energy consumption of the motor consists of several parts, such as the copper loss  $P_{Cu}$ , the iron loss  $P_{Fe}$ , the mechanical loss  $P_m$ , and the additional loss  $P_c$ , etc. The copper and iron consumption account for 80% of the total energy consumption loss in the DC drive system [24]. The copper consumption is the major loss of the motor when the armature current exceeds the rated value in the acceleration dynamic process. Taking the copper loss as an approximation of the total energy consumption to solve the minimum energy consumption problem, the optimization problem of the motor's energy consumption is transformed into the minimum problem under certain constraints. The copper loss of the motor is

$$J_q = \int_0^{\tau_i} u^2(t) dt \quad (6)$$

where  $u$  represents the armature current of the DC motor, that is, the control signal, and  $\tau_i$  the settling time.

When the terminal time is fixed, the optimal solution satisfying (6) is

$$u^*(\tau_i) = -B^T e^{-A^T \tau_i} \left( \int_0^{\tau_i} e^{-A \tau} B B^T e^{-A^T \tau} dt \right)^{-1} X(0) \quad (7)$$

When the terminal time is a variable, assuming  $\tau_{i1} < \tau_{i2}$ , the optimal solutions are  $u^*(\tau_{i1})$  and  $u^*(\tau_{i2})$  respectively, and the corresponding optimal energy consumption are  $\int_0^{\tau_{i1}} [u^*(\tau_{i1})]^2 dt$  and  $\int_0^{\tau_{i2}} [u^*(\tau_{i2})]^2 dt$  respectively, then:

$$\int_0^{\tau_{i1}} [u^*(\tau_{i1})]^2 dt > \int_0^{\tau_{i2}} [u^*(\tau_{i2})]^2 dt \quad (8)$$

According to (8), there is a conflict between the energy consumption and the response time of the motor in the start-up process, that is, an appropriate increase of the response time is beneficial to energy conservation. It would be a slow response if we only aim at reducing of energy consumption for this control scheme. However, only considering the fast response index of the system will make the energy consumption too large to meet the requirements of energy saving.

### III. COMPREHENSIVE INDEX OF THE CONTROL PERFORMANCE

The traditional evaluation indexes of the control system mainly consider the dynamic and static performance of the system, including response rapidity, stability and accuracy. And the classical response curve of the control system is

shown in Fig. 2. In this paper, the acceleration process of motor is studied, and we only focus on the dynamic performance. That is to say, we study the problem during the period from the starting point to  $t_s$  in Fig. 2.

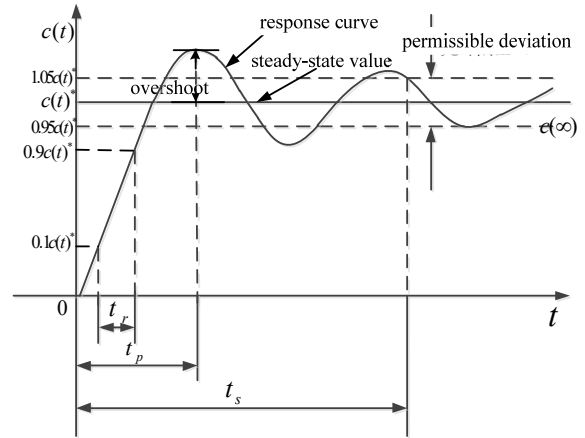

Fig. 2 Classical response curve of the control system

In Fig. 2,  $t_s$  is the setting time, which the response curve from zero to the range of 95%-105% of the steady-state value, and the response value no longer exceeds the range. To maintain the stability of the control system, the integral value of the absolute error of the control system is taken as the objective function to evaluate the stability of the control system, that is, the performance evaluation index of the absolute deviation integral  $f_1(x)$ , shown in (9), is the objective function.

$$f_1(x) = \int_0^{t_s} |e(t)| dt \quad (9)$$

If the value of  $f_1(x)$  is constantly changing, it means that the control system is always in dynamic adjustment, and the control system is unstable; if the value of  $f_1(x)$  is no longer increasing, it means that the control system is stable.

The rapidity of the control system is evaluated by the setting time, and the rapidity index expressed by  $f_2(x)$  as in (10):

$$f_2(x) = t_s \quad (10)$$

The energy consumption performance of the motor is the ratio of the mechanical power output on the motor shaft and the electrical power input from the power supply to the motor. Under a constant load condition, within the time from the start-up acceleration to the stabilized running, the output mechanical energy of the motor can be as follows

$$W_{out} = \int_0^{t_s} (T_L \times \omega) dt \quad (10)$$

The electric power from the external source to the motor is

$$W_{in} = \int_0^{t_s} (U_a I_a + U_f I_f) dt \quad (12)$$

where  $U_a$  represents the motor input voltage,  $I_a$  motor armature current,  $U_f$  excitation voltage, and  $I_f$  excitation current.

The efficiency of the motor from the start-up to the steady-state is:

$$\eta = \frac{W_{out}}{W_{in}} \quad (13)$$

where  $\eta$  represents the efficiency,  $W_{in}$  the total energy input of the motor including the power input of the armature circuit of the motor and the power input of the excitation circuit of the motor, and  $W_{out}$ , the mechanical power output of the motor.

In this paper, the energy-saving optimization control of the transmission control system is studied, taking into account the energy consumption performance evaluation index and the traditional performance evaluation index of the drive control system, so as to achieve the goal of optimizing the energy consumption performance and control performance. In the optimization algorithm which takes into account the energy consumption performance of the motor, the smaller the value of the performance index, the better the control performance. The higher the efficiency of the motor, the less energy consumption. Therefore, the efficiency of the motor is taken as

the energy consumption performance index.

$$f_3(x) = \frac{1}{\eta} \quad (14)$$

Therefore, the integrated control performance index of the DC motor is (15):

$$F(x) = \omega_1 f_1(x) + \omega_2 f_2(x) + \omega_3 f_3(x) \quad (15)$$

In (15),  $\omega_1, \omega_2$  and  $\omega_3$  are the weights of stability, rapidity and energy consumption performance index respectively. And the sum of the weight coefficients is 1.

According to the quantity level of performance indexes values, we set a normalization factor for each performance indicator, as shown in Table I.

Performance index	$f_1(x)$	$f_2(x)$	$f_3(x)$
Normalization factor	$10^{-1}$	$10^1$	$10^0$

#### IV. CONTROL SCHEME FOR ENERGY-SAVING OPTIMIZATION

According to the analysis of Section II, the structure diagram of the DC motor control system is established, using MATLAB, as shown in Fig. 3.

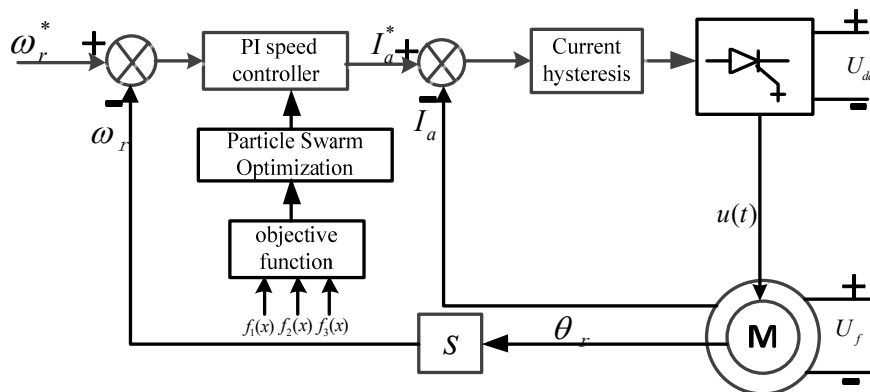

Fig. 3 Structure diagram of the DC motor control system

In Fig. 3,  $\omega_r^*$  represents the reference speed,  $\omega_r$  the feedback speed,  $I_a^*$  the reference value of the armature current,  $I_a$  the feedback voltage of armature current and  $\theta_r$  the rotor position, obtained by differential method.  $U_{dc}$ , DC driving voltage of thyristor, is 280V, and  $U_f$  represents the excitation voltage of the DC motor, and  $u(t)$  represents the control signal, that is, the DC motor current.

Based on the traditional motor control method, the scheme of energy-saving optimization system takes into account both the dynamic and static performance of the response of the traditional control system and the energy consumption performance index in the process of starting and accelerating the motor. The optimal control scheme of the comprehensive performance index is obtained by tuning the parameters of the

speed PI controller.

The PI controller is adopted in the speed control system of DC motor. In Fig. 3, the speed controller is the PI controller, and the parameters are obtained by PSO optimization algorithm. Formula (2) shows that the motor speed is related to the armature current. The armature current is obtained by the motor speed controller. The armature current flows through the current hysteresis loop to the integrated gate turn-off thyristor to obtain the control quantity of the DC motor.

In the system simulation experiment, PSO optimization algorithm is compiled by M file. The comprehensive performance evaluation index of the DC motor is taken as the objective evaluation function of the individual fitness value of PSO algorithm. Through the iterative optimization process of

PSO algorithm, the solution of minimum individual fitness value in the optimization range of parameters of PI controller can be obtained.

In the DC motor control system, the objective optimal scheme is obtained by optimizing the parameters of the speed controller by PSO. The objective function is formulated as (15), and it includes system response speed, stability and energy consumption performance. The speed controller is a PI controller which is optimized by PSO according to the objective function. Firstly, the parameters  $K_p$  and  $K_i$  of the model controller are calculated iteratively, and the parameters corresponding to the optimal fitness of the objective function are obtained. The optimal parameters are brought into the model to obtain the optimized efficiency, response time, overshoot and steady-state error. The classical particle swarm optimization calculation is referred to in [25], which will not be introduced in this paper. For the acceleration process of DC motor, the flow chart of the optimization algorithm of the comprehensive performance index considering energy consumption is shown in Table II.

TABLE II  
THE FLOWCHART OF PSO

1: start
2: Particle swarm initialization
3: Updating $K_p$ and $K_i$ values through velocity and position equations
4: Restricting particle renewal speed and optimization range
5: Computing the fitness of current particle, individual optimal particle and global optimal particle
6: Individual Optimal Particle and Global Optimal Particle Renewal
7: Decision on whether the objective function is the smallest or not
8: Satisfaction ends, otherwise jumping to step 2
9: The optimal $K_p$ and $K_i$ values are brought into the speed controller to calculate the efficiency, steady-state time and overshoot.

## V. EXPERIMENTAL RESULTS AND DISCUSSION

In order to verify the effectiveness of the energy saving optimization control scheme proposed in this paper, the following experiments are designed.

In this paper, experiments are carried out on a CPU computing device with a main frequency of 3.6 GHz and a memory of 16 GB. The simulation model and experiment are carried out by using MATLAB simulation software. Simulink system simulation platform in MATLAB is a working platform which provides system modeling, dynamic simulation and comprehensive analysis. In the process of dynamic simulation of the Simulink control system, the data in the workspace of MATLAB can be invoked, and the results of the dynamic simulation process can also be output to the workspace for other files to use. In the system simulation experiment, the dynamic simulation model of the drive control system in Simulink can be used to output the data into the workspace to simplify the coding. In this paper, MATLAB 9.0 is used to simulate the energy-saving optimization of the transmission control system.

The parameters for the DC motor are given in Table III.

In the particle swarm optimization, the size of particle swarm is 10 and the number of iterations is 30. The

optimization ranges of  $K_p$  is [1.0,50] and  $K_i$  is [1.0,20] respectively. The inertia factor is 0.6, and the acceleration factor is 2.0.

TABLE III  
PARAMETERS OF DC MOTOR

$R_a(\Omega)$	$R_f(\Omega)$	$L_f(H)$	$L_a(H)$	$L_{af}(H)$	$J(kgm^2)$
0.5	240	120	0.01	1.23	0.05

$R_a$  the armature resistance,  $R_f$  the excitation coil resistance,  $L_f$  the excitation coil inductance,  $L_a$  the armature inductance,  $L_{af}$  the mutual inductance between armature and excitation coil, and  $J$  is the moment of inertia.

TABLE IV  
COMPREHENSIVE PERFORMANCE COMPARISON EXPERIMENT CONSIDERING ENERGY CONSUMPTION

$\omega_1$	$\omega_2$	$\omega_3$	$K_p$	$K_i$	$t_s$	$\eta$ (%)	Energy Consumption (W)
0.10	0.10	0.80	1.0000	1.6954	0.1736	68.48	196
0.10	0.15	0.75	1.0000	1.7144	0.1369	68.46	195
0.10	0.20	0.70	1.3401	2.3054	0.1052	64.39	224
0.10	0.25	0.65	1.4189	2.4949	0.0994	63.46	231
0.10	0.30	0.60	1.5466	2.7185	0.0922	62.12	241
0.10	0.35	0.55	1.8399	3.2174	0.0798	59.46	265
0.10	0.40	0.50	2.0820	3.5324	0.0726	57.46	284
0.10	0.45	0.45	3.6519	2.1954	0.0438	49.34	273
0.10	0.50	0.40	4.0805	1.9669	0.0461	49.96	395
0.10	0.55	0.35	3.7020	2.2924	0.0416	48.48	382
0.10	0.60	0.30	3.7185	2.3130	0.0417	48.51	383
0.10	0.65	0.25	3.7129	2.4919	0.0417	48.51	383
0.10	0.70	0.20	3.8498	2.3341	0.0400	47.25	402
0.10	0.75	0.15	3.8860	2.3534	0.0380	45.26	419
0.10	0.80	0.10	3.8692	1.0000	0.0379	45.13	415

The relationship between energy consumption performance and rapidity is studied in this part, so that the weight of rapidity index and energy consumption performance index can be changed to meet the requirements,  $\omega_1 + \omega_2 + \omega_3 = 1$  and  $\omega_1 = 0.1$ . In this experiment, the weight of energy consumption performance index is gradually decreased, while the weight of rapidity index is gradually increased. For each set of weight data, an optimization experiment is conducted according to the algorithm flow of Table II, and 15 sets of data are obtained, as shown in Table IV.

In Table IV, rapidity index and energy consumption performance index are presented respectively in the dynamic acceleration process of the DC motor with the method of comprehensive performance index. And the optimal controller parameters are obtained by PSO.

In order to analyze the data in Table IV more intuitively, the weight of energy consumption performance index and energy efficiency in Table IV are extracted as in Fig. 4.

As can be seen from Fig. 4, with the increase of the weight coefficient of energy consumption performance index, the motor efficiency increases from 45.13% to 68.48% gradually. When the weight coefficient of energy consumption performance index is a minimum of 0.1, the efficiency of the motor is the smallest of 45.13%. When the weight of energy consumption performance index is the largest of 0.8, the efficiency of the motor is the largest of 68.48% and the energy

consumption is  $196W$ . The large increase in energy efficiency observed on Fig. 4 is due to the energy consumption reduced which can be seen in Table IV. While the energy efficiency obtained by the traditional Proportion Integration Differentiation (PID) controller is 63.18% and the energy consumption is  $367W$ . It can be concluded that when the weight of energy consumption performance index exceeds 0.65, the method considering energy consumption achieves higher energy efficiency than the traditional method without energy consumption. Comparing with the traditional PID controller, the proposed method considering the energy consumption increases the energy efficiency by 8.39% and the energy consumption is reduced by  $171W$  in the process of the motor's start-up acceleration when the weight of energy consumption performance index is the biggest. For the energy-saving considerations, the energy saving effect is obviously

better than the traditional method when the weight of energy consumption index is set to the highest.

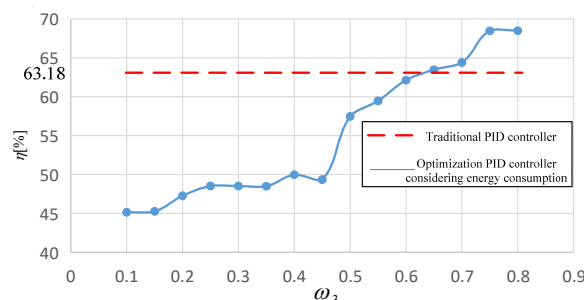

Fig. 4 Energy efficiency curve

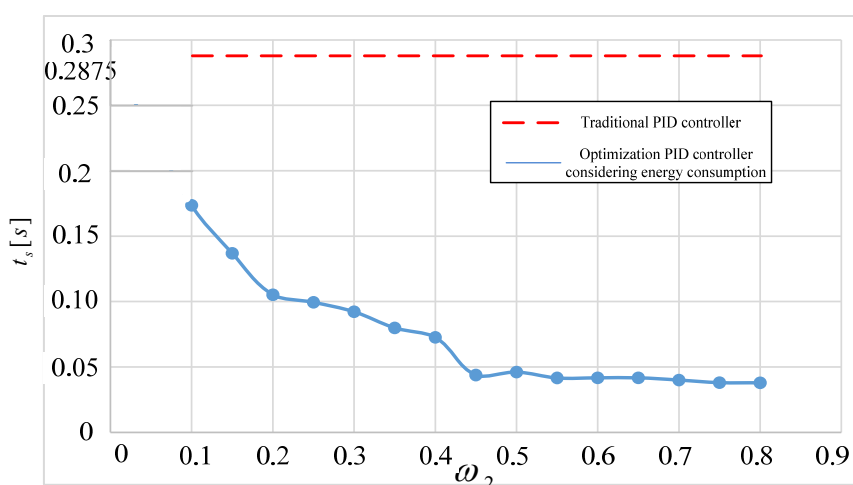

Fig. 5 Response time curve

The weight of the rapidity index and steady-state time in Table IV are extracted as in Fig. 5. The weight of energy consumption performance index increases while the weight of the rapidity index decreases gradually. In other words, the higher the rapidity weight, the shorter the response time. From Fig. 5, with the increase of the weight of the rapidity index, the setting time gradually decreases from 0.1736s to 0.0379s. It can be learned that the bigger the setting time, the higher the energy efficiency. This is because in order to achieve steady state more quickly, the overshoot value is larger, and larger overshoot results in wasted energy as will be illustrated in Fig. 7. With the comprehensive performance index control method considering energy consumption, the energy efficiency can be significantly improved by slightly sacrificing the response time. However the setting time obtained by the traditional PID controller is 0.2875s which is much worse than the method considering the energy consumption. Our results indicate that the proposed method considering energy consumption may also have significance good effects on rapidly performance.

The optimization curves have been drawn in Fig. 6 based on the selected 3 sets of data from Table IV. These 3 sets of data are the optimization results of control parameters when  $\omega_2$  in

(15) is equal to 0.1, 0.45, and 0.8 respectively. As can be seen from Fig. 6, the convergence rate and the best fitness value of the optimization curve using the same algorithm are different due to different weight coefficients of rapidity. The iterations are 8, 10, and 11 when it converges to the best fitness value. It can be concluded that the greater the weight of rapidity, the faster the convergence. And this also conforms to the pattern shown in Figs. 5 and 7. Due to the different weight coefficients, the optimal fitness values of the 3 sets of data also converge to different ones. Then the optimized parameters are brought into the simulation model of the integrated control model of DC motor with the consideration of energy consumption. Fig. 7 shows that the armature current of the DC motor with the two methods are both well tracked and the steady-state error is less than 2A. The method proposed in this paper achieves stable state more quickly than the old one. Furthermore, the bigger the  $\omega_2$  is, the quicker the response and the faster the response, the greater the overshoot which leads to lower energy efficiency and higher energy consumption. During the motor start-up process, energy consumption is positively correlated with the integral of control quantity over setting time. When the response time is

small, such as the adjustment time within the range of 0.0379 to 0.1736, it can be approximately considered that energy consumption is positively correlated with the overshoot. Therefore the overshoot is the largest and the energy consumption is the largest when the maximum value of  $\omega_2$  is 0.9. However, the overshoot of the traditional PID control method is not the maximum while the corresponding energy consumption is the largest. The setting time is 0.2875, much

higher than 0.1736, resulting in a large integral value of the signal to time. The integral of overshoot value over setting time is positively correlated with energy consumption. From Fig. 7 the traditional PID controller has bigger overshoot value and longer setting time so that the energy consumption is much more than the proposed method this paper. Therefore the energy consumption is the largest with the conventional approach.

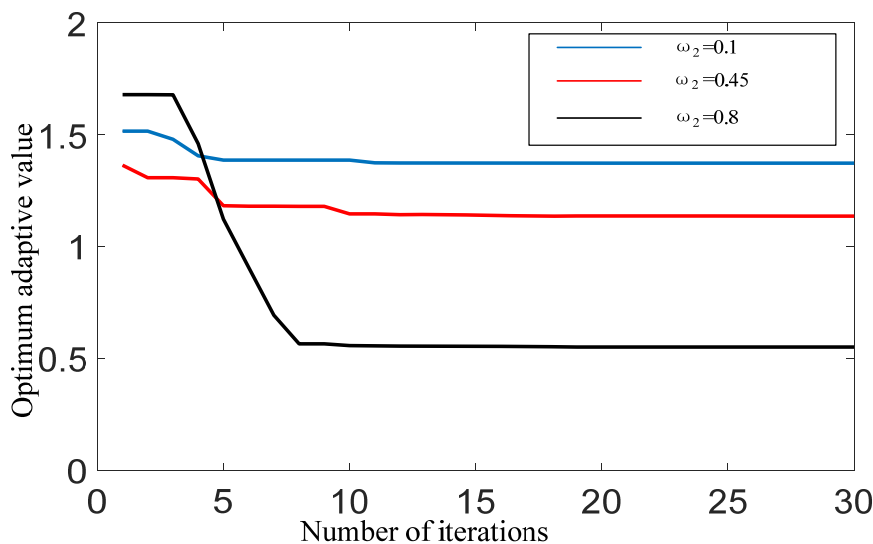

Fig. 6 Optimization curve

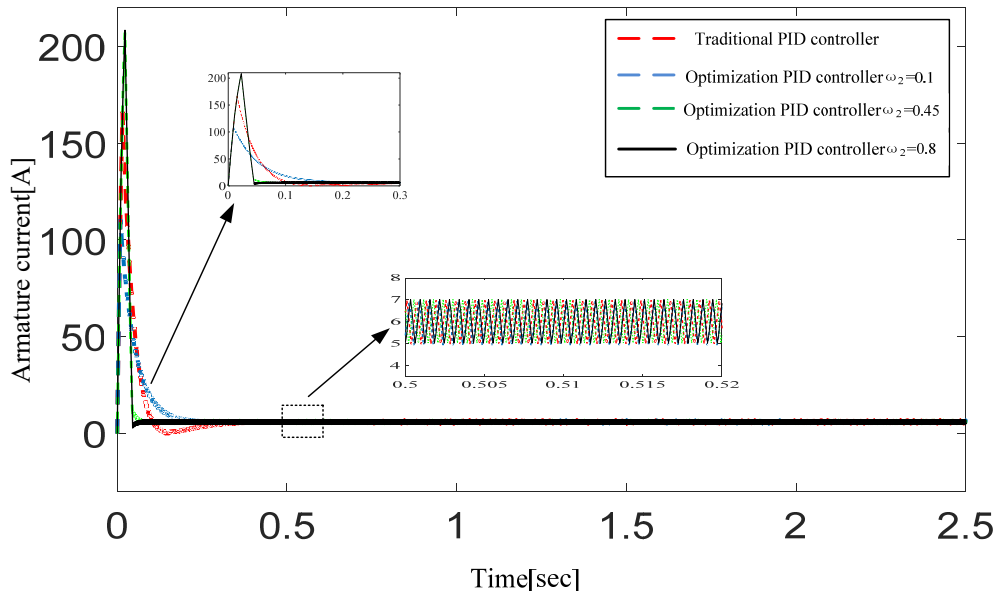

Fig. 7 Armature current tracking curve

In summary, the comprehensive performance optimization control algorithm with the consideration of energy consumption is convergent and has better dynamic and performance and steady-state error than the traditional PID method. More importantly, it also has outstanding energy efficiency.

## VI. CONCLUSION

In order to reduce the energy consumption of DC motor in the process of starting, a comprehensive performance index method based on particle swarm optimization considering energy consumption is proposed. The research shows that compared with the traditional method, this method has a very good effect on energy saving and the effect of energy saving is

better as the weight of energy consumption performance index increases. Furthermore, the proposed method is also remarkably effective in reducing the start-up process time. This paper proposed a method for the study of energy saving control, but the comprehensive performance index method considering energy consumption also has some shortcomings. In order to reduce energy consumption, the maximum overshoot of the armature current may exceed the rating of the DC motor, and the next step is to add some constraints to insure the instantaneous current within a reasonable range.

#### REFERENCES

- [1] Ren Xingquan, "The application of modern control theory in electric drive system," *Metallurgical automation*, no.4, pp.34-40,65,1985.
- [2] Ren Xingquan, "Application of optimal control theory in electric d-rag system-optimal control of electric drag," *Control engineering*, no.4, pp.1-7,1994.
- [3] Hu Zhongji, Zheng Fangjing, Lin Dongqing, etc. "Minimum energy consumption control for dynamic systems," *Metallurgical automation*, no.5, pp.31-34,1982.
- [4] Tong Tiaosheng, "The minimum energy consumption control of armature inductor and the algorithm of singular solution are considered," *Journal of automation*, vol.14, no.3, pp.199-206,1988.
- [5] Yamashita M, Fujisawa K, Fukuda M, et al. "A quadratic programming solution of the minimum energy control problem," *IEEE Transactions on Automatic Control*, vol.13,no.2,pp.206-207,1968.
- [6] Cabezas Rebolledo A, Valenzuela M A. Expected Savings Using Loss-Minimizing Flux on IM Drives—Part I: Optimum Flux and Power Savings for Minimum Losses (J). *IEEE Transactions on Industry Applications*,2015,51(2):1408-1416
- [7] Kokotovic P, Singh G, "Minimum-energy control of a traction motor," *IEEE Transactions on Automatic Control*, vol.17, no.1, pp.92-95,1972.
- [8] Gray C, "Minimum energy control of systems using state controls," *IEEE Transactions on Automatic Control*, vol. 19, no.4, pp.367-373, 1974.
- [9] Ren Xingquan, "Optimal position control and accurate positioning of DC drive system," *Metallurgical automation*, no.3, pp.25-31,1982.
- [10] Hu Zhongji, "Minimum energy consumption control and its application," *Manufacturing automation*, no.4, pp.12-15,1982.
- [11] Ren Xingquan, Tian Yang, "The closed loop optimal control system of electric drive with minimum energy consumption," *Angang automation*, no.3,pp.1-6,1992.
- [12] Hu Soutao, Wang Zhiquan, and Hu Weili, "Optimal control theory and system," Beijing: science press, 2005.
- [13] Egami T, Morita H, Tsuchiya T. Efficiency optimized model reference adaptive control system for a DC motor (J). *IEEE Transactions on Industrial Electronics*, 1990, 37(1):28-33.
- [14] Aghili F. Energy-Efficient and Fault-Tolerant Control of Multiphase Nonsinusoidal PM Synchronous Machines (J). *IEEE/ASME Transactions on Mechatronics*, 2015, 20(6):2736-2751.
- [15] Mademlis C, Kioskeridis I, Theodoulidis T. Optimization of Single-Phase Induction Motors— Part I: Maximum Energy Efficiency Control (J). *IEEE Transactions on Energy Conversion*, 2005, 20(1):187-195.
- [16] J. D. Law, T. A. Lipo, "A single phase induction motor voltage controller with improved performance", *IEEE Trans. Power Electron.*, vol. PE-1, no. 4, pp. 240-247, Oct. 1986.
- [17] Honda A, Kawano M, Ishida M, et al. Energy Optimization of Field Oriented Six-Phase Induction Motor Drive (J). *Advances in Electrical & Computer Engineering*, 2011, 11(2):107-112.
- [18] Ali M M I. Efficiency optimisation with PI gain adaptation of field-oriented control applied on five phase induction motor using AI technique (J). *International Journal of Modelling Identification & Control*, 2013, 20(4):344-360.
- [19] L. Lu, H. Chen, Y. Hu, X. Gong and Z. Zhao, "Modeling and Optimization Control for an Engine Electrified Cooling System to Minimize Fuel Consumption," in *IEEE Access*, vol. 7, pp. 72914-72927, 2019.doi: 10.1109/ACCESS.2019.2917333
- [20] Yingjie Zhang, Ying Zhang, and Zhaoyang Ai. "Energy Saving Control Strategy for the High-Frequency Start-up Process for Electric Mining Haul Trucks," *IEEE Transactions on Intelligent Vehicles*, vol.3, no.4, pp.595-606,2018.
- [21] Y. Zhang, Y. Zhang, Z. Ai, M. Yi Lu and J. Zhang, "Energy Optimal Control of Motor Drive System for Extending Ranges of Electric Vehicles," in *IEEE Transactions on Industrial Electronics*. Doi: 10.1109/TIE.2019.2947841
- [22] W. R. Provancher, S. I. Jensen-Segal and M. A. Fehlberg, "ROCR: An Energy-Efficient Dynamic Wall-Climbing Robot," in *IEEE/ASME Transactions on Mechatronics*, vol. 16, no. 5, pp. 897-906, Oct. 2011.doi: 10.1109/TMECH.2010.2053379
- [23] Sarkar M, Nandy S, Shome S N. Energy Efficient Trajectory Tracking Controller for Underwater Applications: A Robust Approach (J). *Aquatic Procedia*,2015,4:571-578
- [24] Zoutendijk G, "Methods of feasible directions," *Mathematical Gazette*, vol. 46, no.46, pp.389-418, 1960.
- [25] Bi Daqing, Peng Zishun, Gao Kecun, etc. "Particle swarm optimization algorithm and its application in power electronic control," Beijing: science press, 2016.