

# Double Loop Control of H-Bridge DC Chopper Fed Permanent Magnet DC Motor Drives Using Low Cost Hardware

Zin Maw Tun, Tun Lin Naing

**Abstract**—This paper presents the two loop proportional integral (PI) controller for speed control of permanent magnet DC motor (PMDC) motor drive with H-bridge DC chopper. PMDC motors are widely used in many applications because of having a good performance and it is easy to apply the speed control. The speed can be adjusted by using armature voltage control as it had only the armature circuit. H-bridge DC chopper circuit is used to obtain the desired speed in any direction. In this system, the two loop PI controller is designed by using pole-zero cancellation method. The speed and current controller gains are considered depending on the sampling frequency of the microcontroller. An Arduino IO package is used to implement the control algorithm. Both simulation and experimental results are presented to prove the correctness of the mathematical model.

**Keywords**—Arduino IO package, double loop PI controller, H-bridge DC chopper, low cost hardware, PMDC motor.

## I. INTRODUCTION

DEVELOPMENT of high performance motor drives is very necessary parts of some industrial applications such as hybrid electric vehicle. A high performance motor drive system has special characteristics such as good dynamic speed command tracking capability and load regulating response [1]. There are two types of motor drive: DC drives and AC drives [2]. DC drives have long been a backbone of industrial applications because of their benefits, like simplicity, reliability and favorable cost. DC drives have not only less complexity but are also less expensive as compared with AC drives [2], [3]. Therefore, the DC drives are still widely used in many applications requiring good speed regulation, adjustable speed control, operating with frequent starting, braking and reversal of motor [3]. Some important industrial applications are rolling mills, paper mills, hoists, printing presses, machine tools, textile mills, excavators and cranes [3]-[5]. For industrial applications, high performance motor drives are very necessary to operate in all four quadrants. The PMDC motors are used in adjustable speed drives because of considering only the armature circuit [4].

An electrical drive system consists of electric motors, power circuit, controller and energy conversion circuit. In modern electrical drive system, power electronic converters

are extensively used for adjustable frequency and voltage control [5]. The power supply in electrical drives is provided by an AC or DC source. The power semiconductor devices such as thyristor, power BJT, MOSFET, IGBT and GTO based chopper are used for a chopper circuit to operate in any direction of the desired speed. The performance of DC motor drives system can be studied with AC/DC buck-boost converter [6], DC/DC buck-boost converter [7], boost-converter-inverter [8] and buck converter [9]. These converters are employed for an AC to DC conversion and a DC to DC conversion stage for effective voltage control. Moreover, the DC motor drives supplied from a DC source using the H-bridge chopper circuit are found in [3], [10].

In motion control application, the motor speed should be closely similar to the reference speed in any changed situations. Therefore, it is important to choose the controller and controller design method. In DC motor speed control, the single loop control structure caused higher starting current and reduced the disturbance rejection. Therefore, the cascade control configuration is widely used in DC motor speed control system because of its good dynamic performance [11], [12], [19]. The literature presents various controller design methods that can be divided into trial and error tuning of the controller [1], Ziegler Nichols tuning rules [13], and transfer function approach [14]. The closed loop four quadrant speed control of chopper fed DC motor has been analyzed depending on set point and control variable changes by using SCADA based GUI [15]. In recent years, the low-cost hardware and many controller methods such as PI, PID and FLC are used in the DC motor control system [16]-[18].

The objective of this paper is to present the two loop control structures by using low-cost control implementation. In this system, the motor parameters and controller gains are related to each other because of applying the pole-zero cancellation approaches [19]. The low cost implementation system is more favorable cost and easy to use than the use of high speed processor. An Arduino Nano is more economical than DSP and other high speed processors [1], [20]. And then, the control structure is more awareness and user-friendly of language by using MATLAB support packages.

The proposed two loop control system has many advantages for speed and current control of four quadrant PMDC motor drives. The advantages of two loop systems compared to single loop are the faster response and good performance [19]. Moreover, the speed response reaches the steady state condition faster because of reducing the time constant of the

Zin Maw Tun is with the Mandalay Technological University, Mandalay, Myanmar (e-mail: zinmawtun070965@gmail.com).

Tun Lin Naing is with the Department of Electrical Power Engineering, Mandalay Technological University, Mandalay, Myanmar (e-mail: tunlinnaing1980@gmail.com).

system. Speed and current of PMDC motor are generally controlled by cascade connected controllers. Experimental works including with forward and reverse speed performance and load torque disturbance are carried out by Arduino based control.

The structure of this paper is as follows. Section II illustrates the principle and operation of four quadrant chopper fed PMDC motor. Section III presents the transfer function of a PMDC motor. Section IV presents the proposed control structure and selection of controller gains. The simulation results of four quadrants PMDC motor drive are presented in Section V. The experimental results of motor drives and other scheme are provided in Section VI. Section VII describes the conclusion of this paper.

## II. PRINCIPLE AND OPERATION OF FOUR QUADRANT DC-DC CONVERTER

A DC chopper or DC-DC converter is a static device which is used to get variable DC voltage from a fixed DC voltage for variable speed drives. They are also used for DC motor control and also can run the motor in all 4-quadrant of speed torque plane.

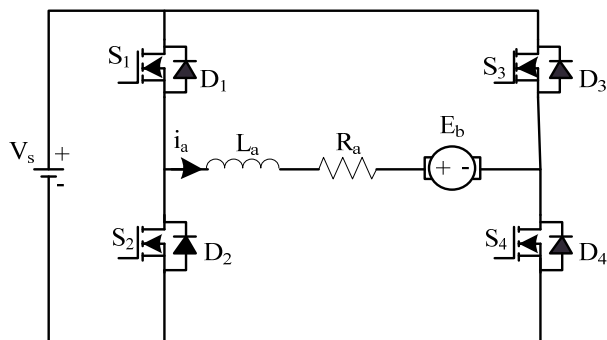

Fig. 1 Chopper Fed Four Quadrant PMDC Motor

### A. Four-Quadrant Operations

The four quadrant chopper operates in the four quadrants in the followings ways:

1. First Quadrant: The first quadrant operation begins with the positive voltage and current to the motor. Therefore, the input power is positive. In this quadrant, both  $S_1$  and  $S_4$  are ON, i.e.  $S_1$  is modulating and  $S_4$  is continuously

ON. In this way, positive direction of both voltage and current can be achieved and motor will rotate with forward direction. In this mode, the power flows from the supply to motor.

2. Second Quadrant: The second quadrant operation begins with positive voltage and negative current, the power is negative. In this condition, the power flows from load to the source operating in negative direction. When the switch  $S_2$  is turned ON, both the switches  $S_1$  and  $S_3$  are turned OFF. Since the direction of inductor current cannot be reversed instantaneously,  $S_4$  and  $D_2$  will be conducting the freewheeling the current.
3. Third Quadrant: Third quadrant operation corresponds to a negative output voltage and negative current, achieved by triggering Switches  $S_3$  and  $S_2$  as shown in Fig. 2 (c). The voltage and current across the load are negative driving the motor in reverse direction. The motor speed can be varied by changing the duty cycle  $d$  of the switch  $S_3$ .
4. Fourth Quadrant: The fourth quadrant operation corresponds to a negative current and positive voltage, power becomes negative. When the switch  $S_4$  is turned on, the voltage across the armature inductance increases. When the switch  $S_4$  is turned OFF, the voltage is passed through the armature inductance and back EMF. If the output voltage is more than source voltage, the mechanical energy is feed back to the battery as the electrical energy.

### B. Average Model of Converter System

The H-bridge DC-DC converters are extensively used in PMDC motor drives, the input is a fixed magnitude voltage  $V_s$ . The output voltage can be controlled both in magnitude as well as direction.

A high frequency saw tooth wave is compared with control voltages  $V_c$  and for determining the switching signals with duty cycle. Therefore the average output voltage  $v_a$  in this switching scheme is same as bipolar switching scheme.

$$S_1 \text{ is on if } V_c > V_{ref}, S_2 = \bar{S}_1$$

$$S_2 \text{ is on if } V_c < V_{ref}, S_4 = \bar{S}_3$$

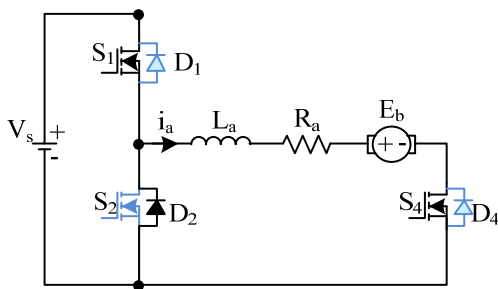

(a)

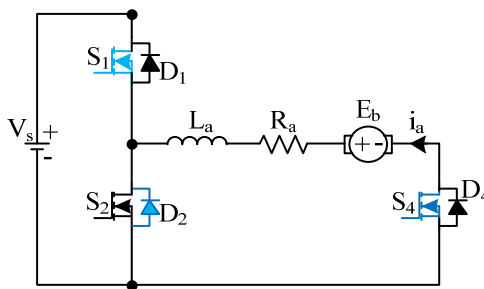

(b)

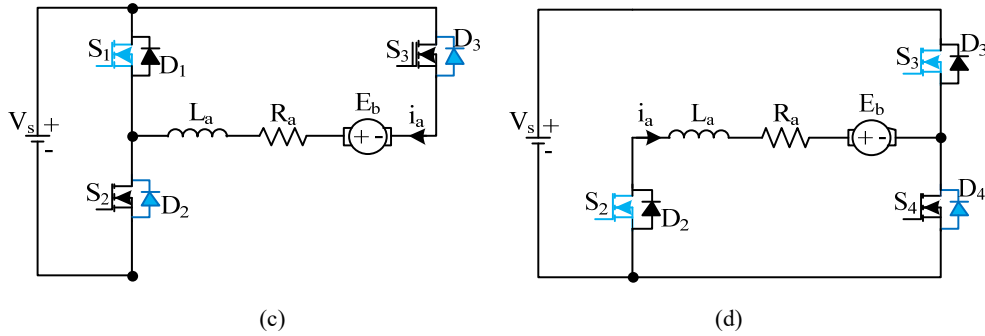

Fig. 2 Schematic show switching type of triggering in all quadrants (a) First Quadrant (b) Second Quadrant (c) Third Quadrant (d) Fourth quadrant

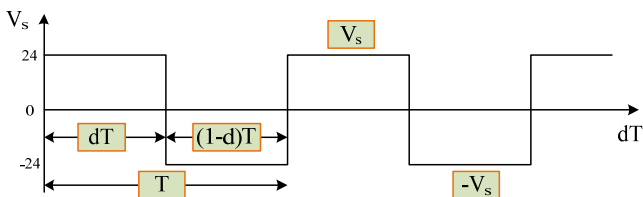

Fig. 3 Voltage Waveform of Bipolar PWM

The average model of the converter system is,

$$v_a = \frac{1}{T} \int V_s ds$$

$$v_a = \frac{1}{T} \left[ \int_0^{dT} V_s ds + \int_{dT}^T -V_s ds \right]$$

$$v_a = \frac{1}{T} [2dT V_s - V_s T]$$

$$v_a = (2d - 1) V_s \quad (1)$$

This model can be used in simulation work of PMDC motor drive system.

### III. TRANSFER FUNCTION OF PMDC MOTOR

PMDC motors are widely used in many applications because of having a good performance and it is easy to control the motor speed. Their speed can be adjusted by using

armature voltage control as it has only the armature circuit. Fig. 4 shows the electromechanical device, the motor and generator set from power electronic lab, Department of Electrical Power Engineering, MTU. For feedback control purpose, it is very important to consider electrical and mechanical dynamics of the motor generator set.

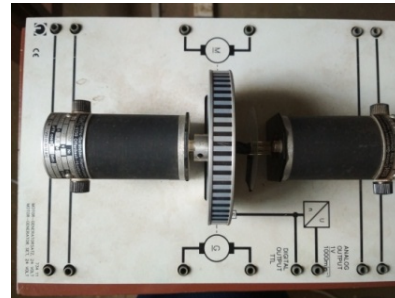
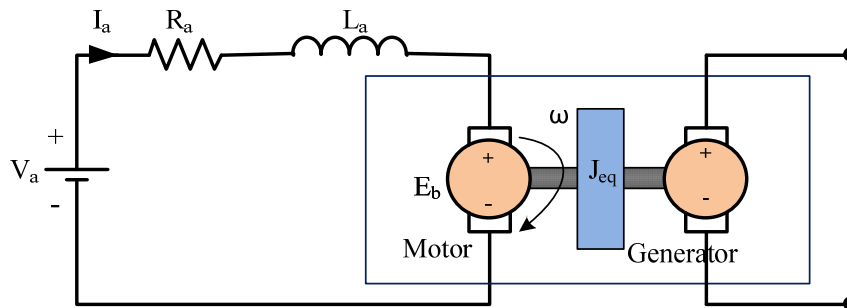

Fig. 4 Photo of Motor and Generator Set

The equivalent circuit of the PMDC motor and generator set is shown in Fig 5, where \$V\_a\$ is the armature voltage to the PMDC motor in volts, \$R\_a\$ and \$I\_a\$ are the resistance and current of the armature, \$L\_a\$ is the inductance of the armature windings, and \$E\_b\$ is the back EMF. \$T\_c\$ is the electromechanical torque (N.m), \$J\_{eq}\$ is the moment of inertia of the motor plus flywheel plus generator (kg.m<sup>2</sup>), \$B\$ is the viscous friction coefficient (N.m.s/rad), and \$\omega\$ is the angular speed of the DC motor (rad/sec). \$K\_b\$ is back EMF constant (V/rad/s) and \$K\_t\$ is torque constant (N.m/A).



Motor and Generator Set

Fig. 5 Equivalent Circuit of PMDC Motor and Generator set

The mathematical model of the electrical circuit of the PMDC motor can be obtained by applying Kirchoff's voltage law (KVL). The electrical circuit equations are:

$$v_a = R_a i_a + L_a \frac{di_a}{dt} + E_b \quad (2)$$

$$E_b = K_b \omega \quad (3)$$

When a DC motor with the output torque is driving a mechanical load system;

$$T_e = J_{eq} \frac{d\omega}{dt} + B\omega + T_L \quad (4)$$

$$T_e = K_t i_a \quad (5)$$

In equilibrium condition, mechanical power output equals to electrical power input. Therefore,  $P_m = P_e$ ,  $T_e \omega = E_a I_a$ ,  $K_t I_a \omega = K_b \omega I_a$ ,  $K_b = K_t$ .

The differential equations for armature current and angular velocity derived from (2) through (5) are shown in (6) and (7) respectively.

$$\frac{di_a(t)}{dt} = \frac{R_a}{L_a} i_a(t) - \frac{K_b}{L_a} \omega(t) + \frac{1}{L_a} v_a(t) \quad (6)$$

$$\frac{d\omega(t)}{dt} = \frac{K_t}{J_{eq}} i_a(t) - \frac{B}{J_{eq}} \omega(t) - \frac{1}{J_{eq}} T_L(t) \quad (7)$$

By applying Laplace transform of (6) and (7), the block diagram model of the PMDC motor shown in Fig 6 is obtained.

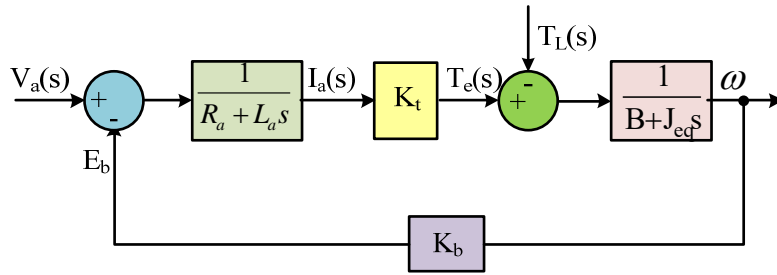

Fig. 6 Block Diagram of PMDC Motor Model

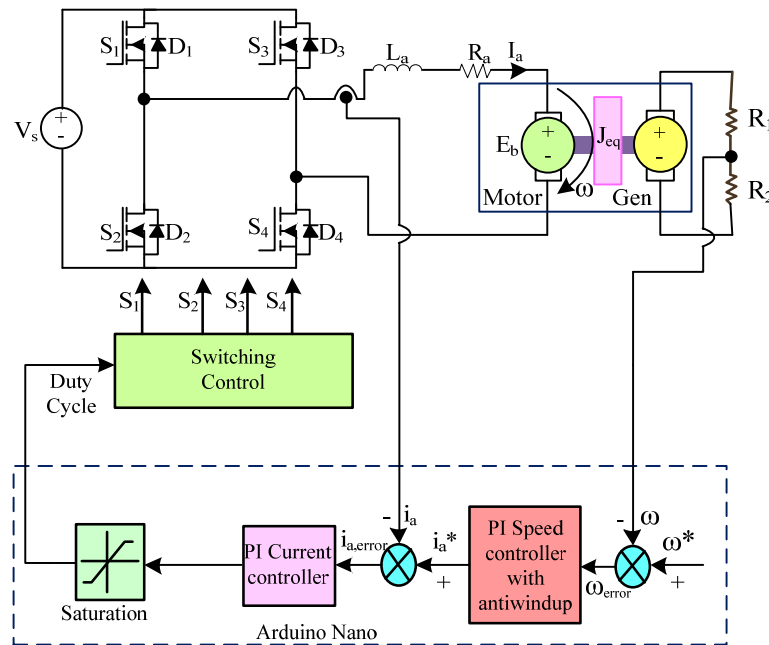

Fig. 5 Four Quadrant DC Motor with Control Scheme

The transfer function is obtained from the block diagram of PMDC motor. Relation of the output speed  $\omega(s)$  to the input voltage  $V_a(s)$  can be expressed in the form of

$$\frac{\omega(s)}{v_a(s)} = \frac{K_t}{(L_a s + R_a)(J_{eq} s + B) + K_t K_b} \quad (8)$$

The block diagram of PMDC motor will be used to find the

controller gains in the next section.

#### IV. CONTROL IMPLEMENTATION

The circuit diagram of H-bridge chopper fed PMDC motor with control structure is illustrated in Fig. 7. In the processor, the two loop controller can be seen for controlling the motor speed. The back EMF of the motor is neglected in the control system. The outer loop PI controller limited the current reference and the inner loop is the limitation of duty cycle for switching signal.

The H-bridge DC chopper fed PMDC motor with two loop PI control structure can be expressed as follow.

#### A. Two Loop Control Structure

Fig 8 illustrates the cascade PI closed-loop control system of PMDC motor for current and speed control. In this figure, the PI controller for speed and current control  $G_{cs}$  and  $G_{cc}$  are described as follow. The PI controller has two parameters, the proportional  $K_p$  and integral  $K_i$  controller.

$$G_{cs}(s) = K_{ps} + \frac{K_{is}}{s} \quad (9)$$

$$G_{cc}(s) = K_{pc} + \frac{K_{ic}}{s} \quad (10)$$

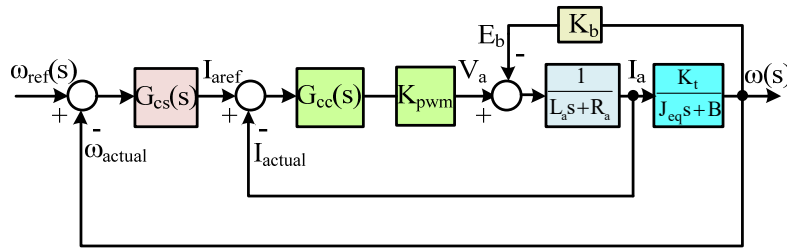

Fig. 8 Block Diagram of Closed Loop Control System

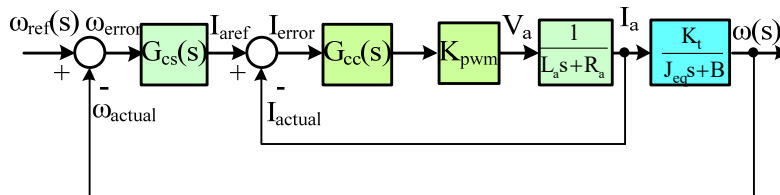

Fig. 9 Closed-Loop Control System of PMDC Motor after Back EMF Compensation

The transfer function of current loop control is illustrated in (10) from the inner loop of block diagram.

$$I_a(s) = \begin{pmatrix} \frac{(K_{pc}s + K_{ic})K_{PWM}}{L_a s^2 + R_a s + K_{pc}K_{PWM}s + K_{ic}K_{PWM}} I_a^*(s) \\ - \frac{E_b(s)}{L_a s^2 + R_a s + K_{pc}K_{PWM}s + K_{ic}K_{PWM}} \end{pmatrix} \quad (11)$$

The back EMF  $E_b$  of the PMDC motor acts as a disturbance of the current controller. Although the large motor is significant by affecting the disturbance due to back EMF, the effect of the back EMF disturbance is slightly to neglect in the small motor. In this paper, the back EMF is neglected when the current loop is considered. Therefore, the transfer function of current loop control is form of

$$I_a(s) = \frac{(K_{pc}s + K_{ic})K_{PWM}}{L_a s^2 + R_a s + K_{pc}K_{PWM}s + K_{ic}K_{PWM}} I_a^*(s) \quad (12)$$

The two loop control system of PMDC motor neglecting the back EMF is formed as Fig. 9.

#### B. Current Controller Gain

The controller gain will be designed and tuned by using the pole-zero cancellation method. These methods related the motor parameters and system controller gain.

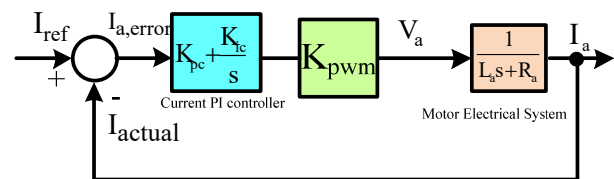

Fig. 10 Block Diagram of PI Current Control System

The open-loop transfer function  $G_c(s)$  of this system is given by

$$G_c(s) = K_{pc} \left[ \frac{s + \frac{K_{ic}}{K_{pc}}}{s} \right] \times \frac{1}{L_a} \times \frac{R_a}{s + \frac{R_a}{L_a}} \times K_{PWM} \quad (13)$$

where,  $K_{PWM}$  is the gain constant of the PWM converter. A gain constant  $K_{PWM}$  represents the switch mode DC-DC

converter and PWM controller.

$$K_{PWM} = \frac{V_s}{V_{tri}} = \frac{24}{5} = 4.8$$

If the zero of the PI controller is designed to cancel the pole of the DC motor by the pole-zero cancellation method,

$$\frac{R_a}{L_a} = \frac{K_{ic}}{K_{pc}}$$

$$G_c(j\omega_{cc}) = \frac{1}{\left(\frac{L_a}{K_{pc}K_{PWM}}\right)\omega_{cc}} = 1$$

$$\omega_{cc} = \frac{K_{pc}K_{PWM}}{L_a}$$

The proportional gain  $K_{pc}$  and the integral gain  $K_{ic}$  can be obtained from (13) and (14).

$$K_{pc} = \frac{L_a\omega_{cc}}{K_{PWM}} \quad (14)$$

$$K_{ic} = \frac{R_a}{L_a} K_{pc} = \frac{R_a\omega_{cc}}{K_{PWM}} \quad (15)$$

The design of controller gains depends on the armature resistance and armature inductance.

### C. Speed Controller Gain

The speed controller gain is chosen as simple PI compensation law as follows:

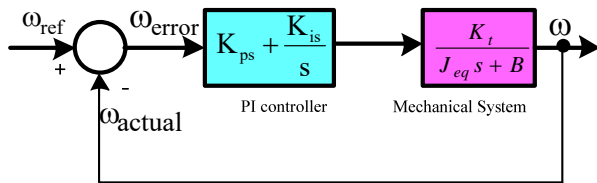

Fig. 11 Block Diagram of Speed Loop Control

In the PI controller,  $K_{ps}$  and  $K_{is}$  represent the proportional and integral gains of the speed control. The open-loop transfer function  $G_{cs}(s)$  of this system is given by

$$G_{cs}(s) = K_{ps} \left( \frac{s + \frac{K_{is}}{K_{ps}}}{s} \right) \frac{K_t}{J_{eq} s + B}$$

The proportional gain of speed controller  $K_{is}$  and the integral gain of speed controller  $K_{ps}$  are expressed in (16) and (17).

$$K_{is} = \frac{B\omega_{cs}}{K_t} \quad (16)$$

$$K_{ps} = \frac{J_{eq}\omega_{cs}}{K_t} \quad (17)$$

The speed controller gain depends on the motor parameters  $J_{eq}$  and  $B$  and the torque constant  $K_t$  of the motor.

### D. Selection of Controller Gain

If the controller gain is designed, the selection of gain cross over frequency  $\omega_{cc}$  is required. The bandwidth  $\omega_{cc}$  of a current controller is limited by two factors; the switching frequency and sampling frequency. It is desirable to restrict the bandwidth to 1/25 of the sampling frequency.

$$f_{cc} = \frac{1}{25} \times \text{sampling frequency} \quad (18)$$

$$\omega_{cc} = 2\pi f_{cc}$$

The sampling frequency is obtained from sample time 0.002 sec. The sampling frequency is taken 50% of 500 Hz to calculate the cross over frequency  $f_{cc}$ . The cross over frequency of the speed control loop,  $\omega_{cs}$  was chosen to be 10 times smaller than  $\omega_{cc}$  in [19]. In this paper, the bandwidth of the speed controller  $\omega_{cs}$  can be chosen up to one-fifth of the current controller because of having a large bandwidth and faster the response than one-tenth of the current controller.

$$\omega_{cs} = \frac{\omega_{cc}}{5} \quad (19)$$

The parameters value of PMDC motor is described in Table I.

Parameters	Values
Rated voltage	20 V
Rated power	3.8 W
Rated speed	3000 rpm
Rated current	0.47 A
Armature resistance	8.5 ohm
Armature inductance	5.621 mH
Back EMF constant	0.062 V.s/rad
Motor torque constant	0.062 N.m/A
Viscous friction	$5.663 \times 10^{-5}$ N.m.sec/rad
Moment of inertia	$5.902 \times 10^{-4}$ kg-m <sup>2</sup>

The current controller gain can be obtained from (14), (15) and (18). The value of armature resistance is obtained from Table I.

The speed controller gains can be obtained from (16), (17) and (19). The current and speed controller gains are chosen depending upon the sampling frequency 500 Hz. The PI controller gains for speed and current controller are expressed in Table II.

TABLE II  
 CONTROLLER GAIN VALUES

Controller gain	Value
$K_{pc}$	0.0074
$K_{ic}$	111.26
$K_{ps}$	0.119
$K_{is}$	0.0115

E. PI controller with Anti-windup Design

There are several methods to eliminate the integrator windup such as back calculation, conditional integration, and limited integration. The PI controller with integrator windup reduces the overshoot and simple implementation in the exciting system in [21]. The anti-windup scheme of back calculation as shown in Fig 12 is widely used because of its satisfactory dynamic characteristic.

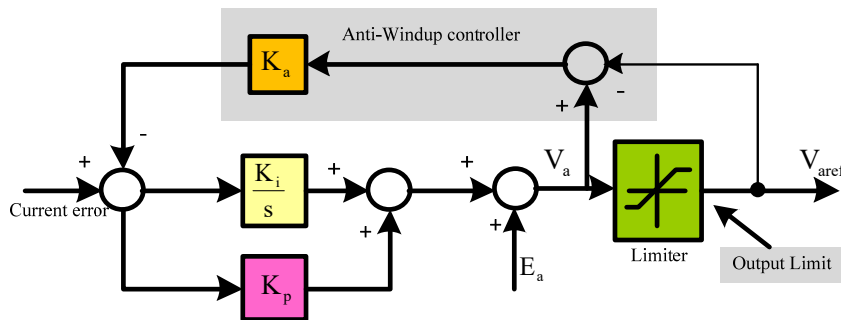

Fig. 12 Anti-windup PI Controller by Back Calculation Method

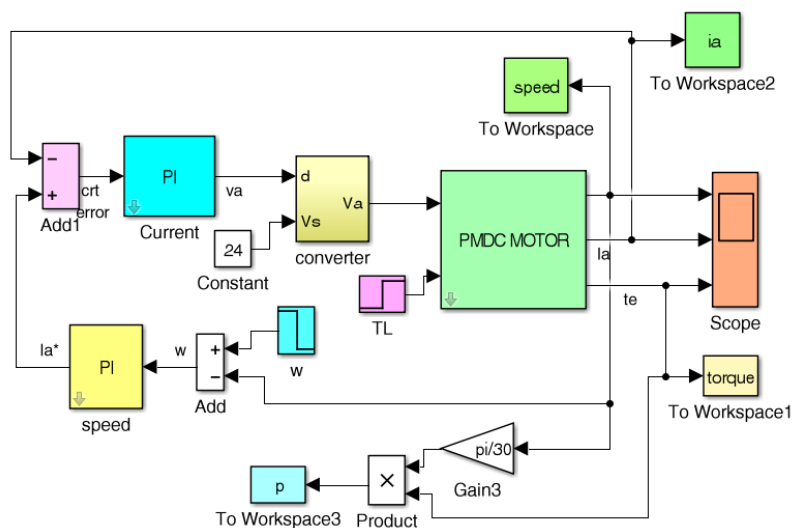

Fig. 13 Simulation Block Diagram of Close Loop System

The proposed system will be used in the next section for limiting the current reference in speed controller.

V. SIMULATION WORK

In this section, the simulation model and results are presented. The closed loop control system of simulation block diagram is proposed to perform the forward and reverse operation of PMDC motor. In this system, the motor is operated not only load torque disturbance but also no load condition.

The simulation result of motor speed, armature current, torque and power is proposed. In Fig 15, the close-loop response of motor speed, armature current, torque and power is presented from simulation result.

The load torque 0.0051 Nm is increased both forward and reverse conditions. In these conditions, the armature current

and torque increased because of increasing the load torque.

VI. EXPERIMENTAL WORK

The proposed four quadrant PMDC motor with two loop control structure has been implemented with a low-cost hardware. This proposed system mainly consists of the control circuit and power converter circuit. The power circuit of 24 V DC supply fed to an H-bridge DC chopper circuit. An Arduino is used for the control circuit. The summing amplifier circuit using LM 741 is used for higher the speed signal. The low-cost hardware implementation of experimental circuit is illustrated in Fig. 16.

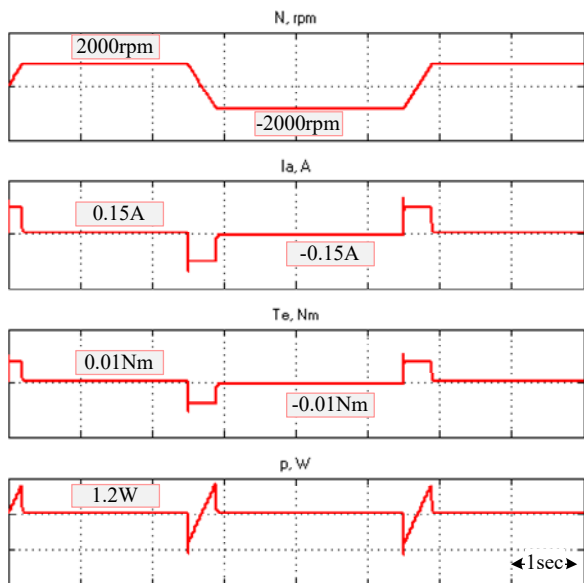

Fig. 14 Simulation Result of Forward and Reverse Speed with Two Loop PI controller

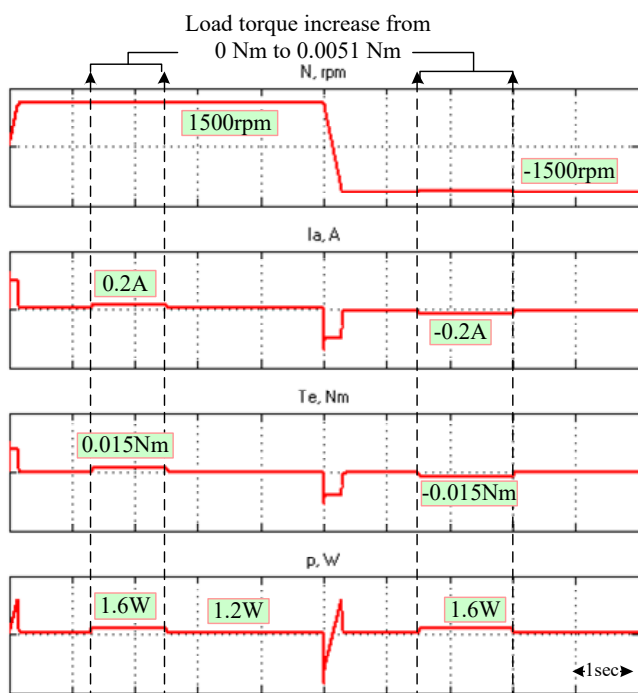

Fig. 15 Simulation Result with Load Torque Changes

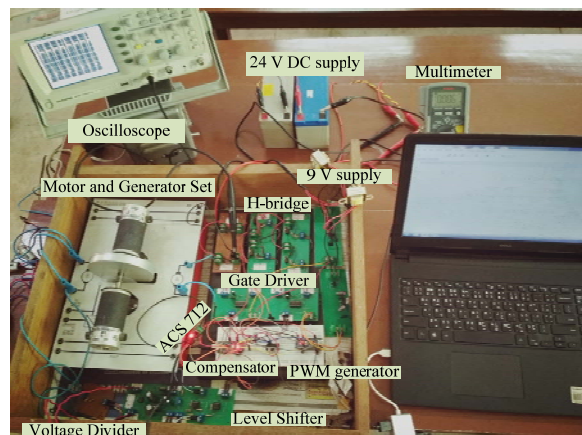

Fig. 16 Experimental Set Up with Low-Cost Hardware Implementation

The two loop PI control system of PMDC motor is presented with Simulink block from Arduino IO Library. The experimental results are generated by using Arduino IO package. The sample time is set up 0.002 sec.

The close loop response of motor speed, armature current, torque, and power at speed 2000 rpm to -2000 rpm are illustrated in Fig. 19.

In Fig. 20, the load torque from 0 to 0.051 Nm is added to the closed loop control system at 1.5 sec and 5.5 sec. In this situation, the motor speed runs at 1500 rpm to -1500 rpm.

The motor power, armature current and torque are increased when the load torque increased. Moreover, the input duty cycle is increased as the motor runs at the desired speed. In both simulation and experimental works, the motor speed does not change during the load torque changes.

## VII. CONCLUSIONS

In this paper, H-bridge DC chopper fed PMDC motor drive with double loop control structure has been proposed. The simulation work was carried out using MATLAB/Simulink. The experimental results were obtained using 24V DC supply fed H-bridge DC chopper and low-cost hardware implementation. According to the motor speed response, the two loop DC drive system applied with low cost microcontroller can give a good performance. The motor speed response is stable during the load changes in forward and reverse conditions. Therefore, the selection of current and speed controller gains, depending on the cross-over frequency  $\omega_{cc}$  at 50% of sampling frequency, is suitable to apply in DC motor drive system. Moreover, the correctness of the mathematical model was found by comparing the simulation and experimental works.



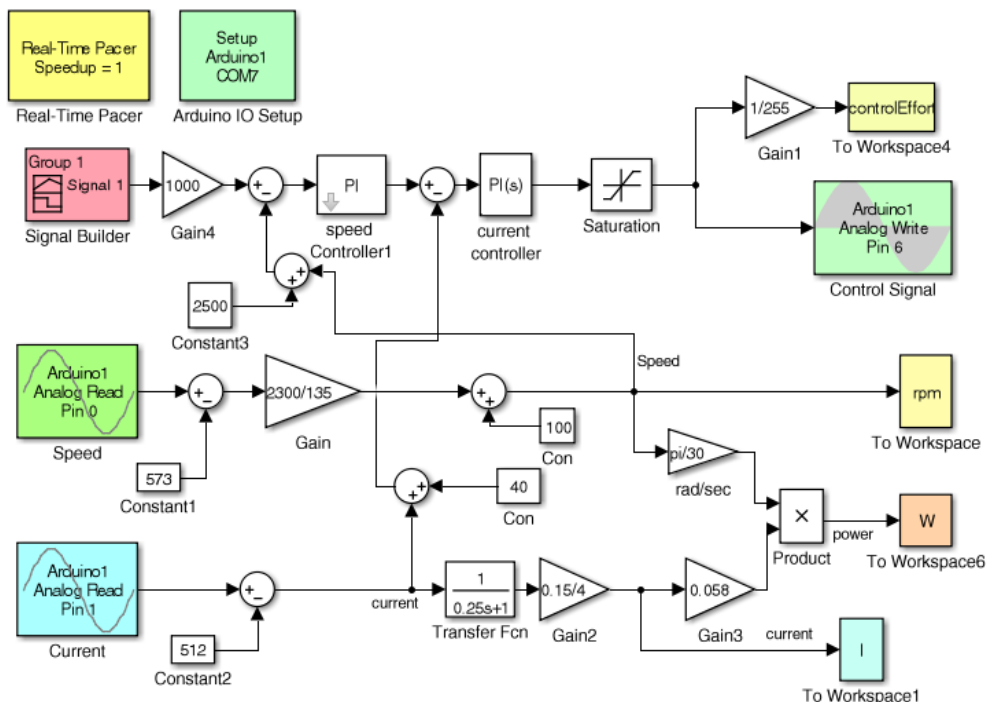

Fig. 18 Proposed Simulink Model of Closed Loop PMDC Motor Drive System

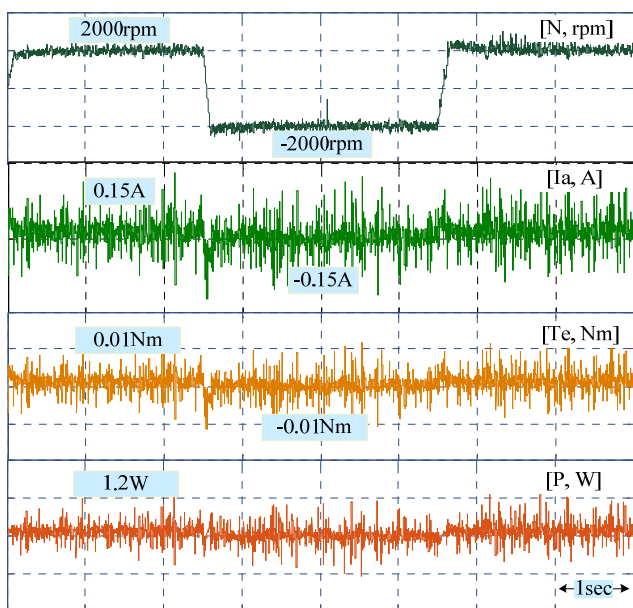

Fig. 19 Experimental Test Result of Forward and Reverse Condition

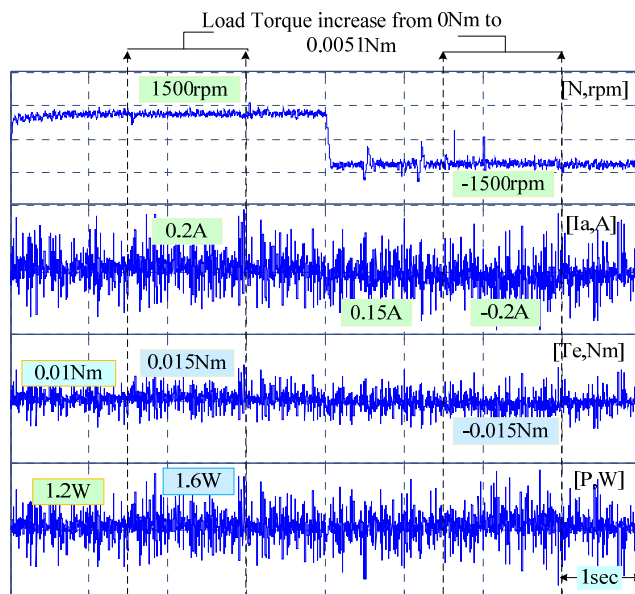

Fig. 20 Experimental Result for Two Loop Control System with Load Change

REFERENCES

- [1] Vinod S. Patil, Sachin Angadi, A.B. Raju, " Four Quadrant Close Loop Speed Control of DC Motor", International Conference on Circuits, Control, Communications and Computing (I4C), pp. 1-6, 4-6 Oct, 2016.
- [2] Zunaib Ail, Komal Saleen, Nicholas Christofides, "Performance Analysis of Fuzzy Logic Control and Six-Pulse Line-Commutated Converter in DC Motor Drive Application", IEEE, International conference on Engineering Technologies (ICET), pp. 1-6, 19-20 Dec, 2015.
- [3] Chinmay Kumar Das, Subrat Kumar Swain, "Closed Loop Speed Control of Chopper Fed DC Motor For Industrial Drive Application", IEEE, 16-18 March, 2017.

- [4] Milad Mahghani, E. Afjei, "Carrier-based with Unipolar Switching Technique Current Control of PMDC Motors in Electric Vehicle Applications", 25<sup>th</sup> Iranian Conference on Electrical Engineering (ICEE 2017), pp. 1060-1065, 2017.
- [5] Stuti, Manish Kumar Signh, Swapnil Srivastava, "ANFIS based four quadrant chopper control of separately excited DC motor: A Literature Review", 2016 International Conference on Control, Computing, Communication and Materials (ICCCCM), 2016.
- [6] Nabil A. Ahmed, "Modeling and simulation of ac-dc buck-boost converter fed dc motor with uniform PWM technique" *Electric Power System Research* 73(2005), pp. 363-372.2005.
- [7] E.H. Marquez, R.S. Ortigoza, J.R.G. Sanchez, "A New DC/DC Buck-Boost Converter-DC Motor System: Modeling and Experimental Validation", *IEEE, Trans*, Vol. 15, No. 11, NOV 2017.
- [8] R.S. Ortigoza, V.H.G. Rodriguez, E.H. Marquez, "A Trajectory Tracking Control for a Boost Converter-Inverter-DC Motor Combination", *IEEE, Trans*, Vol. 16, No. 4, April 2018.
- [9] Abdul Hamid Bhat, Tabish Nazir Mir, "Performance Investigation of a Single-Phase, Unidirectional AC/DC Buck-Converter Fed DC Motor Drive", *IEEE*, 5-7 Dec, 2014.
- [10] B. Nikhil Krishna, Budigapaka Nagaraju, "Design and Implementation of Four Quadrant DC Drive Using Chopper", 6<sup>th</sup> IEEE Power India International Conference (PIICON) 2015.
- [11] Alessandro Pisano, Alejandro Davila, Leonid Fridman, "Cascade Control of PMDC Drives via Second-Order Sliding-Mode Technique", *IEEE, Trans*, Vol. 55, No. 11, Nov 2008.
- [12] Cleber A. Ganzaroli, Douglas F. de Carvalho, "Heuristic and Deterministic Strategies applied on Cascade PI Controller Tuning for Speed Control of a DC Motor", *IEEE*, 28-30 Oct, 2015.
- [13] Rohit. G. Kanojiya, P.M. Meshram, "Optimal Tuning of PI Controller for Speed Control of DC motor drive using Particle Swarm Optimization", 2012 IEEE International conference on Advances in Power Conversion and energy Technologies (APCET), 2012.
- [14] R.M.T. Raja Ismail, M.A. Ahmad, "Speed Control of Buck-converter Driven DC Motor Based on Smooth Trajectory Tracking", *IEEE, Third Asia International Conference on Modeling and Simulation*, pp. 97-101, 2009.
- [15] Madhusudan Singh, Mini Sreejeth, Prateek Singh, "Implementation and analysis of PLC SCADA controlled closed loop four quadrant speed control of chopper fed DC motor", 2016 International Conference on Electrical Power and Energy Systems (ICEPES), Dec 14-16, IEEE, 2016.
- [16] Mario Gavran, Mato Fruk, Goran Vujisic, "PI controller for DC motor speed realized with Arduino and Simulink" *MIPRO 2017*, May 22-26, IEEE.
- [17] Wei Jie Tang, Zhen Tao Liu, Qian Wang, "DC motor speed control based on system Identification and PID auto Tuning", 36<sup>th</sup> Chinese control conference, July 26-28, 2017.
- [18] Zoheir Tir, Om Malik, Hakima Cherif, "Implementation of a Fuzzy Logic Speed Controller for a Permanent magnet DC motor using a Low-cost Arduino Platform", Oct 29-31 (ICEE-B), IEEE, 2017.
- [19] Taha Nurettin Gucin, Muhammet Biberoglu, "Tuning Cascade PI(D) Controllers in PMDC Motor Drives: A Performance Comparison for Different Types of Tuning Methods", 26-28 Nov, IEEE, 2015.
- [20] Sandhya Kumar, Dr. Anjali Deshpande, "DSP based closed loop speed control system for DC motor using Dual Converter", 2014 Annual IEEE India Conference (INDICON), 2014.
- [21] Jong-Woo Choi, Sang-Cheol Lee, "Antiwindup Strategy for PI-Type Speed Controller", *IEEE, Trans*, Vol. 56, No. 6, June 2009.