

# Development of Soft-Core System for Heart Rate and Oxygen Saturation

Caje F. Pinto, Jivan S. Parab, Gourish M. Naik

**Abstract**—This paper is about the development of non-invasive heart rate and oxygen saturation in human blood using Altera NIOS II soft-core processor system. In today's world, monitoring oxygen saturation and heart rate is very important in hospitals to keep track of low oxygen levels in blood. We have designed an Embedded System On Peripheral Chip (SOPC) reconfigurable system by interfacing two LED's of different wavelengths (660 nm/940 nm) with a single photo-detector to measure the absorptions of hemoglobin species at different wavelengths. The implementation of the interface with Finger Probe and Liquid Crystal Display (LCD) was carried out using NIOS II soft-core system running on Altera NANO DE0 board having target as Cyclone IVE. This designed system is used to monitor oxygen saturation in blood and heart rate for different test subjects. The designed NIOS II processor based non-invasive heart rate and oxygen saturation was verified with another Operon Pulse oximeter for 50 measurements on 10 different subjects. It was found that the readings taken were very close to the Operon Pulse oximeter.

**Keywords**—Heart rate, NIOS II, Oxygen Saturation, photoplethysmography, soft-core, SOPC.

## I. INTRODUCTION

ONE of the most important elements needed to sustain life is oxygen ( $O_2$ ) because it is used by cells to turn sugars into usable energy. Oxy-hemoglobin ( $HbO_2$ ) is found in red blood cells which is bonded to  $O_2$  that delivers 98% of oxygen to the cells. The measurement and calculation of oxy-hemoglobin ( $HbO_2$ ) in arterial blood is known as Oxygen Saturation ( $SpO_2$ ) [1], [2].

Originally,  $SpO_2$  was measured invasively by Arterial Blood Gas (ABG) sampling. In this technique, the blood sample is drawn from an artery and analyzed each time, the arterial blood gas provides only intermittent monitoring which may not be ideal for monitoring unstable patients. Since this technique is invasive, it is inconvenient, painful and can cause infections like arterial thrombosis and gangrene. The need for a non-invasive method of measuring  $SpO_2$  in real-time led to the development of a device to measure heart rate and oxygen saturation [2].

A healthy person should have  $SpO_2$  in between 94% to 100%. The photoplethysmography (PPG) is obtained by measuring changes in light intensity absorbed by the blood for different wavelengths. Red and near infrared wavelengths are

used because these can easily penetrate through tissues [3]. From PPG signal, oxygen saturation is derived from the ratio of the absorption of the two wavelengths [4]. It is important to monitor oxygen level in blood when the patient is in the recovery room and intensive care unit to detect hypoxemia. Also, it can be used to monitor oxygen level of a person while exercising and for normal outdoor activities.

A heart rate meter is a device that allows a person to measure and monitor their heart beat in real time. The heart rate of a healthy grown-up at rest is around 72 beats per minute (bpm) and infants is around 120 bpm, while more older kids have heart rates around 90 bpm. The heart rate rises progressively during activities and returns gradually to the rest after exercise. The rate when the beat comes back to normal value means that the individual is fit [5], [9]. If the heart rate is lower than normal value, it is known as bradycardia, if the heart rate is higher than normal value, it is known as tachycardia. Normally Heart rate is measured by placing the thumb over the person's arterial pulsation and counting the number pulses in a 60 second period [5], [9]. Heart rate measurement is very important because it indicates the efficient functioning of cardiovascular system.

The important physical property is that the blood color changes depending on oxygen saturation and hemoglobin absorbs different amounts of light. Deoxy-hemoglobin absorbs more red light than oxy-hemoglobin. As oxygen saturation falls, the blood becomes darker and more red light is absorbed. At near infrared range of light, oxy-hemoglobin absorbs more infrared light than deoxy-hemoglobin [2], [4].

## II. RELATED WORK

$SpO_2$  Sensor in a wearable Monitor was constructed using LED's/Photodiode with a signal conditioner along with Arduino Uno in [2] to measure and display oxygen saturation on the Smart Phone using Android application. Heart Rate Counter was designed using PIC16F628A along with LED's/Phototransistor with a signal conditioner in [5] to measure heart rate in relaxed state and stressed state. Reference [6] showed that Pulse Oximeter was done using Arduino Uno, LED's/detectors to calculate heart rate and oxygen saturation. Also, pressure sensor probe was used to measure blood pressure. Continuous monitoring of Pulse Rate and Oxygen saturation with LabVIEW was done by using LED driver circuit, transimpedance amplifier in [7]. The signals from the  $SpO_2$  sensor probe were fed to the amplifying circuit which was interfaced using the interfacing software 'LabVIEW' through Data Acquisition card (DAQ card) and the results were displayed in the LabVIEW front panel. Reference [8]

Caje F. Pinto is with the Department of Electronics, St. Xavier's College, Mapusa, Goa, India (Corresponding author, phone: +919823054798; e-mail: caj786@gmail.com).

Jivan S. Parab and Gourish M. Naik are with the Department of Electronics, Goa University, Taleigao, Goa, India (e-mail: jsparab@unigoa.ac.in, gmnaik@unigoa.ac.in).

showed the development of MSP based pulse oximeter with LabVIEW along with Analog Frontend (AFE4490) and Nellcor DS100A sensor probes with red LED, infrared LED and a photodiode on both sides of the probe. The measurements showed good relation with standard Contec Pulse oximeter (CMS50E). Heart Rate Monitor was designed in [9] using infrared LED and Photodiode, signal conditioner and Arduino Uno. The processing software displayed real time PPG waveform and heart rate.

### III. BLOCK DIAGRAM AND IMPLEMENTATION

Several researchers have designed non-invasive heart rate and oxygen saturation meter using different controllers, but in our design we have used NIOS II soft-core processor to design it. By using NIOS II, simplified designs can be updated to higher level, we can choose the components to build a soft-core processor running on Field Programmable Gate Array (FPGA) and rest of the FPGA hardware can be used for accelerating the parts of the code. Also, less power is consumed using NIOS II running on Cyclone IVE compared to other predefined microcontrollers.

Fig. 1 shows the design for the Non-Invasive heart rate and oxygen saturation meter. The section consists of NANO DE0 Board, Finger Probe with two LEDs of different wavelengths, a single photo detector, a signal conditioner and Liquid Crystal Display (LCD).

The LED sources are 660 nm and 940 nm. These two LED sources are controlled by NANO DE0. It sends two square

waves to turn on and off the two LEDs in such a way that both LED's are not on at the same time. To control the light intensity, a resistor is added with each LED. Behind the finger, a photo detector is used to convert the light signal into electrical signal. The electrical signal amplitude is extremely low. Thus, an amplifier is added directly after the photo detector. To make the signal detectable, an IC OPT101 is used as transimpedance amplifier which can be used not only to amplify but also to convert the current into voltage. Variation in light intensity is due to changes in perfusion in the blood volume. The most recognizable waveform is the photoplethysmograph signal which is synchronized to each heartbeat of the person. The signal from OPT101 contains lots of other undesired frequency components. Thus, an active band-pass filter is needed to remove the undesired signal, leaving the frequency which is desired. The filter's pass band should be in range of 0.07 Hz to 3.38 Hz.

The next block is the NANO DE0 FPGA Board. The analog output from the band pass filter is given to the NANO DE0 FPGA Board. It has a 12-bit Analog Digital Converter (ADC) which is used to convert analog data to digital data. The switching of the 660 nm and 940 nm is controlled by NIOS II soft core processor running on FPGA. It stores the output when either of the LED is switched ON. This data can be calculated to find the concentration of oxy-hemoglobin and de-oxyhemoglobin and hence calculate oxygen saturation and heart rate which is displayed on the LCD.

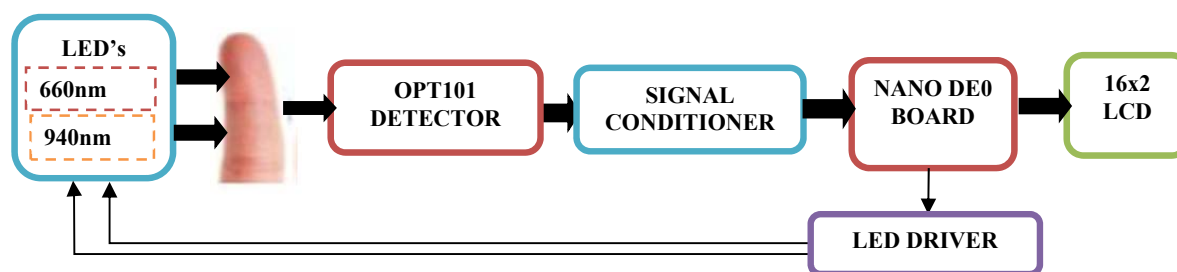

Fig. 1 Block diagram of the Model

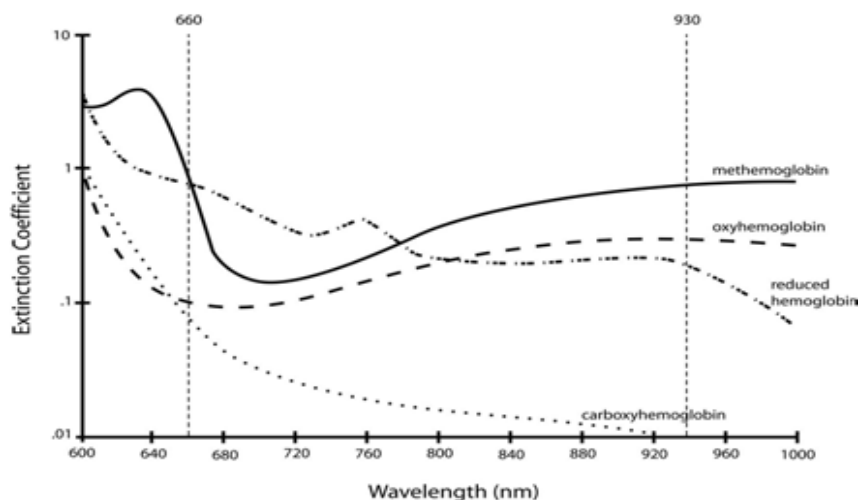

Fig. 2 Light absorbance (Extinction coefficient) vs wavelength [10]

Fig. 2 shows absorption extinction coefficient for different hemoglobin species [10]. Here, we are interested in Oxy-hemoglobin and deoxy-hemoglobin for our calculations to find oxygen saturation.

*A. Principle of Beer-Lambert Law*

The Beer-Lambert Law describes the attenuation of incident light ( $I_0$ ) crossing a material with absorbing properties when an incident beam ( $I_0$ ) enters the sample, the intensity of transmitted light ( $I$ ) decreases exponentially as shown in (1) [4].

$$I = I_0 \cdot e^{-\epsilon(\lambda) \cdot C \cdot L} \quad (1)$$

where  $I$  is the intensity of transmission light;  $I_0$  is the intensity of incident light;  $C$  is the concentration of absorbent, mol (mol);  $L$  is the optical path length in the cm.  $\epsilon$  is the absorptivity (extinction coefficient) of the substance at a specific wavelength,  $\text{mol}^{-1} \text{cm}^{-1}$  (1/mol centimeters) [2].

Absorbance can be calculated using the following equation.

$$A = -\ln \frac{I}{I_0} = \epsilon(\lambda) \cdot C \cdot L \quad (2)$$

where  $A$  is absorbance and  $\lambda$  is wavelength in (2).

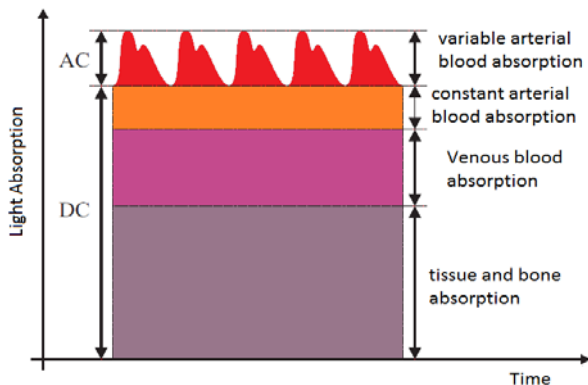

Fig. 3 Light Absorption by different tissues [11]

Fig. 3 shows light absorption by different tissues. The DC value is the light absorption of the tissue, venous blood, and constant arterial blood. The AC value is the light absorption of the variable arterial blood. Then, it analyses the light absorption of two wavelengths to calculate (AC/DC) and then computes the absorption ratio utilizing (3) [11].

$$R = \frac{\frac{I(ac)}{I(dc)}(\text{Red})}{\frac{I(ac)}{I(dc)}(\text{Infrared})} \quad (3)$$

$$R = \frac{(V_{max}(\text{red}) - V_{min}(\text{red})) / V_{dc}(\text{red})}{(V_{max}(\text{infrared}) - V_{min}(\text{infrared})) / V_{dc}(\text{infrared})} \quad (4)$$

Equation (4) is the modified equation to calculate the R Ratio, where  $V_{max}$  is the maximum AC voltage and  $V_{min}$  is the Minimum AC voltage.

Fig. 4 shows the relationship between ratio of absorption between red wavelength and near infrared wavelength.

$$SpO_2\% = 112.5 - R * 25 \quad (5)$$

Equation (5) is the empirical equation to calculate the  $SpO_2$ .

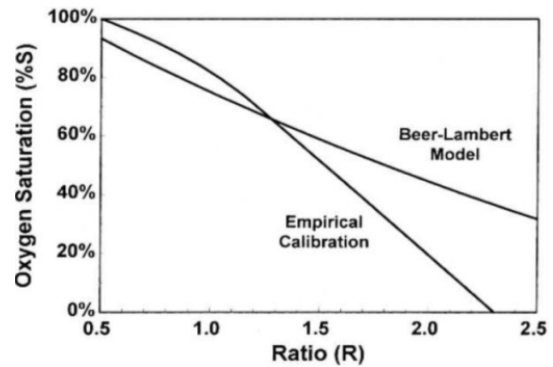

Fig. 4 Relation between R and  $SpO_2$  from Beer-Lambert law [12]

IV. NIOS II INTERACTION

In our design, we have used NIOS II soft-core processor to receive the analog signal for two different wavelengths and to do the necessary calculations to calculate the heart rate and oxygen saturation using empirical formula.

The SOPC components required for building the non-invasive heart rate and oxygen saturation meter is shown below in Fig. 5. The selected components are 32-bit NIOS II CPU, JTAG UART, On chip Memory, Interval Timer, ADC, LCD. After selecting the SOPC components, the entire NIOS II system is generated. The NIOS II processor is interfaced to the on-chip RAM to store the program code and the transmitted signal received from finger probe via ADC.

| Use                                 | Connecti... | Name               | Description                 |
|-------------------------------------|-------------|--------------------|-----------------------------|
| <input checked="" type="checkbox"/> |             | clk                | Clock Source                |
|                                     | →           | clk_in             | Clock Input                 |
|                                     | →           | clk_in_reset       | Reset Input                 |
|                                     | →           | clk                | Clock Output                |
|                                     | →           | clk_reset          | Reset Output                |
| <input checked="" type="checkbox"/> |             | cpu                | Nios II Processor           |
| <input checked="" type="checkbox"/> |             | jtag_uart          | JTAG UART                   |
| <input checked="" type="checkbox"/> |             | adc                | DE0-Nano ADC Controller     |
|                                     | →           | clk                | Clock Input                 |
|                                     | →           | reset              | Reset Input                 |
|                                     | →           | adc_slave          | Avalon Memory Mapped Slave  |
|                                     | →           | external_interface | Conduit                     |
| <input checked="" type="checkbox"/> |             | timer              | Interval Timer              |
|                                     | →           | clk                | Clock Input                 |
|                                     | →           | reset              | Reset Input                 |
|                                     | →           | s1                 | Avalon Memory Mapped Slave  |
| <input checked="" type="checkbox"/> |             | onchip_memory      | On-Chip Memory (RAM or ROM) |
|                                     | →           | clk1               | Clock Input                 |
|                                     | →           | s1                 | Avalon Memory Mapped Slave  |
|                                     | →           | reset1             | Reset Input                 |
| <input checked="" type="checkbox"/> |             | lcd                | 16x2 Character Display      |
|                                     | →           | clock_reset        | Clock Input                 |
|                                     | →           | clock_reset_reset  | Reset Input                 |
|                                     | →           | avalon_lcd_slave   | Avalon Memory Mapped Slave  |
|                                     | →           | external_interface | Conduit                     |
| <input checked="" type="checkbox"/> |             | led_control        | Parallel Port               |

Fig. 5 SOPC Block selected to Build System

The generated system is then brought to Quartus Block diagram file window, and later, the pin mapping is done as shown in Fig. 6. Once the design is compiled, the programming file is ported on Cyclone IVE using USB

blaster. The next step is to run the C code on the NIOS II system to get the expected result. Fig. 7 shows the flowchart for the C code which runs on the NIOS II system.

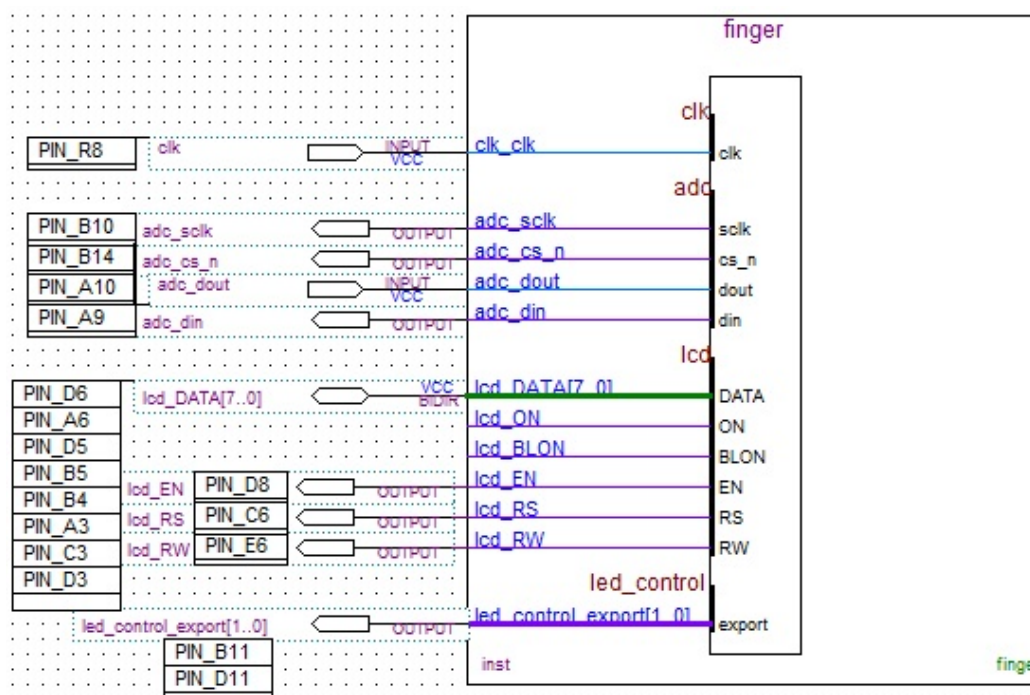

Fig. 6 Altera NIOS II soft-core system interface with Finger probe and LCD

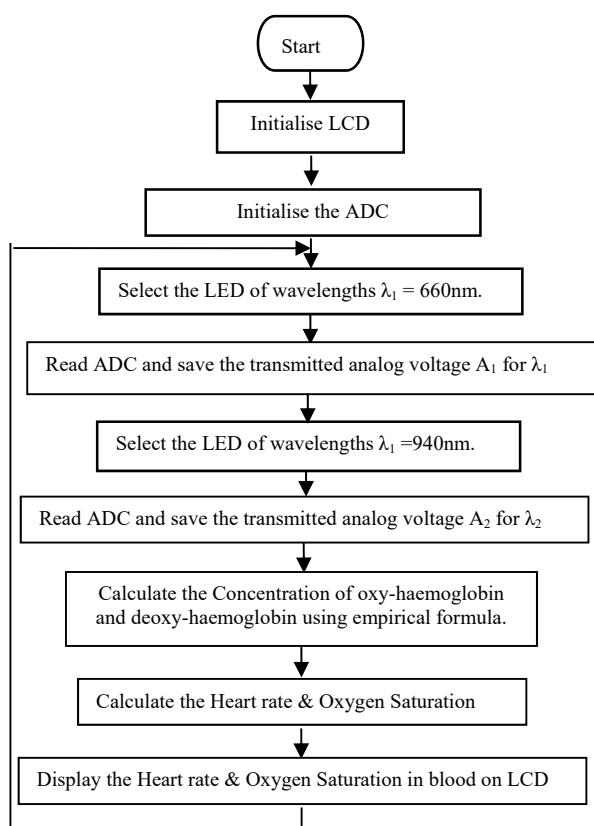

Fig. 7 Flowchart for non-invasive heart rate and oxygen saturation meter

First the LCD is configured as 8-bit data, display on, and cursor on. The ADC is also configured to read the transmitted analog voltages from the finger probe with signal conditioner. The two wavelengths (660 nm /940 nm) will be selected by the soft-core processor one at a time, and the readings for each wavelength will be saved in  $A_1$  to  $A_2$  (absorbance from  $\lambda_1$  to  $\lambda_2$ ). The concentrations of oxy-hemoglobin, deoxyhemoglobin species are calculated using empirical formula equations. Also, heart rate and oxygen saturation are calculated and finally displayed on LCD.

## V. RESULT AND DISCUSSIONS

The Quartus II software was used for building the non-invasive heart rate and oxygen saturation which was downloaded onto NANO DE0 Board. Finally, it was connected to the finger probe with two LED's and a photo detector along with signal conditioner to get the desired heart rate and oxygen saturation for 10 subjects with 50 measurements. It was found accurate with less error when compared with standard Pulse Oximeter. Also, total hemoglobin can be calculated by using appropriate formulas. Further work can be improvised by including more wavelengths to calculate total hemoglobin along with multivariate regressions.

The PPG Signal was observed during each heart beat for two different wavelengths of LED's (660 nm and 940 nm) using Audacity software on PC and also using Digital Storage Oscilloscope.

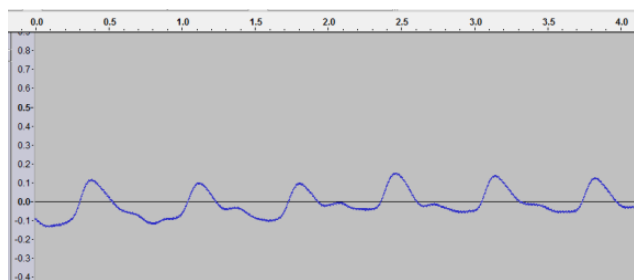

Fig. 8 PPG signals for 660nm LED

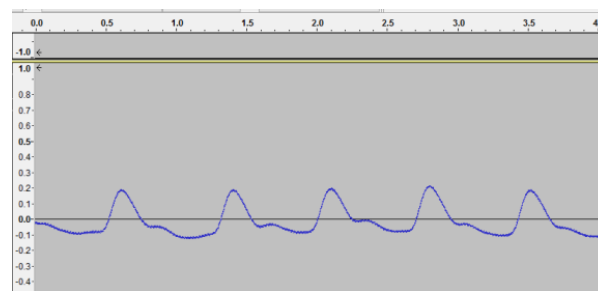

Fig. 9 PPG signals for 940nm LED

TABLE I  
HEART RATE AND OXYGEN SATURATION

| Subject | With finger Red (660 nm) |                      | With finger IR (940 nm) |                      | RatioR | SpO <sub>2</sub> %  | Heart Rate | SpO <sub>2</sub> %                 | Heart Rate |
|---------|--------------------------|----------------------|-------------------------|----------------------|--------|---|------------|------------------------------------|------------|
|         | V <sub>min</sub> (v)     | V <sub>max</sub> (v) | V <sub>min</sub> (v)    | V <sub>max</sub> (v) |        |   |            |                                    |            |
|         |                          |                      |                         |                      |        | <b>Using NIOS II Based Heart Rate &amp; Oxygen Saturation</b> |            | <b>Using Operon Pulse Oximeter</b> |            |
| 1.      | 0.6                      | 1.4                  | 0.8                     | 3.2                  | 0.5    | 99.13   | 76         | 99                                 | 76         |
| 2.      | 0.6                      | 1.55                 | 0.8                     | 3.0                  | 0.576  | 98.10   | 74         | 98                                 | 74         |
| 3.      | 0.5                      | 1.3                  | 0.8                     | 3.0                  | 0.582  | 97.95   | 73         | 97                                 | 74         |
| 4.      | 0.6                      | 1.4                  | 1.0                     | 3.4                  | 0.556  | 98.61   | 76         | 97                                 | 76         |
| 5.      | 0.4                      | 1.1                  | 0.7                     | 2.7                  | 0.613  | 97.18   | 74         | 97                                 | 73         |

Fig. 8 shows that Red LED at 660 nm has a small PPG signal compared to Fig. 9 with IR LED at 940 nm. From the above figure, it shows that more IR light transmitted through finger compared to Red LED.

#### IV. CONCLUSION

The development of a Soft-Core system for heart rate and oxygen saturation was efficiently designed using Altera NIOS II on Nano DE0 Board. The code was written in C language and was loaded into the FPGA for measuring heart rate and oxygen Saturation. Further Work has to be carried out to predict the total hemoglobin using multivariate regressions with less error.

#### REFERENCES

- [1] Mendelson Y, "Pulse Oximetry." Wiley Encyclopedia of Biomedical Engineering (2006): vol. 5. Hoboken,NJ: John Wiley & Sons, Inc. Print.
- [2] Ajith K. G., Bony George, Aravind B. and Martin K. M., "Integration Of Low Cost Spo2 Sensor In A Wearable Monitor," ARPN Journal of Engineering and Applied Sciences, vol.10, September 2015, pp. 7553-7558.
- [3] Esrat Jahan, Tilottoma Barua, Umme Salma, "An Overview on Heart Rate Monitoring and Pulse Oximeter System," *International Journal of Latest Research in Science and Technology*, Vol. 3, Issue 5, September-October 2014, pp.148-152.
- [4] [https://www.howequipmentworks.com/pulse\\_oximeter/](https://www.howequipmentworks.com/pulse_oximeter/) Accessed on 20/04/2017.
- [5] Souvik Das, "The Development of a Microcontroller Based Low Cost Heart Rate Counter for Health Care Systems," *International Journal of Engineering Trends and Technology*, Vol. 4, Issue 2, 2013.
- [6] Chaitali G. Gavhale, Pooja G. Karhale, Komal B. Patil, Priyanka K. Jadhav, Mayuri R. Pankar, "Pulse Oximeter Using Arduino," for *International Journal of Research in Advent Technology (IJRAT)* in "CONVERGENCE 2017", April 2017, pp.169-172.
- [7] S. Chidambara Raja, M. N. Sarath Kumar, P. V. Mohanram, "Development of Pulse Oximeter device for the Continuous Monitoring of Pulse rate and Oxygen Saturation Percentage and its Interfacing with LabVIEW," *International Journal of Engineering and Technology* Volume 4 No. 11, November, 2014, pp.635-642.
- [8] N. Anju Latha1, B. Rama Murthy, L. Suresh, "Development of MSP

- based Pulse oximeter with LabVIEW," *IJSET - International Journal of Innovative Science, Engineering & Technology*, Vol. 2 Issue 4, April 2015.
- [9] Bandana Mallick, Ajit Kumar Patro, "Heart Rate Monitoring System Using Finger Tip Through Arduino And Processing Software," *International Journal of Science, Engineering and Technology Research (IJSETR)*, Volume 5, Issue 1, January 2016, pp.84-89.
- [10] Steven J. Barker, Ph.D., M.D., Jeremy Curry, M.D., Daniel Redford, M.D., Scott Morgan, B.S., "Measurement of Carboxyhaemoglobin and Methaemoglobin by Pulse Oximetry: A Human Volunteer Study," *Anesthesiology* 2006, 105:892-7.
- [11] Toshiyo Tamura, Yuka Maeda, Masaki Sekine and Masaki Yoshida "Wearable Photoplethysmographic Sensors—Past and Present," *Electronics* 2014, 3, pp. 282-302.
- [12] <https://sites.google.com/a/nanoviova.com/www1/technology-expertise/pulse-oximetry> Accessed on 30/06/2017.