

Optimization of Real Time Measured Data Transmission, Given the Amount of Data Transmitted

Michal Kopcek, Tomas Skulavik, Michal Kebisek, Gabriela Krizanova

Abstract—The operation of nuclear power plants involves continuous monitoring of the environment in their area. This monitoring is performed using a complex data acquisition system, which collects status information about the system itself and values of many important physical variables e.g. temperature, humidity, dose rate etc. This paper describes a proposal and optimization of communication that takes place in teledosimetric system between the central control server responsible for the data processing and storing and the decentralized measuring stations, which are measuring the physical variables. Analyses of ongoing communication were performed and consequently the optimization of the system architecture and communication was done.

Keywords—Communication protocol, transmission optimization, data acquisition.

I. INTRODUCTION

THE operation of nuclear power plants involves continuous monitoring of the environment in their area. This monitoring is performed using a complex data acquisition system, which collects status information about the system itself and values of many important physical variables e.g. temperature, humidity, dose rate etc. Furthermore, the observed area is very large. It is therefore a transmission of large amounts of data in real time, which puts high demands on communication channels.

The today's data acquisition system is using Ethernet and radio communication to send the required data to central data acquisition control server. But the central control server communicates with the decentralized data acquisition stations using many different communication protocols depending on the hardware located in the particular decentralized measuring station.

Due to the system complexity, heterogeneous communication protocols and the large amount of transmitted data, the communication failures occur quite often and consequently measured data are lost.

For the above mentioned reasons, it was necessary to proceed to the optimization of measured data transmission and to modification of the related hardware architecture of the system [1].

M. Kopcek is with the Slovak University of Technology in Bratislava, Faculty of Materials Science and Technology in Trnava, Institute of Applied Informatics, Automation and Mathematics, Trnava 91702 Slovak Republic (phone: +421-906-068-711; e-mail: michal.kopcek@stuba.sk).

T. Skulavik, M. Kebisek and G. Krizanova are with the Slovak University of Technology in Bratislava, Faculty of Materials Science and Technology in Trnava, Institute of Applied Informatics, Automation and Mathematics, Trnava 91702 Slovak Republic (e-mail: tomas.skulavik@stuba.sk, michal.kebisek@stuba.sk, gabriela.krizanova@stuba.sk).

II. ARCHITECTURE OF AN EXISTING SYSTEM

Teledosimetric system (TDS) consists of the central control server station located in the laboratory of radiation monitoring (LRKO), to which the information is being gathered from decentralized measuring stations. The task of the TDS is to continuously monitor gamma radiation dose rate, activity concentration of aerosols, activity concentration of radioiodine and additional technology status data. Another task of the TDS is to display the measured values to the service staff on the following posts:

- TDS control room in LRKO,
- radiation safety technic workplace,
- shift charge engineer workplace,
- main control room,
- crises and coordination center,
- emergency center,
- and others.

There are 24 decentralized measuring stations in total, which are deployed in 3 areas:

- 5 stations – area within the power plant (PP),
- 15 stations – area at a distance of 3-6 km from the PP,
- 4 stations - area at a distance of 6-15 km from the PP.

Radiotelemetric base assembly is designed for controlling the subordinate stations spreaded around the PP area.

Computer network is formed by a standard local area network, which also includes LRKO.

The central control server performs the following tasks:

- to control the sequence of collected data from the telemetric network located within the PP and its surroundings,
- to convert the values obtained from the individual detection systems to physical quantities,
- to archive the values and compile the necessary reports,
- to monitor minimum and maximum allowed values,
- to ensure the transmission of measured values to specific workplaces, etc.

A. System Structure

The current structure of the teledosimetric system is shown in Fig. 1. The TDS RP is the control server of the whole system and is responsible for the data acquisition from the measuring stations, data backup and data distribution to another TDS processes. The computers GW V1 and GW V2 ensure the communication with devices for monitoring of chimneys, wastewater and hermetic zone. There is currently no data backup made on these devices, which leads to data loss during communication failures.

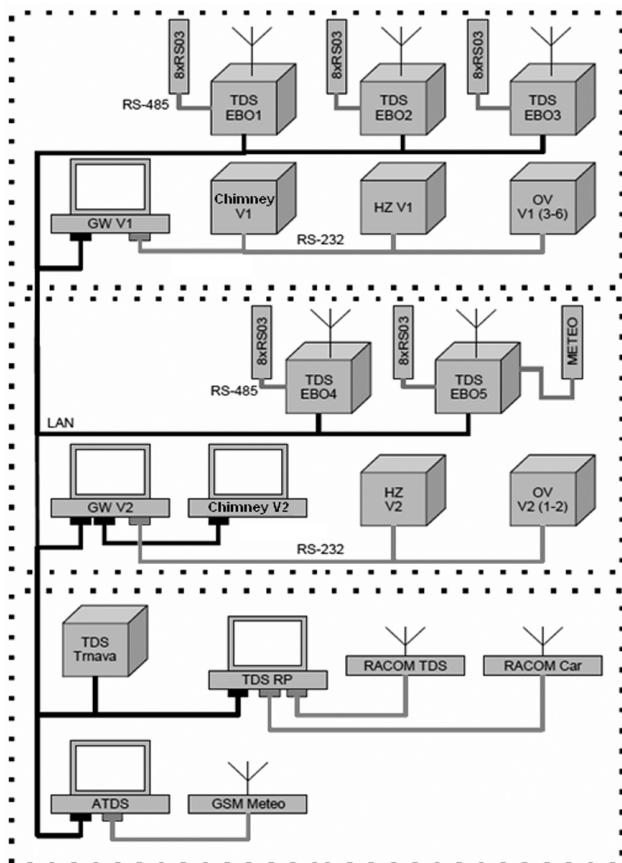

Fig. 1 Today's structure of the teledosimetric system

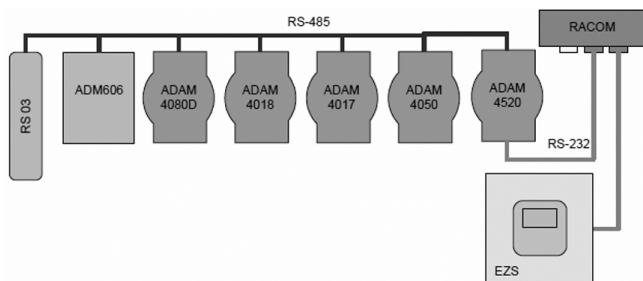

Fig. 2 Hardware architecture of decentralized measuring stations with radio based transmission

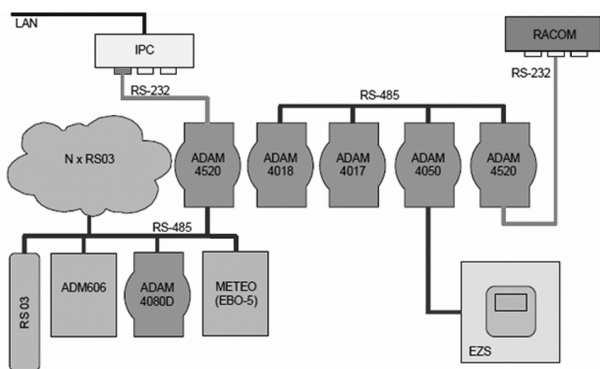

Fig. 3 Hardware architecture of decentralized measuring stations with Ethernet based transmission

The hardware structure of decentralized measuring stations connected to TDS using radiomodems is shown in Fig. 2. There are 18 such stations in the system.

The hardware structure of decentralized measuring stations connected to TDS using LAN is shown in Fig. 3. There are 5 such stations in the system.

The complexity of the whole system is obvious from the above described architecture.

III. COMMUNICATION PROTOCOLS

Communication protocols could be simply divided into a few groups according to the hardware used.

A. Probe RS03

The probe RS03 (BITT technology) is used for measuring the dose rate. Wide measuring range allows recognizing minor changes of the natural radioactivity of the area, as well as measurement of high dose rate, which could cause human deaths already after half hour radiation time.

The probe uses RS485 or RS232 communication interface. The data transmission is performed according to a fixed protocol in messages (blocks) in both directions of communication [2].

The structure of the message is as follows:

- header,
- data,
- checksum.

The message may contain one or more packets. It may be that the message is so long that it cannot be sent in one block. Therefore, the message is divided into packets. The packet structure is shown in Fig. 4.

Device type	Device number	Message type	Packet counter	Flag	Length	Data
-------------	---------------	--------------	----------------	------	--------	------

Fig. 4 Communication packet structure of probe RS03

B. Monitoring Device ADM-606

The ADM-606M is a microprocessor controlled device for monitoring of radiation with automatic adjustment of digital / analog display which provides high accuracy and trending of results. It has RS-232 and RS-485 ports for connection to the host computer or terminal. Most of the information and functions contained on the front panel is also accessible by the serial communication protocol. The serial communication protocol of ADM-606 uses 4 basic commands, each with different optional parameters [3], [4].

C. Data Acquisition Modules ADAM 4000 Series

The devices ADAM 4000 are a set of intelligent sensor-computer interfaces with built-in microprocessor. They provide signal conditioning, isolation, restriction, A/D and D/A conversion, data comparison, and features of digital communications. They can be also operated remotely using simple commands in ASCII format transmitted through the RS-485 protocol. The command set of each of modules consists of approximately 10 commands. The command set of the input modules is more extensive due to the inclusion of

alarm functions [5], [6].

TDS architecture uses following ADAM modules:

- 1) ADAM 4520 - RS-232 to RS-422/RS-485 converter.
- 2) ADAM 4080D – frequency counter.
- 3) ADAM 4017 – 16 bit A/D converter input module.
- 4) ADAM 4018 – 16 bit A/D converter with 8 inputs.
- 5) ADAM 4050 – I/O module with 7 inputs and 8 outputs.

For the sake of preventing communication problems between modules trying to send data at the same time all communication is controlled by a host computer. Communication is initialized by a host computer using a protocol request / response. Fig. 5 shows the basic structure of the communication packet of ADAM modules.

Delimiter	Address	Command	Data	Checksum	LF+CR
-----------	---------	---------	------	----------	-------

Fig. 5 Communication packet structure of ADAM modules

D. Radio Modem MR400

The radio communication is in the TDS provided by radiomodems MR400 (RACOM). They are based on the MORSE system (MOdems for Radio-based SystEms). The modems support a very wide range of communication protocols and they can be used to build complex networks, they provide data retransmission (forwarding) and routing table settings. Each modem has a unique identification number that has in communication the same function as the computer IP address in a computer network [7], [8].

A full-duplex protocol MARS-A is used within the TDS with 32-bit address with error detection and correction. Fig. 6 shows the basic structure of MARS-A protocol communication packet.

Device type	Device number	Command type	Packet counter	Flag	Length	Data
-------------	---------------	--------------	----------------	------	--------	------

Fig. 6 Communication packet structure of MARS-A protocol

IV. DETERMINATION OF QUANTITY OF TRANSMITTED DATA

In order to optimize communication in the system, the following equations were derived for determining the quantity of transmitted data.

A. Percentage of the Useful Data in the Packet

$$U_P = \frac{L_{UP}}{L_{CP}} * 100\% \quad (1)$$

where:

- L_{UP} – the size of useful data in each packet (Byte)
- L_{CP} – the total size of each packet (Byte)

B. Percentage of the Useful Data with Respect to the Data Communicated:

$$U_K = \frac{CL_{UP}}{CL_{CP}} * 100\% \quad (2)$$

where:

- CL_{UP} – the size of useful data in total communicated packets (Byte)

CL_{CP} – the total size of communicated packets (Byte)

$$\begin{aligned} CL_{UP} &= L_{UP_P} + L_{UP_O} \\ CL_{CP} &= L_{CP_P} + L_{CP_O} \end{aligned} \quad (3)$$

C. Percentage of Relevant Data within the Useful Amount of Data Transmitted in Group of Packets:

$$R_B = \frac{L_{RB}}{L_{UB}} * 100\% \quad (4)$$

where:

- L_{RB} – the size of relevant data in each group of packets (Byte)

L_{UB} - the size of useful data in each group of packets (Byte)

D. Percentage of Relevant Data from the Total Amount of Transmitted Data:

1) Relevant quantity:

$$R_{OS} = \frac{CL_{ROS}}{CL_{COS}} * 100\% \quad (5)$$

where:

- CL_{ROS} – the total size of relevant data in each group of packets (Byte)

CL_{COS} – the total size of data communicated in each group of packets (Byte)

$$\begin{aligned} CL_{ROS} &= L_{RB_ADAM} + L_{RB_RS03} + L_{RB_ADM606} \\ CL_{COS} &= CL_{CP_ADAM} + CL_{CP_RS03} + CL_{CP_ADM606} \end{aligned} \quad (6)$$

2) Summarization:

$$R_{OS_SUM} = \sum_{i=1}^2 \sum_{j=1}^{N_{i,j}} \frac{N_{i,j} * CL_{ROSi,j}}{N_{i,j} * CL_{COSi,j}} * 100\% \quad (7)$$

where:

- $N_{i,j}$ – the number of stations in group i and subgroup j
- $CL_{ROSi,j}$ – the total size of relevant data in each group of packets of given station configuration (Byte)

$CL_{COSi,j}$ – the total size of data communicated in each group of packets of given station configuration (Byte)

V. ANALYSIS OF ONGOING COMMUNICATION BASED ON COMMUNICATION PROTOCOLS

This part of the presented article is focused on the analysis of the current state of communication, which is ongoing within the implemented architecture of the system between the central control server and the data acquisition devices (decentralized measurement stations).

The total size of each packet is evaluated by the number of characters (1 character = 1 Byte), which are transmitted by a communication channel during the dialogue "Request - Response" ongoing between the server and the measurement devices.

The size of useful data in each packet is evaluated by the number of characters (Bytes), which represent data demanded by the server for further processing and archiving. These data

are a part of the communication packet.

A. Probe RS03

Within the performed analysis of real ongoing communication a data set containing communication packets sent (request) and received (response) by the server was captured (a sample could be seen in Appendix). Results of evaluation of packets sizes and percentage of useful data in the packet are summarized in Tables I to IV. The data in Tables III and IV were calculated by using (1) and (2).

TABLE I
 THE TOTAL SIZE OF EACH PACKET

Packet	Status Data (Byte)	Measured Data (Byte)
Request	14	14
Response	55	56

TABLE II
 THE SIZE OF THE USEFUL DATA IN EACH PACKET

Packet	Status Data (Byte)	Measured Data (Byte)
Request	0	0
Response	41	42

TABLE III
 THE PERCENTAGE OF THE USEFUL DATA IN THE PACKET

Packet	Status Data (%)	Measured Data (%)
Request	0	0
Response	74.54	75.00

TABLE IV
 PERCENTAGE OF THE USEFUL DATA WITH RESPECT TO THE DATA COMMUNICATED

Type of Data	Status Data	Measured Data
The Amount of Useful Data (%)	59.42	60.00

B. Monitoring Device ADM-606

The length of both types of communication packets (request, response) is in this case variable and depends on communication parameters. For this reasons, it is impossible to exactly determine the size of communication packets. Therefore the evaluation is limited to those packets that have been captured in real ongoing communication, because it can be assumed that the structure of queried information does not change during the operation of the system.

Results of evaluation of packets sizes and percentage of useful data in the packet are summarized in Tables V to VIII. Measured and status data are transmitted in the same communication packet in this case. The data in Tables VII and VIII were calculated by using (1) and (2).

TABLE V
 THE TOTAL SIZE OF EACH PACKET

Packet	Status and Measured Data (Byte)
Request	21
Response	73

TABLE VI
 THE SIZE OF THE USEFUL DATA IN EACH PACKET

Packet	Status and Measured Data (Byte)
Request	0
Response	46

TABLE VII
 THE PERCENTAGE OF THE USEFUL DATA IN THE PACKET

Packet	Status and Measured Data (%)
Request	0
Response	63.01

TABLE VIII
 PERCENTAGE OF THE USEFUL DATA WITH RESPECT TO THE DATA COMMUNICATED

Type of Data	Status and Measured Data
The Amount of Useful Data (%)	48.93

C. Data Acquisition Modules ADAM 4000 Series

The length of both types of communication packets (request, response) is in this case variable and depends on the command sent in request and on the type of addressed module ADAM (4017,4018,4050,4080). For this reasons, it is impossible to exactly determine the size of communication packets. Therefore the evaluation is limited to those packets that have been captured in real ongoing communication, because it can be assumed that the structure of queried information does not change during the operation of the system. Results of evaluation of packets sizes and percentage of useful data in the packet are summarized in Tables IX to XII. Only measured data are transmitted in this case.

The data in Tables XI and XII were calculated by using (1) and (2).

TABLE IX
 THE TOTAL SIZE OF EACH PACKET

Packet	Measured Data (Byte)
Request	5
Response	9

TABLE X
 THE SIZE OF THE USEFUL DATA IN EACH PACKET

Packet	Measured Data (Byte)
Request	0
Response	7

TABLE XI
 THE PERCENTAGE OF THE USEFUL DATA IN THE PACKET

Packet	Status and Measured Data (%)
Request	0
Response	77.77

TABLE XII
 PERCENTAGE OF THE USEFUL DATA WITH RESPECT TO THE DATA COMMUNICATED

Type of Data	Status and Measured Data
The Amount of Useful Data (%)	50.00

VI. ANALYSIS OF ONGOING COMMUNICATION BASED ON COLLECTED PHYSICAL VALUES

This part of the presented article is focused on the analysis of the current state of communication with respect to collected data, which is ongoing within the implemented architecture of the system between the central control server and the data acquisition devices (decentralized measurement stations). The informational content of captured data set differs from the data set used in previous analysis in that that these files do not contain data packets of the type "request", which are sent by the server. Based on the analysis of communication protocols of measuring devices, it is clear that not all of the useful data, which are sent to the central control server, are relevant for the LRKO. This is related to the monitored physical variables.

Based on the analysis of the hardware architecture of the measurement stations, two separate groups of separate configurations are considered according to the structure of involved measurement devices (data acquisition modules and sensors) as follows:

- the 1st configuration group - 5 measurement stations,
- the 2nd configuration group - 18 measurement stations.

Within the performed analysis of queried useful data, a data set containing communication packets received (packets of the response type) by the server was captured.

A. Response Data of the First Configuration Group

Similarities were identified in the captured data sets in the structure of the queried data in a group of packets (data package). So, the 1st configuration group is further divided into two subgroups. The data sets within separate subgroups show difference only in currently measured values. Therefore only one representative package of queried data has been evaluated for each subgroup.

Results of evaluation of percentage of relevant data within the useful amount of data transmitted in a package (data collected during one acquisition period) were calculated by using (4) and are summarized in Tables XIII and XIV.

TABLE XIII
 THE PERCENTAGE OF THE RELEVANT DATA R_B FOR THE FIRST CONFIGURATION SUBGROUP (3 ACQUISITION STATIONS)

Type of Data in Group of Packets	Amount of Data (Byte)
Useful	27
Relevant	23
Relevant Amount (%)	85.18

TABLE XIV
 THE PERCENTAGE OF THE RELEVANT DATA R_B FOR THE SECOND CONFIGURATION SUBGROUP (2 ACQUISITION STATIONS)

Type of Data in Group of Packets	Amount of Data (Byte)
Useful	157
Relevant	79
Relevant Amount (%)	50.31

B. Response Data of the Second Configuration Group

Similarities were identified in the captured data sets in the structure of the queried data in a group of packets (data package). So, the 2nd configuration group is further divided

into two subgroups. The data sets within separate subgroups show difference only in currently measured values. Therefore only one representative package of queried data has been evaluated for each subgroup.

Results of evaluation of percentage of relevant data within the useful amount of data transmitted in a package (data collected during one acquisition period) were obtained by using (4) and are summarized in Tables XV and XVI.

TABLE XV
 THE PERCENTAGE OF THE RELEVANT DATA R_B FOR THE FIRST CONFIGURATION SUBGROUP (14 ACQUISITION STATIONS)

Type of Data in Group of Packets	Amount of Data (Byte)
Useful	157
Relevant	79
Relevant Amount (%)	50.31

TABLE XVI
 THE PERCENTAGE OF THE RELEVANT DATA R_B FOR THE SECOND CONFIGURATION SUBGROUP (2 ACQUISITION STATIONS)

Type of Data in Group of Packets	Amount of Data (Byte)
Useful	182
Relevant	65
Relevant Amount (%)	35.71

C. Quantitative Evaluation of the Total Amount of the Relevant Data within Ongoing Communication

The percentage of the amount of relevant data from the total amount of data transferred was determined. This metric appears to be most suitable for quantitative assessment of optimization, which is solved in the next section of this paper.

The results shown in Table XVII were calculated by using (5) and (7).

TABLE XVII
 THE PERCENTAGE OF THE RELEVANT DATA R_{OS} AND R_{OS_SUM} FOR THE DATA TRANSMITTED IN TOTAL

Configuration (Group/Subgroup)	Number of Stations	R_{OS} (%)
1 / 1	3	46.00
1 / 2	2	25.65
2 / 1	14	25.65
2 / 2	4	25.65
R_{OS_SUM} (%)	23	26.13

VII. PROPOSAL OF OPTIMIZED HARDWARE ARCHITECTURE AND COMMUNICATION PROTOCOL

The analysis shows, that communication within the TDS is currently overloaded by the large amount of redundant information. This fact is proven by the calculated percentage of useful and relevant data. The individual measuring stations consist of devices, which are using their own communication protocols that are proprietary in some cases. Because of this, it is impossible to optimize the communication protocols themselves and with the current hardware architecture neither to optimize the communication sessions. Therefore, it was recommended to add an IPC to each measuring station. The block diagram of the proposed architecture is shown in Fig. 7. Such a modification enables to decentralize some central control server functions and to optimize ongoing

communication between the central control server and decentralized measuring stations.

On the one hand will be the added IPC responsible for collecting of data from different measurement devices located in one measuring station and on the other for ensuring the communication with the central control server. The proposed architecture enables to implement new optimized communication protocol through which the communication between the IPC and the server will be provided.

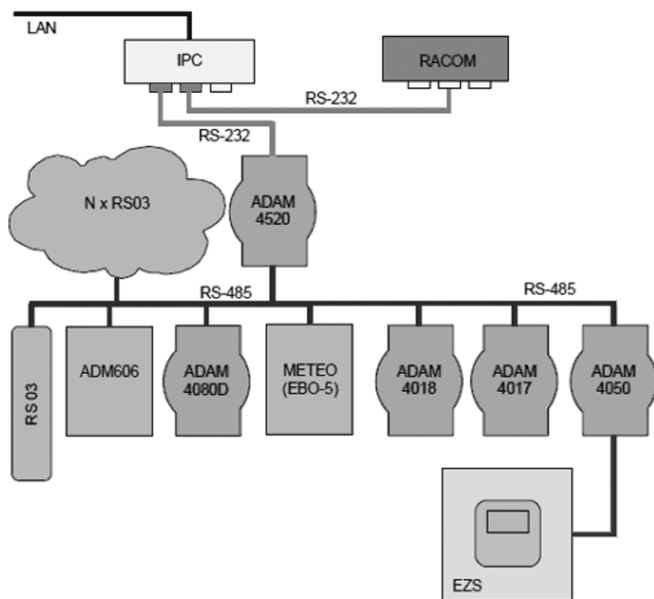

Fig. 7 The principal block diagram of the proposed architecture

From the analysis of the current state of the system results that, given the nature of the transmitted data, the ongoing communication could be divided into two types, namely [9]:

- cyclical – for the transmission of periodically measured data,
- acyclical - for the transmission of configuration, status and control data.

A. Cyclical Communication

This method of communication will be used for the transmission of periodically measured data i.e. the values of the monitored process variables. Analysis shows that all of the measured variables could be declared using the REAL and BOOL data types. Based on this, a new format of communication packet was designed with a length of 5 bytes. All transmitted bytes are binary encoded. The density of the transmitted information, i.e. the percentage of useful and relevant data in the ongoing communication, is increased in this way.

TABLE XVIII

THE PERCENTAGE OF THE RELEVANT DATA R_{OS} AND R_{OS_SUM} FOR THE DATA TRANSMITTED IN TOTAL BY THE OPTIMIZED COMMUNICATION PROTOCOL

Configuration (Group/Subgroup)	Number of Stations	Number of Variables	R_{OS} (%)
1 / 1	3	4	80.00
1 / 2	2	15	80.00
2 / 1	14	15	80.00
2 / 2	4	20	80.00
R_{OS_SUM} (%)	23	54	80.00

B. Acyclical Communication

This method of communication will be used for the transmission of such data, which are not necessary to measure and collect periodically, namely these three data groups:

- alarms,
- configuration data,
- historical data.

C. Evaluation of the Estimate of the Percentage of Transmitted Relevant Data by the Optimized Protocol

In order to evaluate the benefits of the proposed optimization of the communication protocol, it is necessary to provide some of the quantitative indicators on which the proposed solution is compared with the existing one. Within the estimation of the percentage of transmitted useful data the decomposition of the optimized communication protocol to cyclical and acyclical communication will remained as in the proposal.

- Cyclical Communication

The total length of the proposed optimized packet is 5 Bytes, of which 4 Bytes are the relevant data. Since the same format of the communication packet is used to transfer of all variables, the calculated value of the percentage of relevant data is also the same. The results shown in Table XVIII were calculated by using (5) and (7).

- Acyclical Communication

In this method of communication was not designed specific format of a communication packet, therefore it is not possible to use any of the metrics described in this paper and quantify the specific value for comparison. However, the proposal makes it clear that the acyclical communication will be used only in very special cases. While in existing system are e.g. alarm messages transmitted cyclically, the proposed solution assumes event triggered transmission of this kind of data. Therefore, it is obvious that the proposed method of communication will play a significant role in minimizing the total amount of data transferred.

D. Comparison and Evaluation of Communication Protocol Optimization

The performed quantitative analysis of the proposed protocol proves that the optimization of communication ongoing between the central control server and the decentralized measuring stations will result in a notable reduction in the amount of data transmitted and in significant increase in the efficiency of communication as shows the

comparison of calculated parameters in Table XIX.

TABLE XIX
 COMPARISON OF THE PERCENTAGE OF THE RELEVANT DATA R_{OS} AND R_{OS_SUM}
 FOR THE DATA TRANSMITTED IN TOTAL

Configuration (Group/Subgroup)	Non-Optimized R_{OS} (%)	Optimized R_{OS} (%)
1 / 1	46.00	80.00
1 / 2	25.65	80.00
2 / 1	25.65	80.00
2 / 2	25.65	80.00
R_{OS_SUM} (%)	26.13	80.00

The results clearly show the improvement of quantitative indicators by more than 50%, which is not negligible increase in the quality of the entire system.

VIII. CONCLUSION

The proposed slight adaptation of the decentralized measuring station architecture brings the possibility to extend the functionality of the station itself e.g. by implementing data backup functions for the case of communication failures. Thanks to the decomposition of the communication based on the type of included information, the total amount of transmitted data could be significantly decreased. The proposed communication protocol presents an added value and it will contribute to the overall efficiency, safety and reliability of the TDS.

The further work will be focused on the implementation and testing of proposed solutions. Also further possibilities to enhance system features will be investigated. The system will be put into operation after a successful development.

APPENDIX

A sample of captured data set from the ongoing system communication.

```
2012-11-05 07:30:17,044 [3081050512] INFO racom2tty
- ./src/racom2tty.cpp(301) - To: EBO2 Data Out:
&032RSD1L0001F

2012-11-05 07:30:17,625 [3081050512] INFO racom2tty
- ./src/racom2tty.cpp(378) - From: EBO2 Data:
D032DSD1L041 121105 0917 21 *0 *0 092 1700 14.0
+07.050

2012-11-05 07:30:18,144 [3081050512] INFO racom2tty
- ./src/racom2tty.cpp(301) - To: EBO2 Data Out:
&032RDV1L0001A

2012-11-05 07:30:18,849 [3081050512] INFO racom2tty
- ./src/racom2tty.cpp(378) - From: EBO2 Data:
D032DDV1L042 121105 0917 5.300e+00 0000 0479 1.076e-
076C
```

Fig. 8 The sample of captured system communication data set

ACKNOWLEDGMENT

This publication is the result of implementation of the project: "Research of monitoring and evaluation of non-standard conditions in the area of nuclear power plants" (ITMS: 26220220159) supported by the Research & Development Operational Programme funded by the ERDF. The project is co-financed from EU resources.

REFERENCES

- [1] Stengl a.s. Contract research of testing and optimizing the transmission of measured data in real time, given the amount of data transferred between the data acquisition and evaluation center and measurement units. Research report, 2013
- [2] Manual gamma detector RS03/X. Documentation.
- [3] APTEC-NRC. Multi-purpose radiation monitor. <http://www.mgi.co.kr/pdf/Areamonitor.pdf>
- [4] ADM-606/616/606M Series Ratemeter Serial Communications Protocol. Documentation.
- [5] Advantech. ADAM-4510/4510S/4520 Startup Manual. 2005. <http://www.phys.unsw.edu.au/~jl/GATTINO/Manual/manuals/ADAM4520.pdf>
- [6] Advantech. ADAM 4000 Data Acquisition Modules User's Manual. <http://www.uiam.mtf.stuba.sk/predmety/tpar/ADAM4000/ADAM-4000_manual_V17.pdf>
- [7] Racom s.r.o. Protocol MARS-A for MORSE (MARS rev.4). 2008.
- [8] Racom s.r.o. Introduction to system MORSE. 2009.
- [9] M. Franekova, F. Kallay, P. Peniak, P. Vestenicky, Communication security of industrial networks: in Slovak, Komunikačná bezpečnosť priemyselných sietí, Monography, EDIS ŽU, Žilina 2007, ISBN 978-80-8070-715-6.