

Reliability Verification of the Performance Evaluation of Multiphase Pump

Joon-Hyung Kim, Him-Chan Lee, Jin-Hyuk Kim, Yong-Kab Lee, Young-Seok Choi

Abstract—The crude oil in an oil well exists in various phases such as gas, seawater, and sand, as well as oil. Therefore, a phase separator is needed at the front of a single-phase pump for pressurization and transfer. On the other hand, the application of a multiphase pump can provide such advantages as simplification of the equipment structure and cost savings, because there is no need for a phase separation process. Therefore, the crude oil transfer method using a multiphase pump is being applied to recently developed oil wells. Due to this increase in demand, technical demands for the development of multiphase pumps are sharply increasing, but the progress of research into related technologies is insufficient, due to the nature of multiphase pumps that require high levels of skills. This study was conducted to verify the reliability of pump performance evaluation using numerical analysis, which is the basis of the development of a multiphase pump. For this study, a model was designed by selecting the specifications of this study. The performance of the designed model was evaluated through numerical analysis and experiment. The results of the performance evaluation were compared to verify the reliability of the result using numerical analysis.

Keywords—Multiphase pump, Numerical analysis, Experiment, Performance evaluation, Reliability verification.

I. INTRODUCTION

DUE to the exhaustion of land resources, interest in offshore resources is growing day by day. Consequently, demand in the offshore plant industry is increasing. Offshore plants use production equipment installed in the sea or on the seabed for capturing marine resources, and this equipment's application is more difficult than it is in plants where the equipment is installed in the ground. As a result, high levels of technical skills are required to develop equipment, and numerous studies have been conducted on this subject [1]-[5].

Multiphase pumps for crude oil transfer are core equipment in offshore plant areas designed for well development. The high pressure inside a well allows the transfer of crude oil just by internal pressure, but production can be increased by applying a pump for crude oil transfer. The internal pressure of wells also decreases as the crude oil is transferred, and the production can be maintained by applying a crude oil transfer pump.

Joon-Hyung Kim is with the Department of Mechanical Engineering, Hanyang Univ., Seoul 133-791, Rep. of Korea (phone: +82-41-589-8347; fax: +82-41-589-8330; e-mail: kjh82@kitech.re.kr).

Him-Chan Lee is with the Department of Mechanical Engineering, Hanyang Univ., Seoul 133-791, Rep. of Korea (e-mail: himchan1123@kitech.re.kr).

Jin-Hyuk Kim is with the Thermal & Fluid System R&BD Group, KITECH, 89 Yangdaegiro-gil, Cheonan-si, Rep. of Korea (e-mail: jinhyuk@kitech.re.kr).

Yong-Kab Lee is with the ANFLUX CO., Ltd., Seoul 133-791, Rep. of Korea (e-mail: yklee@anflux.com).

Young-Seok Choi is with the Chungcheong Division, KITECH, 89 Yangdaegiro-gil, Cheonan-si, Rep. of Korea (e-mail: yschoi@kitech.re.kr).

In the past, single-phase pumps were used for the transfer of crude oil. As crude oil also contains impurities such as gas, seawater, and sand, in order to apply a single-phase pump, a separator had to be installed to separate these phases of crude oil [6]. However, in applying a multiphase pump for crude oil transfer, the production equipment structure can be simplified, because such preliminary work is unnecessary, leading to savings in production costs. Therefore, multiphase pumps are being applied to most of the recently developed oil wells [7].

Conducting a study on the development of hydraulic devices must be accompanied by accurate performance evaluation. In the past, performance evaluations were mostly performed through experiment. However, interest is rising in performance evaluation by numerical analysis, which has advantages in terms of cost and time. Accordingly, many studies have been conducted to improve the accuracy of predictions using numerical analysis [8], [9]. However, most of these studies were related to the prediction of performance related to single-phase flow. With the rising interest in fluid machines to which multiphase flow is applied, studies in related fields are slowly increasing, but the research into the verification of the reliability of numerical analysis for fluid machines in terms of multiphase flow is still very poor.

In this study, reliability verification with respect to the performance evaluation of multiphase pumps was carried out through numerical analysis. For this purpose, the specifications of the multiphase pump under study were selected, and a model pump in line with these specifications was designed. The performance of the designed model pump was evaluated for single-phase and multiphase flows, through numerical analysis and experiment. Then the performance evaluation results were compared. Based on the comparison and analysis results, reliability verification for the prediction of performance of a multiphase pump was carried out through numerical analysis.

II. DESIGN OF MULTIPHASE PUMP MODEL

A. Selection of Design Specifications

It is difficult to investigate actual models of large hydraulic machines due to issues with respect to the test equipment and other restraints. Therefore, the general practice in the testing of and research into fluid machines is to perform a model test by adjusting the scale ratio. Such a model test can be applied through the following law of similarity:

$$Q_P/Q_r = (n_P/n_r) \times (D_P/D_r)^3 \quad (1)$$

$$H_P/H_r = (n_P/n_r)^2 \times (D_P/D_r)^2 \quad (2)$$

$$P_p/P_r = (\eta_p/\eta_r)^3 \times (D_p/D_r)^5 \times (\eta_p/\eta_r) \quad (3)$$

where Q denotes flow, H denotes water head, P denotes the required power, the subscript p denotes the model prototype, and the subscript r denotes the actual pump.

The multiphase pump that is the object of this study is a large pump that has a large processing flow and a very high pressure performance because it is installed in the deep seabed for oil well development. There are additional issues such as vibration, because a multiphase fluid is applied as a working fluid. Therefore, appropriate specifications for the model test were selected. To select the specifications of the multiphase pump under study, the scale ratio was adjusted by applying the law of similarity to the specifications of a working pump that is actually installed in a well [10]. The specifications of the multiphase pump for this study are shown in Table I.

TABLE I
 DESIGN SPECIFICATIONS

Variables	Values
Q	100 m ³ /h
ΔP	200 kPa (2 bar)
Rotation speed	3600 rpm
Efficiency (at GVF 0 %)	More than 60%
Efficiency (at GVF 20 %)	More than 40%
Stage unit	1 stage

B. Design of the Model Pump

The model pump was designed on the basis of the selected design specifications. For the pump type, the helico-axial type that is applicable to a high processing flow and a high gas volume fraction (GVF) range was selected [11].

The design of the fluid machine was based on the design of the meridian plane, blade angle, and blade thickness profile. The meridian plane is a design element representing the basic shape information and is a determinant factor in the overall performance level. The meridian plane of the model pump in this study was selected through a preliminary study [12].

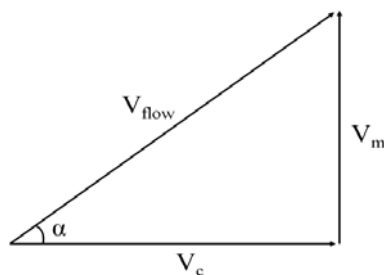

Fig. 1 Velocity triangle theory

The velocity triangle theory, expressed in Fig. 1, is a representative theory for the design of the blade angle of the fluid machine, and it can be also defined by the following equations:

$$V_m = Q/A \quad (4)$$

$$V_c = r \times \omega \quad (5)$$

$$\alpha = \tan^{-1}(V_m/V_c) \quad (6)$$

where V_m is the velocity element of the meridian plane defined by the flow Q and the flow area A, and V_c is the rotational velocity element defined by the radius r and the rotational angle velocity ω . Lastly, the flow angle α is calculated from V_m and V_c . The inlet angle for the impeller and diffuser of the target model pump was designed to agree with the flow angle determined by the velocity triangle theory. The outlet angle and thickness profile were selected on the basis of the internal database, considering the pressure level.

TABLE II
 DESIGN VARIABLES OF THE MODEL PUMP

Variables	Impeller	Diffuser
Number of blades	3 EA	11 EA
Tip clearance	0.5 mm	0 mm
Stage unit	1 stage	1 stage
r_{1_LE}	52.5 mm	59 mm
r_{1_TE}	60.5 mm	53 mm
r_2	75 mm	75 mm
β_{1_h}	10°	17°
β_{1_s}	7°	15°
β_{2_h}	25.5°	90°
β_{2_s}	21°	90°

The design variables of the model pump are shown in Table II. And the 3D shapes of the model pump impeller and diffuser created from the design data are shown in Fig. 2.

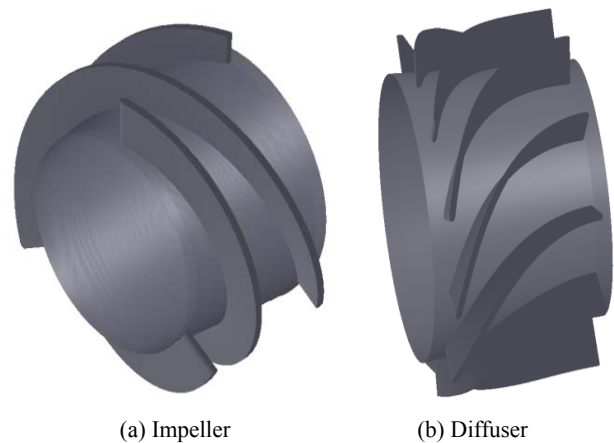

Fig. 2 3D shape of impeller and diffuser for the model pump

III. SINGLE-PHASE PERFORMANCE EVALUATION

A. Performance Evaluation through Numerical Analysis

The performance of the designed model pump for single-phase flow was evaluated through numerical analysis.

For numerical analysis, structured grids for the model pump impeller and diffuser were created using ANSYS TurboGrid ver. 13. For the impeller, two grids were created, depending on the existence of tip clearance, in order to determine the influence of the tip clearance. For the created grid, the impeller with no tip clearance consisted of about 700,000 nodes, the impeller with tip clearance about 750,000 nodes, and the

diffuser about 300,000 nodes. Considering the applied turbulence model, y^+ of the grid was controlled to 2 or lower; the reliability of this grid has been verified through a previous study [12].

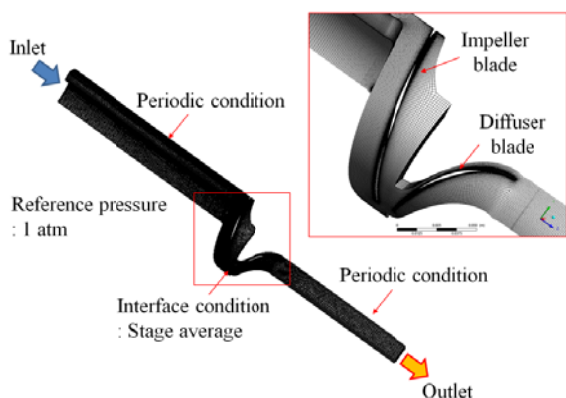
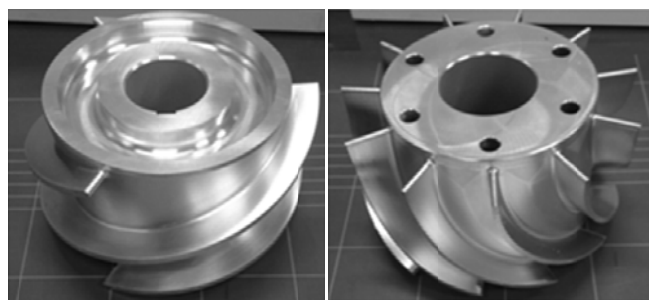

Fig. 3 Numerical analysis conditions for the performance evaluation



(a) Impeller

(b) Diffuser

Fig. 4 Prototype of impeller and diffuser for the model pump

For boundary conditions, as shown in Fig. 3, the flow condition was assigned to the inlet, and the air pressure condition was assigned to the outlet. For the rotation velocity, 3600 rpm was applied, which is the model pump specification. One blade area was analyzed by applying a periodic condition considering the duration of numerical analysis. For the interface condition of the pump impeller and diffuser, the stage average condition was assigned so that averages would be exchanged during operation. For working fluid, water was used for verification by comparison with the experiment results.

The commercial two-dimensional fluid analysis application, ANSYS CFX ver. 13, was used for the numerical analysis. The flow field inside the pump was calculated through the three-dimensional averaged Navier-Stokes equation. The governing equation used in the numerical analysis was discretized by the finite volume method (FVM), and a high-resolution technique with an accuracy of a second or higher order was applied for the discretizing technique. For the turbulence model for turbulence analysis, the Shear Stress Transport (SST) model that has a high accuracy in the prediction of flow separation was applied [13].

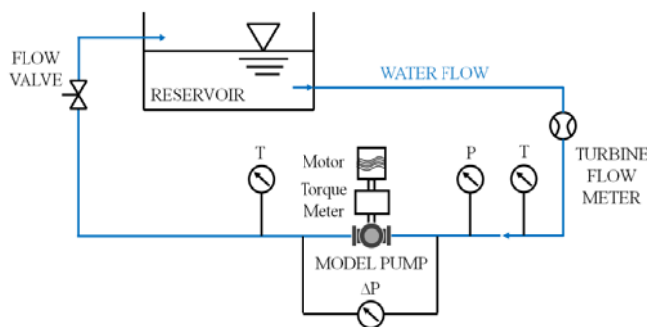
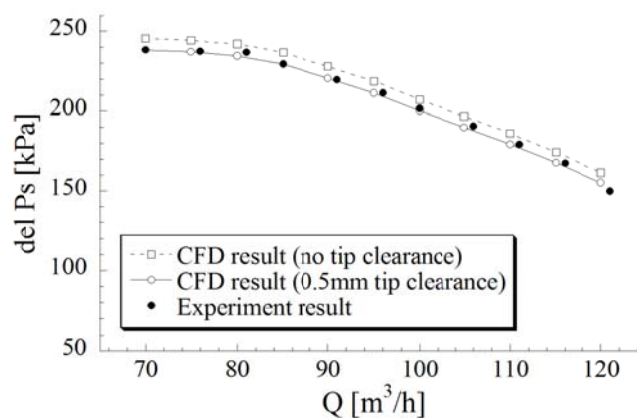
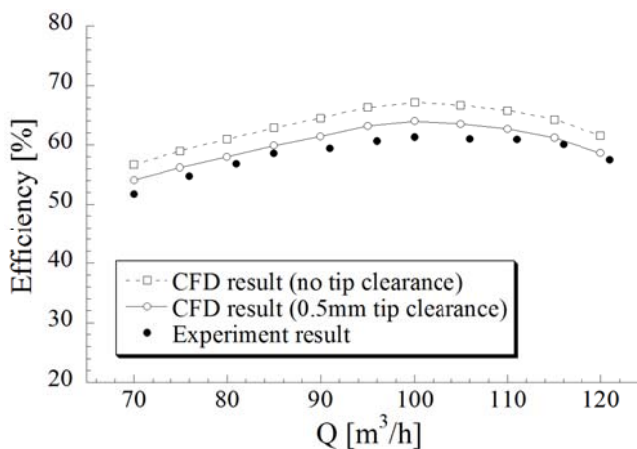

Fig. 5 Schematic diagram of the experiment for a single-phase flow



(a) Result of the pressure difference



(b) Result of the efficiency difference

Fig. 6 Comparison analysis of the performance evaluation (single-phase flow)

B. Performance Evaluation through Experiment

The performance of the designed model pump for single-phase flow was evaluated through experiment.

To conduct experiment, prototypes were produced for the impeller and diffuser of the designed model pump. Aluminum was used for the prototype, and a high degree of precision was achieved through 5-axis milling. The shapes of these prototypes are shown in Fig. 4.

Fig. 5 shows a schematic diagram of the experiment for a single-phase performance evaluation; each test apparatus is

connected by 150A SUS pipe flange. These prototypes were installed in the experiment apparatus. The rotations were regulated at constant speed through an inverter, and the pressure by flow was measured while adjusting the valve at the pump outlet. The model pump axis was connected to a torque meter, and the torque was measured for calculation of efficiency. Water was used as the working fluid.

C. Reliability Verification of the Prediction Results

To verify the reliability of the performance prediction results using numerical analysis, the performance evaluation results were compared with the experiment results. For valid analysis of results, the values measured at the same point were used as the comparison data. The results are shown in Fig. 6.

As can be seen from the results, in the case of pressure difference, the difference in performance between the numerical analysis result including tip clearance and the experiment result is only 0.8%, indicating a very high reliability. In the case of the numerical analysis excluding tip clearance, the performance of the numerical analysis was higher by about 3% compared to the result of the evaluation by experiment. This difference in performance seems to be due to the fact that as a result of excluding tip clearance, the pressure surface becomes greater than the actual blade shape. However, overall performance tendency was very similar to the experiment results.

In the case of pump efficiency, the difference from the experiment results was about 1.9% in the numerical analysis results including tip clearance, and about 5% in the numerical analysis results excluding tip clearance. This performance difference is a little high compared to pressure, but considering the high prediction reliability of pressure, efficiency also seems to indicate a high reliability. Furthermore, the overall efficiency characteristics according to flow are very similar to the experiment results. Therefore, the performance evaluation using the numerical analysis that was applied in this study would be appropriate in the event of a future planned study of the optimal design to improve the performance.

IV. MULTIPHASE PERFORMANCE EVALUATION

A. Performance Evaluation through Numerical Analysis

The performance of the designed model pump for multiphase flow was evaluated through numerical analysis.

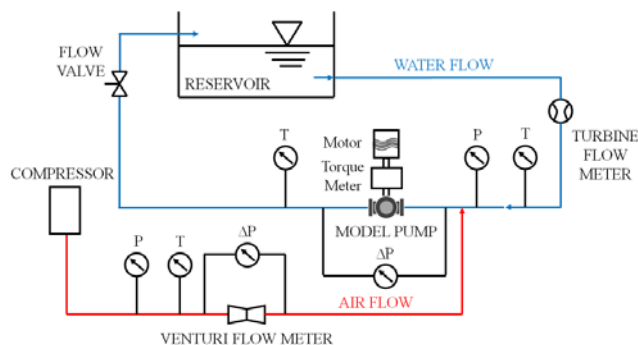
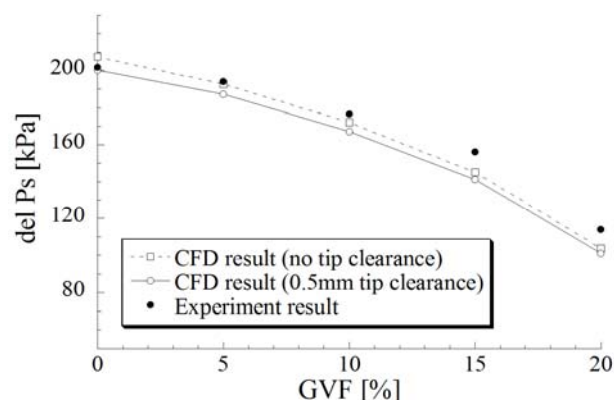
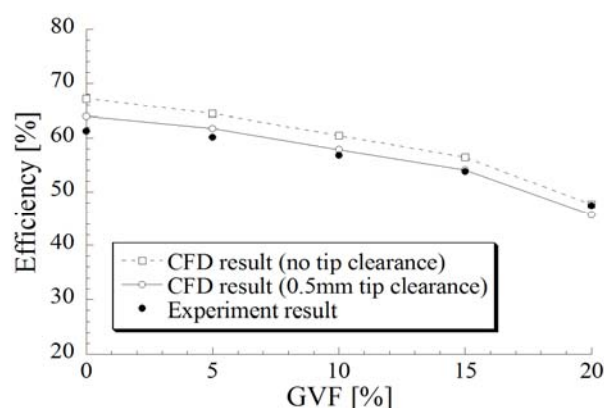

Fig. 7 Schematic diagram of the experiment for a multiphase flow



(a) Result of the pressure difference



(b) Result of the efficiency difference

Fig. 8 Comparison analysis of the performance evaluation (multiphase flow)

The numerical analysis technique for multiphase flow is generally similar to that for the single-phase flow analysis. However, as there are two or more phases in the multiphase flow numerical analysis, a multiphase flow model for interpreting individual and mutual momentums for each phase is required. These multiphase flow models can be divided into homogeneous and inhomogeneous models, depending on the analysis approach. In the case of the homogeneous model, the mixing or separation phenomena inside a multiphase pump cannot be predicted, because it is assumed that the velocity field and the pressure field are identical for every phase. Therefore, the inhomogeneous model that independently calculates the momentum of each phase was applied. The Grace model, which had been used for reliability verification in a previous study, was used as the correlation model for the prediction of drag in the multiphase flow analysis [14]. Water and vapor were applied as working fluids, and the flow was adjusted by applying the concept of GVF (Gas Volume Fraction), which is defined as the volume ratio, as in the following equation:

$$GVF(\%) = (Q_{air} / (Q_{water} + Q_{air})) \times 100 \quad (7)$$

B. Performance Evaluation through Experiment

As water and vapor were applied as the working fluids in this study, a test line was required for air injection to perform the

performance evaluation for the multiphase flow. Thus, the equipment was modified by adding a test line for air injection to the test apparatus that had been used for the single-phase performance evaluation, as shown in the schematic diagram in Fig. 7. A separate compressor was attached for the air supply, and a pressure regulator was installed at the air inlet to control GVF.

C. Reliability Verification of the Prediction Results

The multiphase pump for ocean plants that is a target of this study is a pump designed for the pressurization and transfer of crude oil. Because crude oil contains various gases, a performance drop occurs due to the energy loss of gas. Therefore, an accurate performance prediction according to GVF is essential for a study related to a multiphase pump. To achieve such reliability, the multiphase flow performance that was calculated through numerical analysis was also compared with the experiment results, for verification of reliability. The results are shown in Fig. 8.

As the results show, the pressure loss amount by GVF was a little higher in the numerical analysis result when compared to the experiment result. This difference in the predicted value of the loss amount increased as the GVF increased. At 20% of GVF, an error of about 6.4% appeared when the tip clearance was included, and an error of about 8% when the tip clearance was excluded. The error amount with respect to efficiency was also similar to the error level for the pressure performance. It was about 6.9% when the tip clearance was included and about 8.7% when the tip clearance was excluded. These values were similar to the error levels of the pressure performance. Such error levels appear to be reliable when the very inhomogeneous flow characteristics of the multiphase flow are taken into account. The overall performance drop by GVF is also similar to the experiment results. Therefore, these results could be applicable to a performance evaluation for a multiphase flow. However, additional studies of the multiphase flow analysis model and boundary conditions are required. Through additional studies in the future, the authors plan to perform additional comparisons and verifications.

V. CONCLUSION

In this study, reliability verification with respect to the performance evaluation of a multiphase pump for offshore plants was carried out through numerical analysis.

A model pump was designed for this study, and the performance was evaluated through numerical analysis. To verify the reliability of the numerical analysis results, a prototype of the model pump was prepared, and a comparative analysis was performed for each performance result after performance evaluation through an experiment.

In the case of the performance evaluation for single-phase flow, the difference between the experiment results and the prediction values showed a very high reliability, with a pressure difference of 0.8%. In the case of performance evaluation for multiphase flow, the losses of pressure and efficiency following GVF, which was calculated through numerical analysis, showed a difference of 6.4% and 6.9%, respectively, compared

to the experiment results. These differences are high compared to the results for single-phase flow. However, this result was regarded as reliable, considering the characteristics of complex multiphase flow.

In addition, influence analysis was performed according to tip clearance, which allowed the preparation of standards for related studies.

REFERENCES

- [1] D. Müller-Link, A. Jäschke, Schröder, G., "Multiphase Boosting in Oil and Gas Production," *International Petroleum Technology Conference*, Doha, Qatar, 1997, IPTC 10143.
- [2] A.A. Hamoud, Al-Ghamdi, S.M., "Applications of Multiphase Technologies Optimize Upstream Operations in Saudi Aramco," *SPE Asia Pacific Oil & Gas Conference*, Perth, Australia, 2008, SPE115230.
- [3] Caetano, E.F. Petrobras, "Bormemann Pumpen Cooperation on Multiphase Flow Pumping," *Proceedings of the Offshore Technology Conference*, Houston, USA, 1997, pp. 109-118.
- [4] Hwang, J.H., Min, J.H., Ahn, Y.J., et al., "Optimized Methodology to Build an Integrated Solution to Offshore Topsis Process Engineering," *Proceedings of ISOPE*, Vol (1), 2008, pp. 233~240.
- [5] Shippen, M.E., Scott, S.L., "Multiphase Pumping as an Alternative to Conventional Separation," *PSIG Conference*, Portland, Oregon, SPE Reprint, 2002, No. 58.
- [6] Corless, R.J., "Multiphase Pumps Replace Conventional Heavy Oil Facilities," *Journal of Oil & Gas*, 99(39), 2001, pp. 80~84.
- [7] Mark Finley., "BP Statistical Review of World Energy," *BP Technical Report*, 2013.
- [8] Lu, W.Q., Li, Q.P., Xue, D.S., "Boundary element numerical simulation of gas-liquid two-phase flow in multiphase pump impeller," *International Conference on Computational Methods in Multiphase Flow*, Orlando, 2001, Fl: 13~22.
- [9] Yu, Z.Y., Cao, S.L., Wang, G.Y., "CFD Analysis of the Air-Water Bubbly Flow in a Multiphase Rotodynamic Pump Impeller," *Journal of Engineering Thermophysics*, 28(1), 2007, pp. 46~48.
- [10] Baruzzi, J.O.A., Fagundes Netto, J.R., Caetano, E.F., "Operational Conditions Forecast for the SBMS-500 in the Well 7-MRL- 72D-RJS," *Sol Energy. Technical Partial Report*, 2001.
- [11] Saadawi, H., "Operating Multiphase Helicoaxial Pumps in Series To Develop a Satellite Oil Field in a Remote Desert Location," *SPE Annual Technical Conference*, California, 2007, SPE 109785.
- [12] Kim, J.H., Yoon, J. Y., Choi, Y.S., "Development of Multiphase Pump for Offshore Plant.," *Conference on KSME*, Jeju, KOREA, 2013, pp. 75~76.
- [13] Hellsten A., and Laine S., "Extension of the k-w-SST turbulence models for flows over rough surfaces," *Journal of AIAA*, 1997, 3577.
- [14] Kim, J. H., Yoon, J. Y., Choi, Y.S., "Numerical Study of Multiphase Flow in a Venturi," *Conference on KSME*, Jungsun, KOREA, 2013, Fr17C040.