

Research and Development of Intelligent Cooling Channels Design System

Q. Niu, X. H. Zhou, W. Liu

Abstract—The cooling channels of injection mould play a crucial role in determining the productivity of moulding process and the product quality. It's not a simple task to design high quality cooling channels. In this paper, an intelligent cooling channels design system including automatic layout of cooling channels, interference checking and assembly of accessories is studied. Automatic layout of cooling channels using genetic algorithm is analyzed. Through integrating experience criteria of designing cooling channels, considering the factors such as the mould temperature and interference checking, the automatic layout of cooling channels is implemented. The method of checking interference based on distance constraint algorithm and the function of automatic and continuous assembly of accessories are developed and integrated into the system. Case studies demonstrate the feasibility and practicality of the intelligent design system.

Keywords—Injection mould, cooling channel, automatic layout, interference checking.

I. INTRODUCTION

INJECTION moulding is one of the most important processes in plastics industry. The moulding cycle consists of several stages, such as filling, packing, and cooling. The cooling system of injection mould plays a crucial role in determining the productivity of moulding process and product quality. About 80 % of the cycle time is taken up by the cooling phase, thus efficient cooling increases overall productivity by reducing the cooling time. A cooling system that provides uniform cooling across the entire part ensures product quality by preventing differential shrinkage, internal stresses, and mould release problems [1].

A major concern of cooling channels layout is the feasibility of building cooling system inside the mould without interfering with the other mould components, such as ejector pins, slides, sub-inserts, and so forth. Finding the best location for each cooling channel to optimize the cooling performance of the cooling system and to avoid interference with the other components isn't a simple task [2]. Much research effort has been focused on the analysis of plastic injection mould cooling systems. There are two major directions of current research.

One is from the viewpoint of optimization. Ren and Zhang developed a hybrid approach to solve the cooling system design

considering the location, size and number of cooling channels which combines particle swarm optimization and genetic algorithms to speed up the convergence [3]. Qiao provided a computer-aided approach to achieve a cooling system optimal design based on a hybrid approach combining boundary element method, perturbation-based approach and simulated annealing [4]. Hassan proposed a full three dimensional time-dependent analysis carried out for a mold with cuboids-shape cavity having two different thicknesses. A numerical model by finite volume method was used for the solution of physical model of six horizontal circular channels. The effect of cooling channels position and their form in the heat transfer process through the product and the mold was studied. In the same way, a numerical modeling for a T-mold plastic part with four cooling channels was performed to analyze and optimize transient cooling effect [5], [6].

Another direction is from the viewpoint of design. Li divided process of cooling system design into three major design phases, namely, preliminary design, layout design, and detailed design. The preliminary design phase focused mainly on functional aspect of cooling system, and the cooling effect was the major concern. A feature-based approach to automate the preliminary design was developed [7]. In the layout design phase, the physical realization of the cooling system in the mould structure and the manufacturability should be considered. To automate the layout design, a graph-based technique that captures all feasible designs using a graph structure was developed. The layout design problem was formulated as a graph search problem, and heuristics algorithms were used to guide the searching process [1]. This automatic layout design method was improved later by introducing a configuration space (C-space) technique to capture all of the feasible geometric designs within a given topology, with a genetic algorithm (GA) being employed to perform a more systematic search among all of the feasible designs [2], [8]. However, the above researches were mainly based on theoretical thermodynamics at ideal condition and didn't systemically address the interference issue.

In this paper, an intelligent cooling channels design system is discussed and developed.

II. SYSTEM ARCHITECTURE

The intelligent cooling channels design system includes automatic layout of cooling channels, interference checking, automatic assembly of accessories and continuous assembly of accessories by interactive interfaces. The system architecture is as shown in Fig. 1.

The function of automatic layout of cooling channels is the

Q. Niu is with the National Engineering Research Center of Die and Mold CAD, Shanghai Jiao Tong University, Shanghai, 200030, P.R. China (phone: +86 21 62813430-8235; e-mail: qniu@sjtu.edu.cn).

X.H. Zhou, professor, has been with the Shanghai Jiao Tong University since he received his Ph.D. degree from SJTU in 1995 (e-mail: xhzhou@sjtu.edu.cn).

W. Liu. is with the National Engineering Research Center of Die and Mold CAD, Shanghai Jiao Tong University, Shanghai, 200030, P.R. China (e-mail: liu-wei@sjtu.edu.cn).

core function of the system, which automatically generates cooling channels using genetic algorithm. The function of interference checking is used as the support of automatic layout of cooling channels to check whether cooling channels interfere with other holes. The automatic assembly of accessories is used to generate necessary cooling channel accessories such as cooling channel couplers. The continuous assembly of accessories is used to generate cooling channel accessories that needed to be selected or positioned by interactive interfaces, such as baffles.

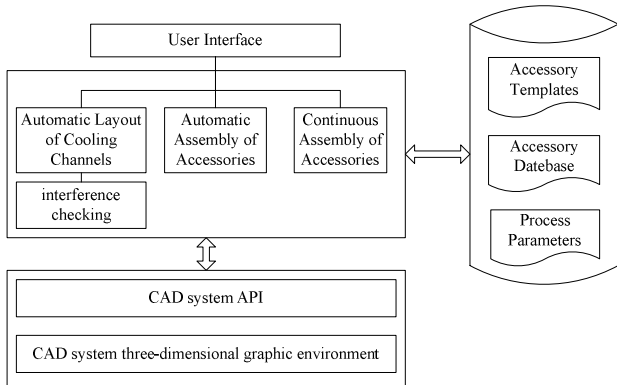

Fig. 1 System architecture

III. AUTOMATIC LAYOUT OF COOLING CHANNELS BASED ON GENETIC ALGORITHM

The criteria of cooling channel design in injection mould:

- (1) The distance between cooling channel and the cavity surface is generally greater than or equal to three times the diameter of cooling channel, so does the distance between two cooling channels. Greater distance reduces cooling effect, whereas shorter distance decreases mould strength.
- (2) Cooling channels should be laid at high temperature region preferentially.
- (3) Interference is not allowed between cooling channels and the other holes in the mould, moreover, a proper distance is needed.

As shown in Fig. 2, given that the cooling channel diameter is d . According to Criteria (1), the minimum distance $grid$ between cooling channels is defined as $3*d$ and the minimum distance between cooling channel and surface of cavity is $grid$ either. The initial axis of cooling channel is limited in a space inside cavity plate where its distance to surface is greater than $grid$. By the method of genetic algorithm, the optimal points are obtained as start point, end point and turn points of each channel. The space is divided into surfaces A, B, C, D plus with the cavity surface and bottom surface, and an internal area M . Surfaces A, B, C, D and area M are regarded as a planning space of cooling channel layout. In the planning space, candidate points are generated by distance $grid$. The generated points on surfaces A, B, C, D are candidates of start point or end point, namely S class point, whereas the generated points in area M are candidates of turn point, namely M class point. The points located in holes should be removed, so the coordinates of points are discrete. The discrete points are numbered continuously,

starting from 1. In this way, the points are not only continuous, but also simply to be operated by genetic operators. Finally, with the method of genetic algorithm, cooling channels are obtained by path planning to the points in the planning space.

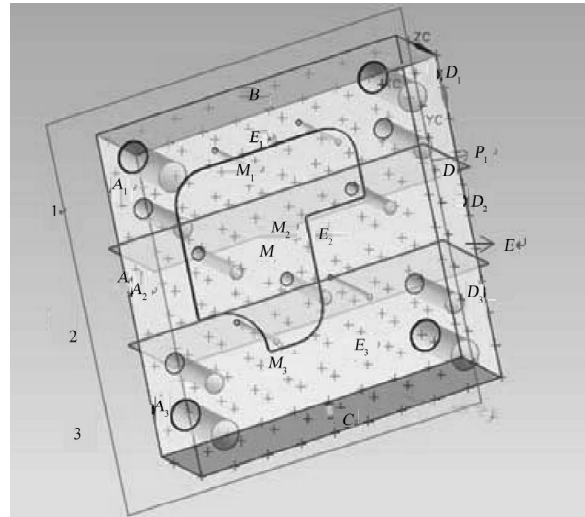

Fig. 2 Method of cooling channels layout

A. Chromosome Encoding

Each cooling channel should have an entry point N_0 and an exit point N_t . As interference objects exist, interference may occur when a cooling channel is generated by a guide line that connecting with point N_0 and point N_t . Therefore, it is necessary to create intermediate points N_j ($0 < j < t$), so cooling channel may turn to avoid the interference object. Thus, the guide line of a cooling channel should be generated by connecting point N_i and N_{i+1} ($0 \leq i < t$). In other words, a complete guide line, namely a chromosome, is composed of $t+1$ genes including entry point, possible turn points and exit point.

Each point in the planning space is regarded as a gene and each gene is expressed by a structure below. The first variable in the structure is a character array str which represents the location attribute of the gene (point), namely, S and M class. The second variable is a character $type$ which represents the gene's function, namely entry point N_0 , turn point N_j and exit point N_t . The third variable is an integer num which represents the index number of genes. The fourth variable is a float array $point$ which represents 3 coordinates (x, y, z) of the gene. The coordinates are used to evaluate a cooling channel, including calculating its length, judging if the channel is perpendicular to the surface of the mould plate and interferes with other holes, etc. The last variable is a float variable $temp$ which records the temperature of the point.

```
struct genotype
{
    char str[2];
    char type;
    int num;
    double point[3];
    double temp;
};
```

If one channel can't meet the demand of cooling, more channels may be arranged. As shown in Fig. 2, a mould plate could be divided into N spaces, indexed by $1, 2, \dots, N$. Accordingly, M class points are divided into M_1, M_2, \dots, M_N and S class points into S_1, S_2, \dots, S_N correspondingly. Therefore, one cooling channel is generated in every independent space by genetic algorithm and N cooling channels are obtained.

B. Initial Population Generating

The initial population composed of a certain number of individuals is the start point of evolutionary computation in genetic algorithm. The number of random paths in the planning space depends on the population size (generally 10 to 100). The larger the size is, the easier the global optimal solution can be found. However, longer search time is needed accordingly.

Cooling channels are not appropriate to locate in the area where holes are dense, as the mould strength is further weakened; meanwhile interferences between holes and cooling channels are more likely to occur. In addition, temperature is also a reference variable in random selection of initial points. The higher the temperature of one point is, the point is more likely to be chosen. The temperature of these points is obtained by simulation software. The high temperature points should be more likely to select while generating initial population.

C. Individual Evaluation and Fitness Function

Individual fitness function directly affects the computational efficiency and optimal results. Evaluation criteria of automatic layout of cooling channels depends on experience, it's difficult to find a fitness function by formulating these engineering experiences. To tackle this problem, fitness function is obtained by combining a series of weights with sub fitness functions formulated from evaluation criterion. The evaluation of cooling channels includes the following factors:

- a) The mould temperature field should be calculated prior to the layout of cooling channels. Assume that the highest temperature is T_{max} and the temperature of each node which on or near a cooling channel is T_i , then the fitness function of the cooling channel is:

$$fit1 = \sum_{i=0}^m \frac{T_i}{m * T_{max}}$$

where, m is the number of grid nodes which consist of the cooling channel.

- b) In order to reduce processing cost, each guide line of a complete channel should be perpendicular to the surface of mould. The connection line of point N_i and point N_{i+1} ($0 \leq i < t$) had better to be parallel or perpendicular to the boundary edge of mould. If a guide line is parallel or perpendicular to the edge of the mould, then $fit2_i = 1/2$, otherwise $fit2_i = 0$. This fitness function of a complete channel is:

$$fit2 = \sum_{i=0}^t fit2_i$$

- c) Each section of a cooling channel can't interfere with holes in the mould, therefore, interference checking algorithm should be used to check it. The fitness function for this principle is $fit3$. If any section of the cooling channel interferes with holes, then $fit3 = 0$, Otherwise $fit3 = 1$.

In conclusion, the complete fitness function for a cooling channel is:

$$fit = (w1 * fit1 + w2 * fit2) * fit3$$

The variables $w1$ and $w2$ in the function are weights, whose value ranges from 0-1. The values of $w1$ and $w2$ should be adjusted according to the specific situations. The fitness function makes the experience which is hard to quantify turn into digital computation by integrating three constraints. When calculate fit , the value of $fit3$ should be calculated first. If $fit3 = 0$, then $fit = 0$, the calculation of fitness function stops.

D. Genetic Operators

Two important genetic operators in genetic algorithm are crossover operator and mutation operator.

By crossover operator, two individuals in the same generation exchange part of their genes in a certain probability to generate new gene combination and obtain more competitive individuals than their parents. Exactly, the higher the probability is, the faster the convergence of the optimal solution is, whereas premature convergence may occur. The value generally ranges from 0.4 to 0.99. For automatic layout of cooling channels, certain constraints should be applied to crossover operator. Given that each chromosome consists of $t+1$ genes. If the number of the same genes n shared by two chromosomes ranges from 1 to t ; a gene for crossover operation is random selected from the rest ($t+1-n$) number of genes. Obviously constrained crossover is more efficient to find the optimal solution than random crossover.

Mutation operator makes changes in genes, expanding the scope of optimization whereas avoiding falling into local optimum. The value generally ranges from 0.0001 to 0.1. In each variation, one gene is selected randomly, then its original serial number num is replaced by a random one in the num collection of this gene type.

IV. OTHER FUNCTIONS OF INTELLIGENT DESIGN SYSTEM

A. Interference Checking

In this paper, distance constraint algorithm is used to check interference. The algorithm checks whether the components are interfered by calculating the minimum distance. If the distance of two components is not greater than zero, they are interfered.

In cooling channels design system, the process of algorithm is as follows. Firstly, offset the model surface of cooling channels outward by minimum allowed clearance between cooling channels and other holes. Secondly, traverse all face of other holes and surface of cooling channels to obtain the parameters of surfaces. Thirdly, calculate the distance between surfaces of holes and cooling channels. Because the minimum allowed clearance is handled by offset in the first step, if the distance is greater than zero, the cooling channel satisfies the

conditions of interference.

B. Automatic and Continuous Assembly of Accessories

Cooling channel accessories, such as cooling channel coupler and baffle, are needed to be assembled into mould. The function of assembly of accessories is used to generate accessory model and assemble into mould automatically or interactively. The flow chart of the function is as shown in Fig. 3.

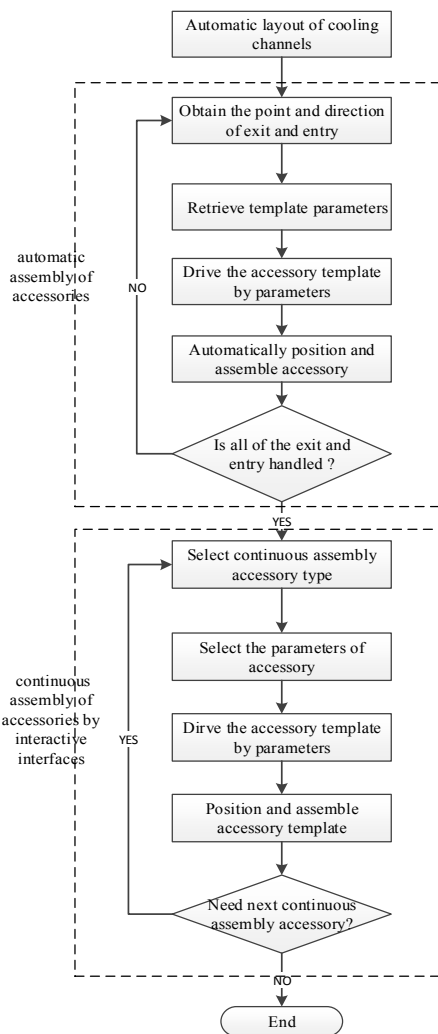

Fig. 3 Flow chart of automatic and continuous assembly

The necessary accessories are assembled by the function of automatic assembly of accessories. Firstly, the point and direction of exit and entry of cooling channels are obtained as the datum of automatic assembly. Secondly, retrieve model parameters from accessory database, according to the diameter of cooling channel. Thirdly, drive the accessory template by retrieved parameters. Finally, position and assemble accessory into the mould automatically.

For the accessories that needed to be selected or positioned by interactive interfaces, the function of continuous assembly of accessories is used. By this function, users can continuously assemble any number of accessories, so the inconvenience of

repeatedly selecting and assembling accessories is solved. Firstly, select continuous assembly accessory type by user interface. Secondly, select the parameters of accessory. Thirdly, drive the accessory template by retrieved parameters. Finally, position and assemble accessory by interactive operation. Users can continuously select and assemble accessories until all needed accessories are assembled.

V. IMPLEMENTATION AND DESIGN EXAMPLE

The system is developed using C++ and is interfaced to the Unigraphics NX CAD/CAM platform.

The size of mould plate is 200mm×200mm×20mm. Two cooling channels with diameter 5mm are laid out. The plate model with cooling channels is as shown in Fig. 4.

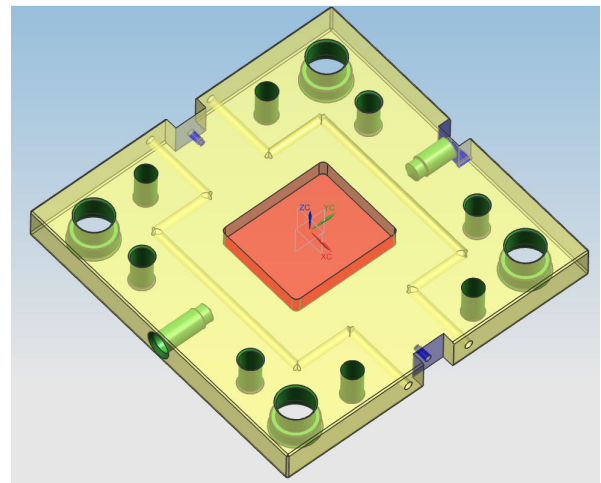

Fig. 4 Mould plate model with cooling channels

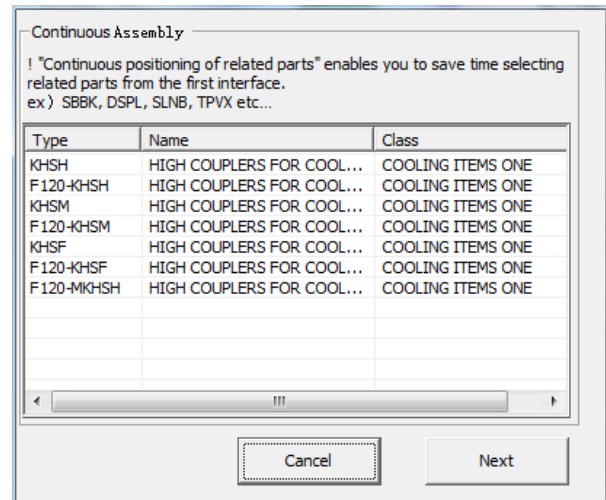

Fig. 5 Continuous assembly of accessories interface

Continuous assembly of accessories interface is as shown in Fig. 5. Select accessory type in the list and click button “next”, then the parameter interface of selected type pops up to select the parameters and assemble selected accessory into mould. Figs. 6 and 7 are the parameter interface and the mould model with cooling channels and accessories.

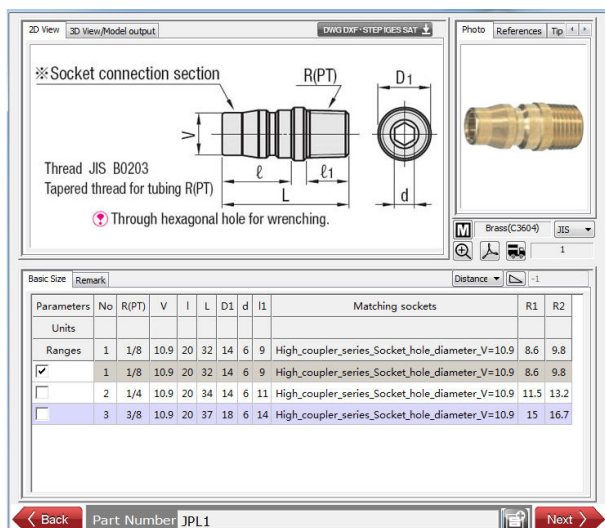

Fig. 6 Parameter interface

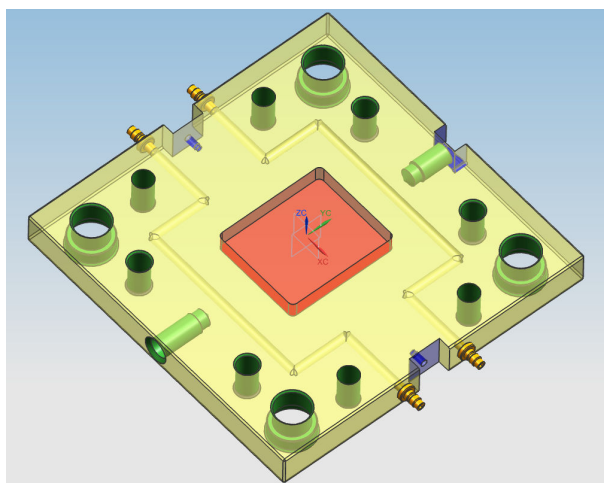

Fig. 7 Mould model with cooling channels and accessories

VI. CONCLUSION

In this paper, we discussed an intelligent cooling channels design system. The system included automatic layout of cooling channels, interference checking, automatic assembly of accessories and continuous assembly of accessories by interactive interfaces. The system has been developed based on Unigraphics NX CAD/CAM platform. It will relieve the mould design engineers of the tedious task, thus, they can concentrate more time and energy on other design tasks.

REFERENCES

- [1] Li C L, Li C G, Mok A C K. Automatic layout design of plastic injection mould cooling system (J). *Computer-Aided Design*, 2005, 37:645-662.
- [2] Li C G, Li C L. Plastic injection mould cooling system design by the configuration space method (J). *Computer-Aided Design*, 2008, 40:335-349
- [3] Li Ren, Wenxiao Zhang. Optimization design of injection mold cooling system based on particle swarm optimization and genetic algorithms. 2011 2nd International Conference on Artificial Intelligence, Management Science and Electronic Commerce, 2011:2232-2235.

- [4] H Qiao. A systematic computer-aided approach to cooling system optimal design in plastic injection molding. *International Journal of Mechanical Sciences*, 2006, 48:430-439.
- [5] Hamdy Hassan, Nicolas Rebnier, et al. 3D study of cooling system effect on the heat transfer during polymer injection molding. *International Journal of Thermal Sciences*, 2010, 49:161-169.
- [6] Hamdy Hassan, Nicolas Regnier, Cedriclebot, et al. Effect of cooling system on the polymer temperature and solidification during injection molding. *Applied Thermal Engineering*, 2009, 29:1786-1791.
- [7] Li C L, Li C G. A feature-based approach to injection mould cooling system design. *Computer-Aided Design*, 2001, 33:1073-1090.
- [8] Li C G, Li C L, Yusheng Liu, et al. A new C-space method to automate the layout design of injection mould cooling system. *Computer-Aided Design*, 2012, 44:811-823.

Q. Niu is a Research Associate in National Engineering Research Center of Die and Mold CAD, Shanghai Jiao Tong University. He received his B.S. (2003) and M.S. (2006) in Mechanical Engineering both from Shandong University, Shan dong, China. He is a PhD candidate in Shanghai Jiao Tong University from 2011. His research interests include intelligent CAD/CAM system, intelligent mould design system and digital manufacturing technology.