

# Comparative Analysis of Two Approaches to Joint Signal Detection, ToA and AoA Estimation in Multi-Element Antenna Arrays

Olesya Bolkhovskaya, Alexey Davydov, Alexander Maltsev

**Abstract**—In this paper two approaches to joint signal detection, time of arrival (ToA) and angle of arrival (AoA) estimation in multi-element antenna array are investigated. Two scenarios were considered: first one, when the waveform of the useful signal is known a priori and, second one, when the waveform of the desired signal is unknown. For first scenario, the antenna array signal processing based on multi-element matched filtering (MF) with the following non-coherent detection scheme and maximum likelihood (ML) parameter estimation blocks is exploited. For second scenario, the signal processing based on the antenna array elements covariance matrix estimation with the following eigenvector analysis and ML parameter estimation blocks is applied. The performance characteristics of both signal processing schemes are thoroughly investigated and compared for different useful signals and noise parameters.

**Keywords**—Antenna array, signal detection, ToA, AoA estimation.

## I. PROBLEM DISCUSSION

**I**n modern radar and communication systems, the problem of joint signal detection and the parameters of signals estimation is quite difficult in the general case.

Usually two main theoretical principle of detection of signals with unknown parameters are used: 1. Method of averaged likelihood ratio, when for solving the detection problem used a likelihood ratio, additionally averaged a priori distributions [1]; 2. The generalized likelihood ratio is then the unknown parameters replaced by their ML estimates on the available samples [2]. However, their implementations when using multi-element antennas is too complicated.

In this work two scenarios of signal processing for detection and ToA and AoA estimation are investigated. Consider narrow-band p-element antenna array with arbitrary spacing elements and assume that useful signal represents a plane wave with unknown AoA and ToA. In this case the detection task for useful signal on the background of spatially and temporally white gaussian noise can be formulated as

O. Bolkhovskaya is with the Department of Bionics and Statistical Radiophysics, Radiophysics Faculty, N.I.Lobachevsky State University, Nizhny Novgorod, 603105, Nizhny Novgorod, Gagarin ave., 23. Russia (e-mail: obol@rf.unn.ru).

A. Davydov is with the Department of Bionics and Statistical Radiophysics, Radiophysics Faculty, N.I.Lobachevsky State University, Nizhny Novgorod, 603105, Nizhny Novgorod, Gagarin ave., 23. Russia (e-mail: davydov@rf.unn.ru).

A. Maltsev is with the Department of Bionics and Statistical Radiophysics, Radiophysics Faculty, N.I.Lobachevsky State University, Nizhny Novgorod, 603105, Nizhny Novgorod, Gagarin ave., 23. Russia (e-mail: maltsev@rf.unn.ru).

$$\begin{aligned} H_0 : \mathbf{x}(t) &= \boldsymbol{\xi}(t), \\ H_1 : \mathbf{x}(t) &= \boldsymbol{\xi}(t) + \mathbf{s}(t, \phi_0, t_A), \end{aligned} \quad (1)$$

where  $H_0$  is the null hypothesis about only noise presence, and  $H_1$  is the alternative hypothesis about additive mixture of complex Gaussian noise  $\boldsymbol{\xi}(t)$  with zero mean and variance  $\sigma_n^2$  and useful signal  $s(t, \phi_0, t_A)$  with unknown parameters AoA  $\phi_0$ , ToA  $t_A$  and power  $\sigma_s^2$  presence [3] - [16]. The form of the signal is the same at all sensors except for the delay due to the difference in propagation times.  $N$  samples of the noise vector  $\boldsymbol{\xi}(t)$  are uncorrelated and hence independent in time and space and identically distributed. The useful signal can be written as

$$\mathbf{s}(t) = s(t)\mathbf{S} \quad (2)$$

where  $s(t)$  - is the complex amplitude of the signal, known or unknown, and a complex phazor vector  $\mathbf{S}$  - is the vector of the wave front, depending on the position of the signal source and the configuration geometry of the antenna array.

Block scheme in the first scenario for the known complex amplitude function  $s(t)$  is presented in Fig 1. In this case, the processing is based on multielement matched filtering (MF). The signal from each element of the antenna array passes to a matched filter. In this figure, the  $X_i(t)$  denoted the corresponding complex amplitude of the signal on each element.

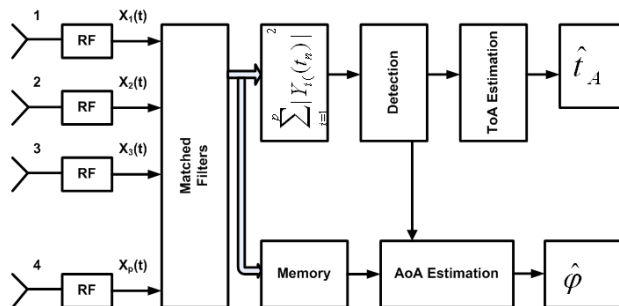

Fig. 1 Block scheme in the first scenario

The signals for signal processing by elements of the antenna array, after conversion into I/Q (quadrature) components go to

the matched filters. The matched filter signal output has the form of the p-element complex vector

$$\mathbf{Y}(t) = \int_{-\infty}^{\infty} h_{MF}(\tau) \mathbf{X}(t - \tau) d\tau, \quad (3)$$

where  $h_{MF}(\tau)$  - matched filter impulse response

$$h_{MF}(\tau) = s(t_0 - \tau). \quad (4)$$

The output signals of MF block register in memory and in parallel go to the combiner block where decision statistics of  $T(t)$  is created as incoherent sum of matched filters outputs:

$$T(t) = \sum_{i=1}^p |Y_i(t)|^2 \quad (5)$$

and is a scaled  $\chi_{2p}^2$  random variable under  $H_0$  and  $H_1$  [6]. After comparing with the threshold received by Neumann-Pearson criterion for the given value of a false alarm probability

$$P_{fa} = \chi_{2p}^2 \left( \frac{\text{threshold}}{\sigma_n^2 E / \sigma_s^2} \right) \quad (6)$$

in case of decision on signal presence, the **ToA estimation** is founded as a maximum of decision statistic  $T(t)$  (see, as example, Fig. 2), and the block of an of **AoA estimation** is activated. For estimating the AoA the output matched filters signal is compared with plane waves coming from all directions. The angle corresponding to the maximum projection of the accepted signal, is defined as the best estimate of AoA.

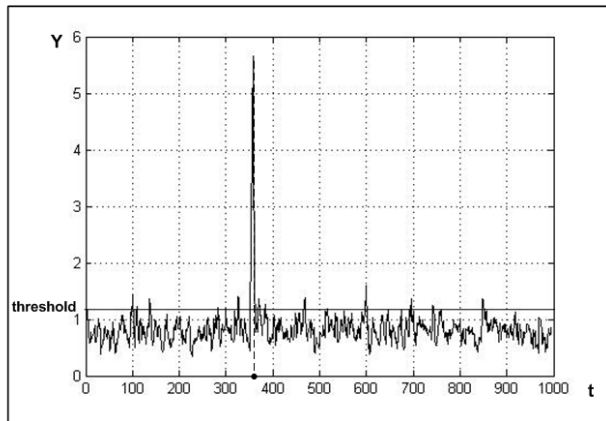

Fig. 2 Principle of AoA estimation

For comparison consider the second scenario corresponds to reception of the signal with the unknown waveform  $s(t)$ . In this case the useful signal can be written as (2) with the random complex amplitude (Gaussian complex signal with a zero mean, variance  $\sigma_s^2$ ). Optimal block scheme for signal processing of the second scenario (MaxLambda) is presented in Fig. 3 [17] - [19].

During processing the signals from the each separate sensor are combined in a vector  $\mathbf{X}$ . Further in a mode of a sliding

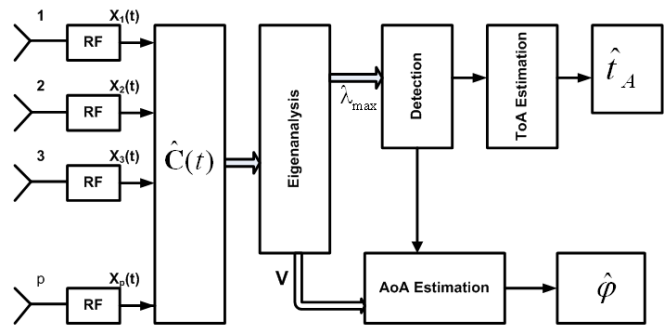

Fig. 3 Block scheme of the second scenario

window estimation of the covariance matrix  $\mathbf{C}$  of the received data is formed in the block  $\hat{\mathbf{C}}(t)$

$$\mathbf{C} = \frac{1}{N} \sum_{\alpha=1}^N \mathbf{X}_{\alpha} \mathbf{X}_{\alpha}^H. \quad (7)$$

Then in block **Eigenanalysis** the spectral decomposition of a matrix made and the maximum eigenvalue  $\hat{\lambda}_{max}$  and corresponding eigenvector  $\mathbf{V}$  selected. Since the maximum eigenvalue of sample covariance matrix is sufficient statistics in this case, the decision is made by comparing of this eigenvalues threshold. CDF of the maximal noise eigenvalue corresponding to a null hypothesis of  $H_{04}$  was received in work [20] and looks like:

$$F_{\hat{\lambda}_1}(\hat{\lambda}_1) = \left| \frac{\gamma(N-p+i-j-1, \hat{\lambda}_1 N)}{\Gamma(N-p+i)\Gamma(j)} \right|. \quad (8)$$

Fig. 2 also suitable for this case, but the statistics  $\hat{\lambda}_{max}$  with the corresponding threshold is compared. Eigenvector  $\mathbf{V}$  will be a vector-phazor ML estimation then it is easy to receive the ML estimation of AoA.

Details on this scenario were considered in the previous works [17] - [20].

## II. SIMULATION RESULTS

To ensure the noise immunity and accuracy of AoA and ToA estimation these scenarios were simulated using MATLAB for 1,2 and 4-element antenna array.

Useful signal was simulated as a Barker code of different length. Probability of the false alarm in this case and in all subsequent experiments was equal to  $P_{FA} = 0.05$ .

In Fig. 4 detection curves (probability of the right detection as functions of the signal-to-noise ratio SNR in one antenna element) for both scenarios are presented. Barker code here has a length of 13 conditional units.

The effect of the useful signal length on the probability of detection is investigated in Fig. 5 and Fig.6. Detection curves in these figures are obtained for a single element of

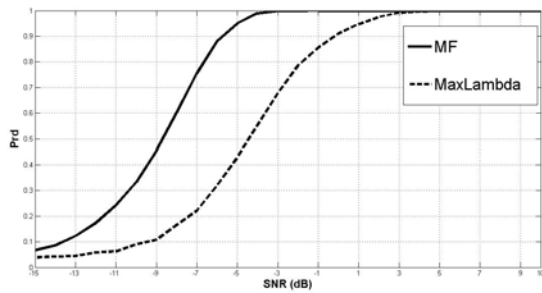

Fig. 4 Detection curves for MF and maxLambda scenarios

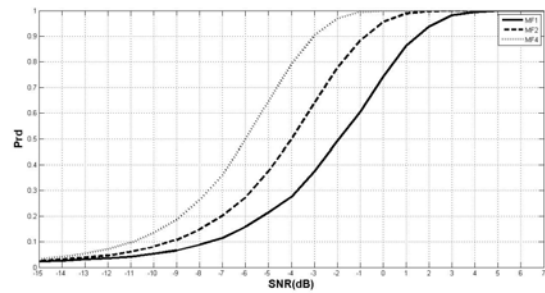

Fig. 7 Detection curves for MF for different number of elements of the antenna array

the antenna array for MF scenario (Fig.5) and MaxLambda scenario (Fig.6). As a useful signal was considered Barker code of length 1, 7 and 13 conditional units. With increasing signal length from 1 to 7 conditional units gain up to 8.5 dB for MF and 5 dB for maxLambda, while increasing signal length from 1 to 13 conditional units gain up to 13 dB for MF and 6.5 dB for maxLambda. Thus, the ratio of gains for these two scenarios can reach two times in favor of matched filtering.

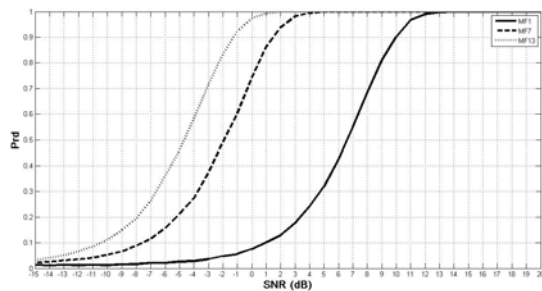

Fig. 5 Detection curves for MF for different useful signals length

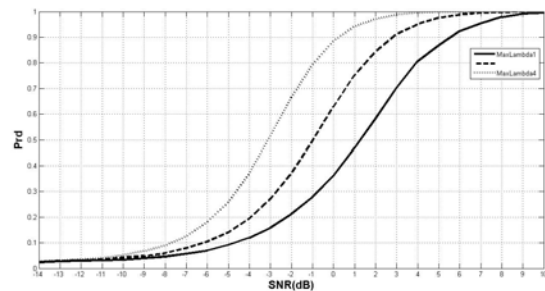

Fig. 8 Detection curves for maxLambda for different number of elements of the antenna array

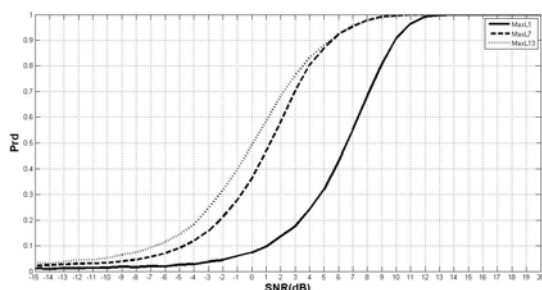

Fig. 6 Detection curves for MaxLambda for different useful signals length

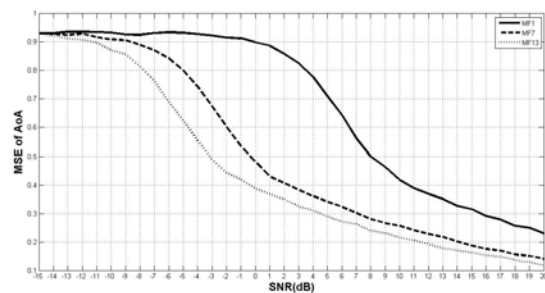

Fig. 9 MSE of AoA for MF for different signals length

The dependence of the probability of the right detection for both scenarios from the number of antenna array elements presents on Fig. 7 for the MF method and on Fig. 8 for maxLambda method. Useful signals length was 7 conditional units. With increasing number of elements of the antenna array MF method gain with respect to the maxLambda method decreases very slowly. Thus, for  $p=1$  it is about 3.3 dB, for  $p=2$  it is 3 dB, for  $p=4$  it is 2.8 dB.

Similar figures are shown in Fig.12 - Fig.14 for MSE of ToA. All of these characteristics are better for the first scenario. However, for the implementation of this scenario requires a complete a priori information about the signal. In conclusion, we may add that the detection curves and estimation of ToA and AoA coincide for the case when the length of the signal is equal to 1 conditional unit, as was expected.

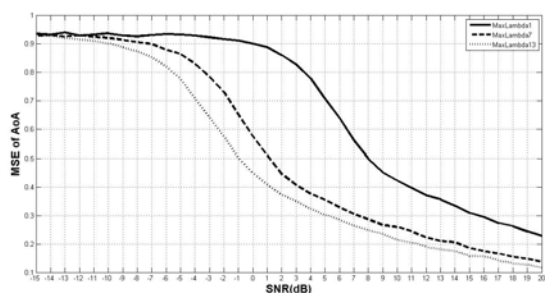

Fig. 10 MSE of AoA for maxLambda for different signals length

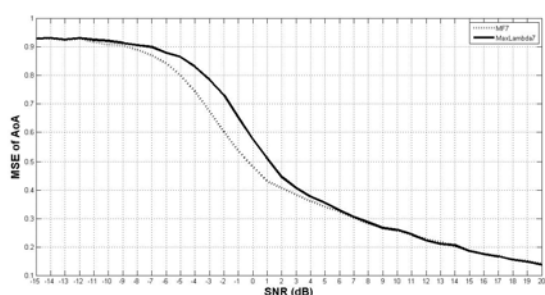

Fig. 11 MSE of AoA for both scenarios

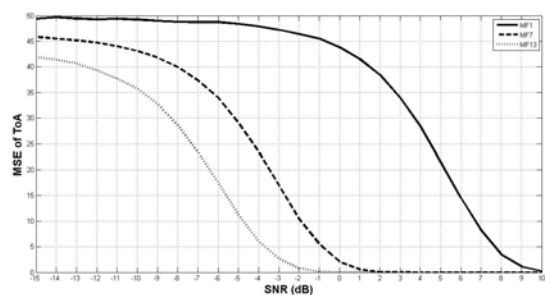

Fig. 12 MSE of ToA for MF for different signals length

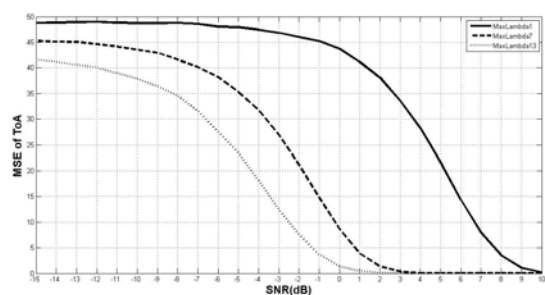

Fig. 13 MSE of ToA for maxLambda for different signals length

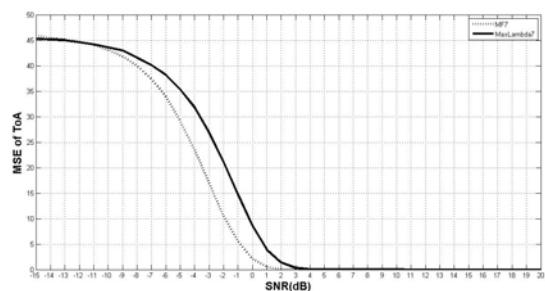

Fig. 14 MSE of ToA for both scenarios

### III. CONCLUSION

Two scenarios, allowing to detect the signal and estimate ToA and AoA, were investigated in this work. Two scenarios were considered: first one, when the waveform of the useful signal is known a priori and, second one, when the waveform of the desired signal is unknown. In the first case sufficient statistics is the value of the response of the matched filter, the second is the maximum eigenvalue of sample covariance matrix. Noise immunity and estimation accuracy for AoA and ToA of MF and MaxLambda scenarios were studied. Results of researches in case of some additional conditions can be applied to a digital communications systems.

### ACKNOWLEDGMENT

The authors would like to thank Konstantin V. Rodushkin from Intel Corporation for valuable discussions of results.

### REFERENCES

- [1] H.L. Van Trees "Detection, Estimation, and Modulation Theory" J.Wiley, New York, 1971.
- [2] O.V. Bolkhovskaya, A.A. Maltsev "The performance of the GLRT for the spatial signals detection with a small number of observations", IEEE Signal Processing Letters, Oct. 2004.
- [3] N.R. Goodman, "Statistical analysis based on a certain multivariate Gaussian distribution", *Ann.Math.Stat.*, March, 1963, Vol.34.
- [4] A. L. Swindlehurst and P. Stoica "Maximum Likelihood Methods in Radar Array Signal Processing". Proceedings of IEEE, vol.86,NO.2, February 1998.
- [5] H. Kamiyanagida, H. Saruwatari, K. Takeda, and F. Itakura, Direction of arrival estimation based on non-linear microphone array, IEEE Conf. On Acoustics, Speech and Signal Processing, Vol. 5, pp. 3033-3036, 2001.
- [6] S. M. Kay, Fundamentals of Statistical Signal Processing: Detection Theory, Prentice-Hall, 1998.
- [7] L.L. Scarf "Statistical Signal Processing", Addison-Wesley, Reading, Mass., 1991.
- [8] V.S. Pugatchev, "The theory of probabilities and mathematical statistics", Nauka, Moskwa, 1979, (in Russian).
- [9] V.F. Klyuev, V.P. Samarin, A.V. Klyuev, Estimation of efficiency of algorithm of measurement of power of noise on the background of narrowband interference. Information-measuring and Control Systems, vol. 10, no 6, pp.72-75, 2012.
- [10] Kwang June Sohn, Hongbin Li, Braham Himed: Parametric GLRT for Multichannel Adaptive Signal Detection. IEEE Transactions on Signal Processing 55(11), 2007.
- [11] P.Chertanomwong,J.Takada,H.Tsuji, Accurate Angle-of-Arrival Estimation Method in Real System by Applying Calibration and Spatial Smoothing, IEICE Trans.Common.,Vol.E90-B No.10 Oct. 2007
- [12] R. Klemm Principles of Space-Time Adaptive Processing. IEE Publishing, 2002.
- [13] R. Klemm Applications of Space-Time Adaptive Processing, IEE Publishing, 2004.

- [14] L. Brennan and I. Reed, Theory of adaptive radar, IEEE Transactions on Aerospace and Electronic Systems, vol. AES-9, no. 2, March 1973
- [15] A.Davydov, G.Morozov, A.Papathanassiou, Advanced interference suppression receiver for LTE-Advanced systems, IEEE PIMRC, 2013. -P. 1337-1341
- [16] A.Davydov, G.Morozov, A.Papathanassiou, Prediction model for turbo-coded OFDMA-systems employing rate matching and HARQ, IEEE VTC-Spring, 2011. -P. 1-4
- [17] O.V. Bolkhovskaya, A.A. Maltsev, K.V. Rodushkin "Comparative analysis of different statistics for spatial signal detecting in the short samples case". Radiophysics and quantum electronics, Vol 47, N 8, 2004.
- [18] Bolkhovskaya, O. V.; Mal'tsev, A. A. "Determination of Threshold Values of the Generalized Likelihood Ratio in the Problem of Detecting Partially Coherent Spatial Signals in the Case of Short Samples". Radiophysics and Quantum Electronics, Volume 45, Number 12 (2002) .
- [19] O.V. Bolkhovskaya, A.A. Maltsev, "Efficiency of different GLR test-statistics for spatial signal detecting". ICECECE 2012: International Conference on Electrical, Computer, Electronics and Communication Engineering, 6-7 December 2012, Australia, Perth. Issue 72, pp. 260-265.
- [20] Rodushkin K.V., Ph.D. Thesis, 2001