

# Simulation Method for Determining the Thermally Induced Displacement of Machine Tools – Experimental Validation and Utilization in the Design Process

G. Kehl, P. Wagner

**Abstract**—A novel simulation method to determine the displacements of machine tools due to thermal factors is presented. The specific characteristic of this method is the employment of original CAD data from the design process chain, which is interpreted by an algorithm in terms of geometry-based allocation of convection and radiation parameters. Furthermore analogous models relating to the thermal behaviour of machine elements are automatically implemented, which were gained by extensive experimental testing with thermography imaging. With this a transient simulation of the thermal field and in series of the displacement of the machine tool is possible simultaneously during the design phase. This method was implemented and is already used industrially in the design of machining centres in order to improve the quality of herewith manufactured workpieces.

**Keywords**—Accuracy, design process, finite element analysis, machine tools, thermal simulation.

## I. INTRODUCTION

QUALITY problems of workpieces, which have been produced by metal cutting like turning, milling or boring are due to approx. 70% by thermally induced displacements of the production system (consisting of machining centre, cutting tool and fixture) [1]. To achieve future improvements from the designers point of view machining centres have to be designed in the way that thermally induced relative displacements between tool and workpiece are minimized during run-up and operation.

The overall thermal balance of a machining centre is basically affected by two types of disturbance:

The heat loss of drive trains and components (drives, ball screws, bearings, gears, couplings, pumps etc.) as well as thermal losses of the cutting process itself heating up the tool, the workpiece, the dispersing chips and possibly the cooling lubricant are the so called *internal disturbance variables*.

In addition to that the *external disturbance variables* (variable ambient temperature, air flow, incident solar radiation, radiation of room heating devices, bad isolated baseplates etc.) are of utmost importance [2].

The heat losses of drive trains gained more and more importance during the last decades because of enhanced heat generation resulting from higher feed axis dynamics,

G. Kehl is with the University of Applied Sciences, Faculty of Management, Flandernstr. 101, 73732 Esslingen, Germany (e-mail: gerhard.kehl@hs-esslingen.de).

P. Wagner is with Gebr. HELLER Maschinenfabrik GmbH, Gebrüder-Heller-Str. 15, 72622 Nürtingen, Germany.

increasing main spindle performance and higher level of automation in general.

Despite installation and operation of machining centres in any climate region the customer-demanded precision of machining centres raised continuously. High-precision operations were claimed not only from corresponding special machines but with increasing tendency also from conventional machining centres. Additional installations for climate control of manufacturing plants, which could reduce the thermal loads on machining centres, are customarily defeated because of further costs.

In spite of decades of experience and elaborated design the machining centre manufacturer HELLER is still anxious to reduce the displacement due to thermal factors (the so-called thermal growth) to cope with the customers growing requirements regarding the accessible precision of cutting processes.

Basically the thermal growth of machining centres can be improved by CNC-compensation algorithms, but as a result of different intern and extern disturbance variables the thermal growth is not easy to predict and by all means requires additional sensors and controllers. Furthermore pricy customer-specific control functions are necessary, which can only be qualified on the real machining centre. For this case the compensation of stationary thermal growth can take place by now on the basis of temperature measurements and non-transient finite element analysis (FEA) [3], but here the underlying FEA models are only media for deducting compensation strategies and not able to support the design process of machining centres in a professional and highly qualified way.

In summary all known and realized mechatronical procedures to reduce the thermal growth until now are inaccurate, because they usually do not control the thermal growth of the overall system by a closed-loop but only affect some subsystems.

## II. TARGET FIGURE

Independently from manifold possibilities occurring by CNC-compensation algorithms it would be desirable to apply simulative methods regarding the thermal growth during the design phase of machining centres. Those methods should deliver authoritative forecasts of the temperature-time-behaviour as well as the displacement-time-behaviour and thereby open the way to a systematic evaluation and

optimization of alternative conceptual variants concerning their thermal system behaviour.

### III. EXPERIMENTAL ANALYSIS

After ten years of experience with FEA in the field of static and dynamic analysis, suitable models were adapted in a way that transient simulations of temperature fields and resulting thermal growth are possible in order to approach the mentioned target figure. For evaluation of this models experimental testing on machining centres and the most important machine elements were carried out coincidentally.

Over a period of several years improvements on FEA models, the simulation process and the experimental setups were achieved. In doing so marginal modifications on measured machining centres were carried out with the objective of increasing the overall reliability of the measurements procedure.

To have a bottom-up strategy in this challenging subject different load cases were analysed by experiment and simulation:

- 1) constant ambient temperature, drive control off, defined local warming by heating pad
- 2) constant ambient temperature, main spindle cycles
- 3) constant ambient temperature, X-, Y-, Z- or B-axis feed and combinations
- 4) ambient temperature cycles (ramps with followed steady conditions), drive control off or on
- 5) ambient temperature cycles (day-night-cycles), drive control off or on
- 6) ambient temperature cycles (day-night-cycles), main spindle cycles
- 7) ambient temperature cycles (day-night-cycles), X-, Y-, Z-, B- or C-axis feed and combinations.

Due to the complexity of this issue and for securing a step-wise systematic approach serially implemented temperature compensation control algorithms were switched off during the experimental analysis of the machining centres. This concerns just as well the cutting process and the coolant lubricant usage, which were neglected in the considerations firstly. Previous to, during and after the analysis this procedure appeared as necessary, reasonable and constructive.

However it is clear, that widening the simulation concerning more realistic conditions of machining centre operations has to be carried out, as soon as the above mentioned load cases are treated sufficiently and understood completely just as fair correlation of experiment and simulation is reached.

Load cases 1 to 4 were arranged in a climatic chamber at the Fraunhofer-Institute for Machine Tools and Forming Technology (IWU) in Chemnitz (Fig. 1); load cases 5 to 7 in a non-air-conditioned factory work floor at Gebr. HELLER Maschinenfabrik GmbH in Nürtingen (Fig. 2) withbringing the following essential measurement categories into focus:

- a) absolute displacement at tool centre point and workpiece (Invar®steel setup, Fig. 3)
- b) relative displacement and decline between tool and workpiece (Fig. 4)

- c) relative displacement between tool centre point and machine bed
- d) relative displacement between column and machine bed
- e) temperature at 34 points of measurement at the machining centre
- f) air temperature layering besides the machining centre (staged in 500mm height grid)
- g) air temperature layering inside work space (staged in 300mm height grid)
- h) thermal field by means of thermography in selected regions of the machining centre.

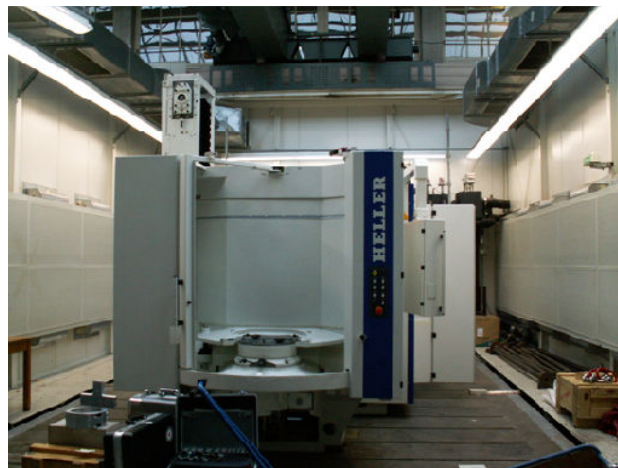

Fig. 1 Machining centre in climatic chamber



Fig. 2 Machining centre and thermography camera in factory work floor

### IV. FEA MODELING AND SIMULATION

Prior to doing a transient simulation of thermo-induced displacements a transient simulation of the thermal fields is necessary. Those thermal simulations of the machining centre are carried out in defined time steps within the thermal model, which involves 10-node tetrahedral thermal solid elements, thermal shells and 3-D conduction bars.

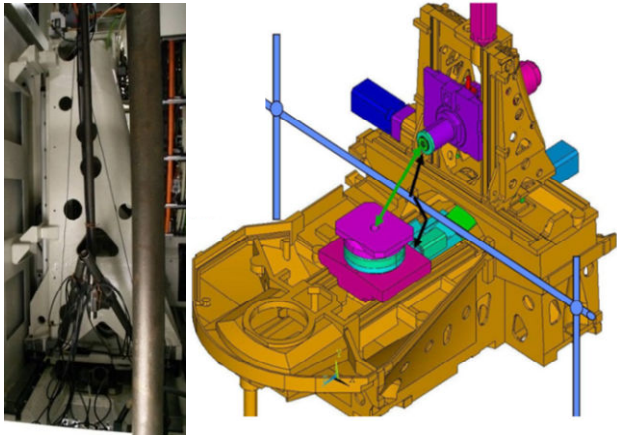

Fig. 3 Invar® steel setup in machining centre

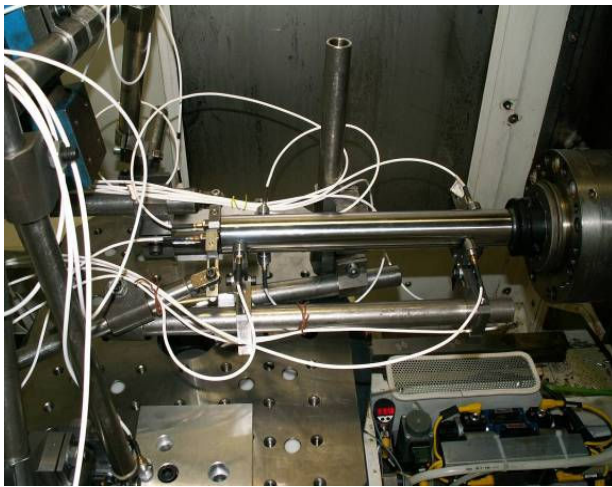

Fig. 4 Displacement and decline measurement setup

Reasonable time step discretization (e.g. 3 minutes) can be found by analysing the time constants taken from PT1-behaviour relating to the response between ambient temperature progress and relative displacement between tool centre point and workpiece (as shown for  $T_Y$  and  $T_Z$  in Fig. 5).

Subsequently the thermal fields are imported as thermal loads into the mechanical model. This model includes 10-node tetrahedral structural solid elements, stiffness matrices, spring-damper elements, mass points and enables to calculate the resulting thermo-induced displacements.

The FEA model of the machining centre is descended almost directly from the 3D-CAD-design process chain and exhibits high geometry complexity (e.g. > 5000 areas). This is necessary from the view of rapid design processes, because geometrical defeaturing of major kind results in additional operating expenses and puts the wanted closeness of design and simulation at a risk, because of generating redundant data and losing the principle of simultaneous engineering.

Hence the presented innovative modeling approach employs the geometry data of the overall model for a detailed identification of the heat transfer behaviour by on the one hand representing the heat conduction and on the other hand fully-automated allocation of different convection and

radiation parameters for every exterior finite element surface (e.g. > 90.000 exterior element surfaces), as can be seen from several area examples in Fig. 6).

For the implementation of this approach several algorithms were necessary, which will be explained roughly in the following subchapters, differing in the fully-automated allocation of convection parameters and ultimately radiation parameters.

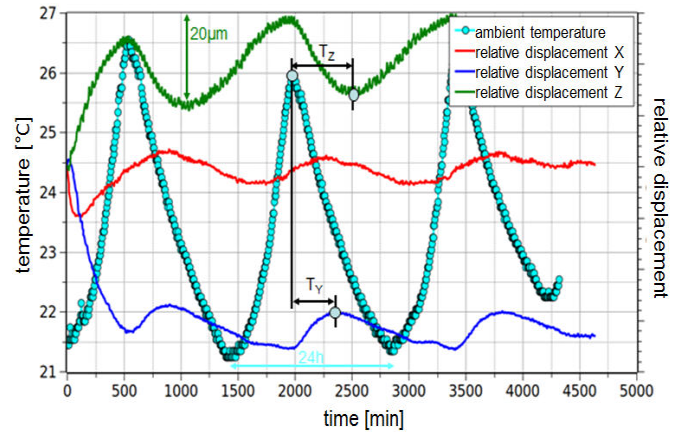

Fig. 5 Ambient temperature (day-night-cycles) and relative displacements (load case 5)

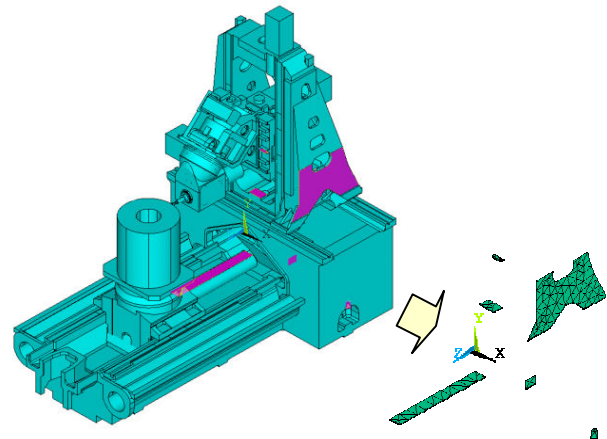

Fig. 6 Exemplary areas for fully-automated allocation of convection and radiation

#### A. Geometry-Based Allocation of Convection Parameters

For every exterior element surface a normal vector is generated in order to calculate different heat transfer coefficients dependent from spacial surface orientation. Fig. 7 visualizes the vector arrows for a model detail.

The presented approach is based on the grouping of surfaces (vertical, horizontal, inclined) in VDI-Wärmeatlas [4]. At this juncture the heat transfer coefficients are created by the Nusselt and Grashof numbers, which are also influenced by the overflow length of the area of which an exterior element surface is a member of.

Every exterior element surface has to be classified anymore in free or forced convection according to the state of motion,

e.g. suitable to the location of linear and rotatory motion drives in the machining centre. Because the state of motion is not constant at any time during feed motion (stop, acceleration, constant velocity, ...) the motion profile has to be interpreted and a medium speed is presumed. This seems to be permissible, because the thermal time constants of all machine components are clearly larger than the time portions of any axis motion.

Fig. 8 visualizes the heat transfer coefficients of exterior element surfaces determined in the mentioned way by coloured element edges.

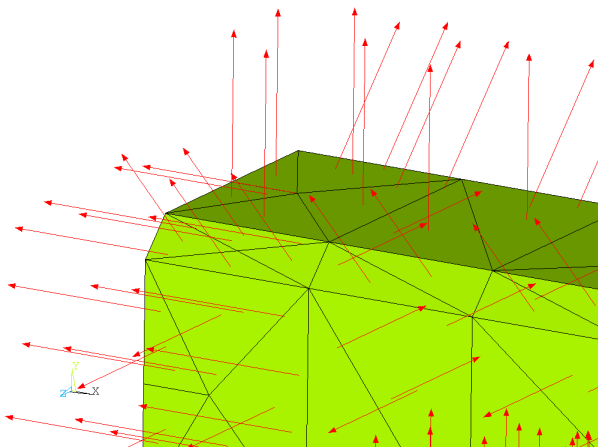

Fig. 7 Normal vectors of element surfaces

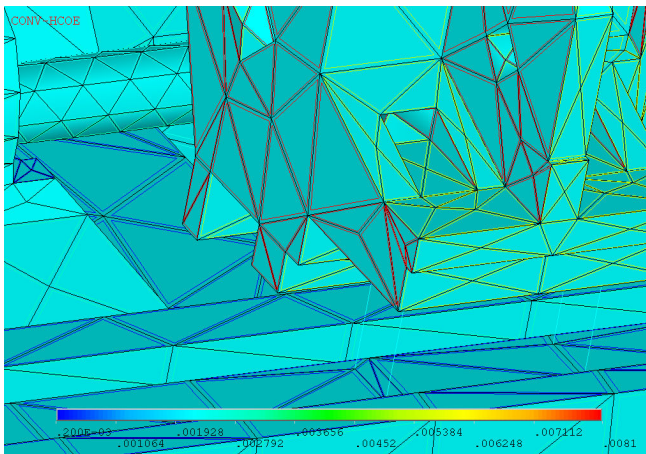

Fig. 8 Heat transfer coefficients of element surfaces

By analysing the height coordinate of every exterior element surface a consideration of air temperature layering, which appears to be relevant proved by measurement (Fig. 9), is possible and can be treated well in a transient simulation as can be seen from Fig. 10.

Whereas the overflow lengths of areas depend from geometry only and do not change during a transient analysis the heat transfer coefficients still unfortunately are time-variant because they depend on the actual thermal field. As a consequence an update of the convection parameters is necessary regularly for every time step of a transient analysis.

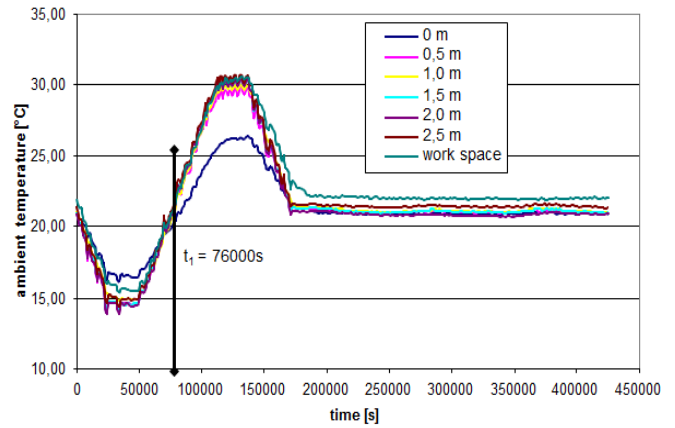

Fig. 9 Ambient temperature ramp cycle (with influence of height above floor)

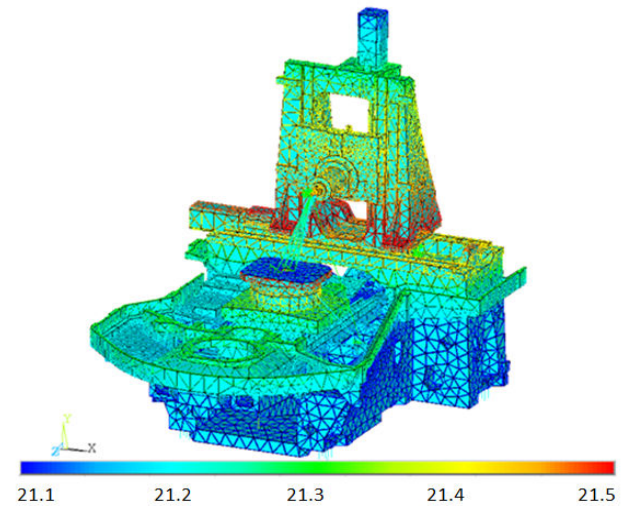

Fig. 10 Ambient temperature in °C on exterior element surfaces at time  $t_1$

### B. Geometry-Based Allocation Of Radiation Parameters

In numerous publications the presumption is expressed, that radiation for representing the thermal behaviour of machine tools [5] (and even workpieces [6]) can be neglected. This presumption was disproved by the authors during extensive experimental and simulative research on multitudinous machining centres of different size and layout. Just as the attempt to separate the heat transfer by convection and radiation in measurement setups [7], both heat transfer mechanisms should in principle be considered separately in a thermal simulation of machining centres. Indeed the consideration of radiation can be simplified by heat transfer coefficients, which include convection and radiation [8], but the quality of such results is strongly limited. For this purpose Fig. 11 shows different convection scenarios appearing during machine operation, whereas radiation in inner hollows may be unaffected. This helps to imagine why radiation modeling apart from convection modeling generates much better results, especially for common hollow grey cast iron structures like machine beds and columns, where natural convection behaviour does not correlate dependable with radiation

behaviour. To clarify this issue the hollows in mechanical structures (e.g. Fig. 12) can be found by applying an algorithm based on the form factor matrix.

By treating the problem adequately the interaction by radiation for every exterior element surface to all others is taken into account by this matrix. Herein the visibility of exterior element surfaces among each other as a result of the overall machine geometry is documented.

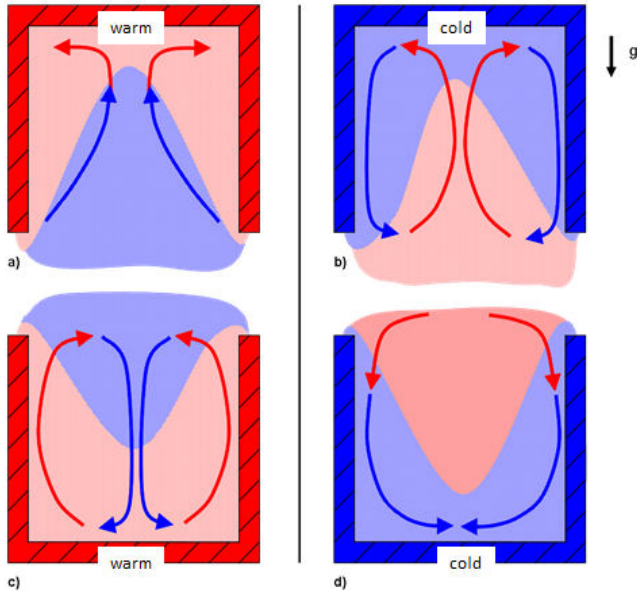

Fig. 11 Convection scenarios for hollow structure

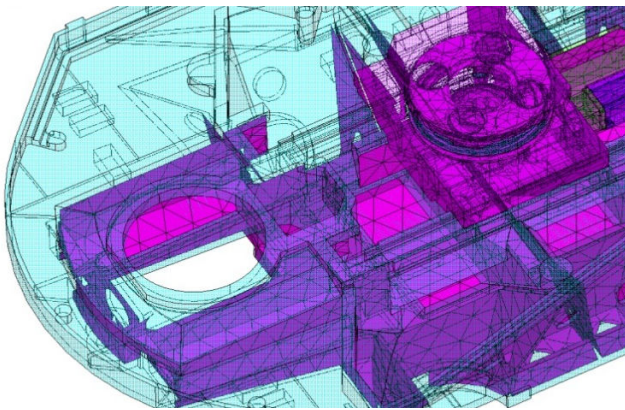

Fig. 12 Inner hollows in grey cast machine bed

Fig. 13 indicates the form factor sums of exterior element surfaces of a machining centre with omitted protective enclosure, showing small values in outer regions meaning that the radiation to the surroundings is dominant. In inner regions the radiation happens in the first instance between the surfaces of the machining centre whereas the radiation to the surroundings is low.

In order to bear in mind the sophisticated visibility at blockades (e.g. protective enclosures, covers, control cabinet) by the form factor matrix, such components should be part of the model and can be considered in so-called radiation enclosures. Fig. 14 depicts a FEA model of a machining centre

containing fundamental parts of visual blockades. The red, green and orange coloured arrows represent the heat transfer by radiation in three regions with high radiation intensity (namely near the feed drives).

As we have seen so far the machining centre radiates to the surroundings and reverse, depending on the actual temperature difference. Generally the relevant surroundings in terms of radiation are not parts of the FEA model but apparently important, meaning that at least a reasonable room floor and wall temperature has to be considered time-dependently, since it obviously affects the heat transfer by radiation.

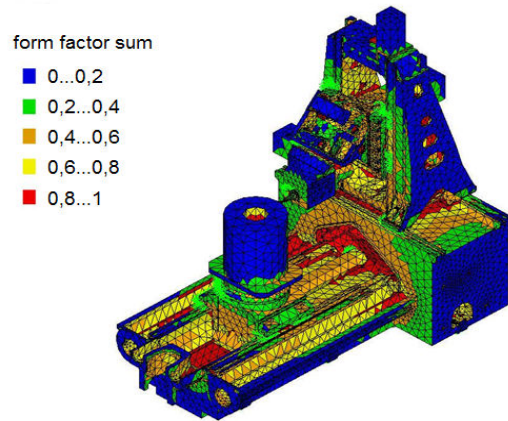

Fig. 13 Form factor sums on element surfaces

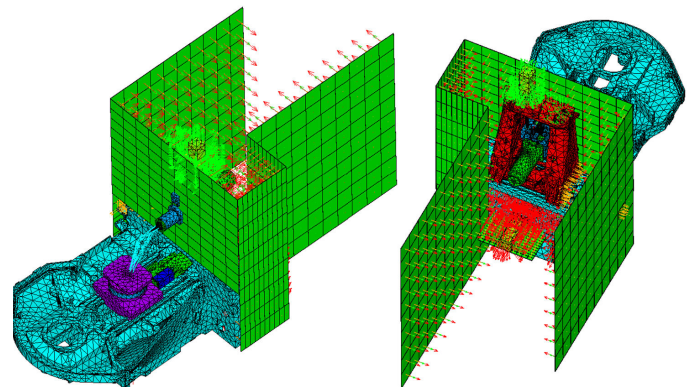

Fig. 14 Heat transfer by radiation with blockades

Fortunately the radiation parameters taken from the form factor matrix are non-time-variant, because the visibility of exterior elements surfaces among each other is a result of the overall machine geometry only, which is mandatorily assumed to be unchanged. As a consequence an update of the form factor matrix and their interpretation can be ceased during a transient analysis.

### C. Modeling the Thermal Behaviour of Machine Elements

The most important elements of machining centres (e.g. linear guides, bearings, ball screws, machine levelers) were focussed on during experimental testing in a climatic chamber with the intention to generate sufficient data for creating simplified analogous models relating to their thermal

behaviour. Simple models are favored because they have to be inserted in the FEA overall machine model afterwards.

The thermal conduction of those machine elements is even relevant in the case of modeling a machining centre with non-moving feed axes. Experimental testing showed that for moving ball screws and linear guides (and other components involving significant friction) it is additionally essential to model their behaviour as heat source. The modeling of linear moving heat sources was implemented in a simplified way by statistical analysis of CNC programs displaying the probability of presence of a moving heat source at a defined axis position. This simplification seems to be valid, because the thermal time constants of all machine components are clearly larger than the time portions of the axis motion.

As representative for large quantities of experimentally analysed machine elements Fig. 15 visualizes the thermal field of a machine leveller by means of thermography in consequence of a heat flow step at the upper surface and conduction behaviour of the leveller. It displays (in red) the measured temperature-time-behaviour at the lower surface, which is used for approximation (all other curves) of a simplified analogous model to be implemented in the FEA model of a machining centre.

For the above mentioned types of machine elements a data basis was established, which can be used by the participants of those studies for further design processes with supporting simulations concerning the thermal growth.

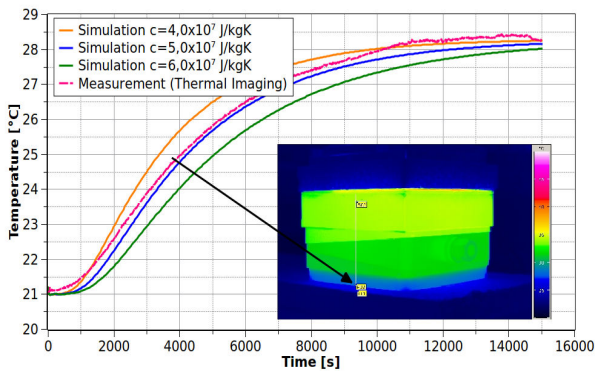

Fig. 15 Thermal field and approximation of temperature-time-behaviour for a machine leveller

#### D. Modeling the Thermal Behaviour of Drives

For modeling the heat flows initiated by feed drives and main spindle drives the torque-creating currents were monitored in the CNC control during machine operation (Fig. 16). Associated with the coil resistance the relevant heat sources could be identified and considered in the FEA model. Numerous thermography images for different load collectives especially in the region of heat sources were used to qualify the behaviour of the heat sources and their surroundings. Fig. 17 shows an example of thermography imaging in the drive train region of a machining centre.

For correctness of the model behaviour relating to mechatronical functioning (incl. actuators, sensors and controllers) node couplings have to be implemented

incorporating the location of the position measuring systems in the machining centre. An entire modeling of the control loops, as shown in [9], is unnecessary for this kind of simulation.

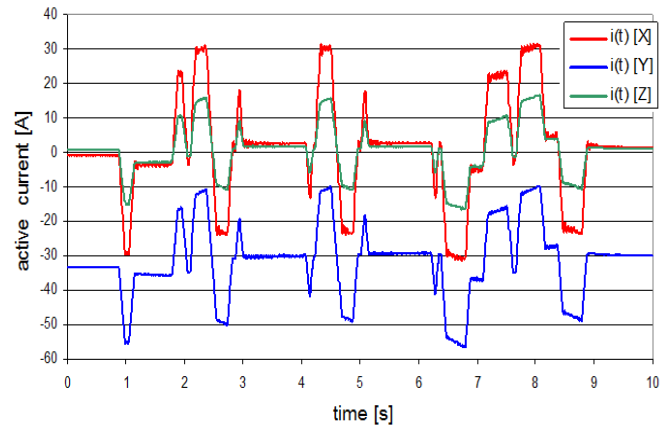

Fig. 16 Active currents of feed drives

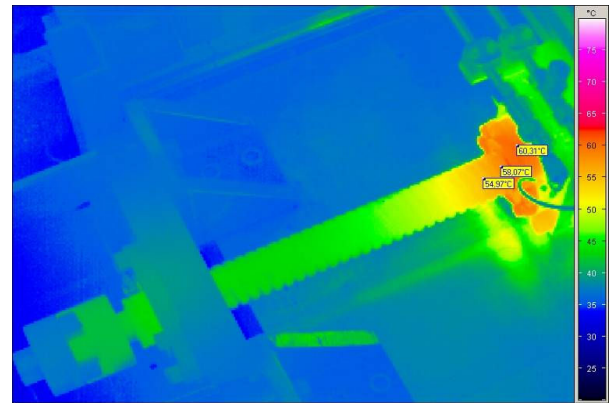

Fig. 17 Thermography image of ball screw drive

#### V. COMPARISON OF SIMULATION AND EXPERIMENT

The mentioned workflow of modeling and simulation is nearly completely automated in ANSYS APDL. Comparing the results of simulation and experiment shows satisfactory accordance in many cases, leading to the fact that this simulation method was already employed in the product design processes of a few machining centres. Fig. 18 demonstrates exemplarily a typical thermal field of a 5-axis-machining centre (here: loadcase 7) and Fig. 19 indicates measured and simulated relative displacements between tool and workpiece (here: loadcase 1).

As can be seen from Fig. 19, accordance is qualitatively good, but there is still a considerable difference between model and reality. For other load cases and conditions yet larger differences may appear.

Possible causes for *inaccurately simulated thermal fields* have been sought for and may be:

- The convection is represented unsatisfactorily on basis of empirical formulas. (This can be improved only by a CFX analysis, which seems to be unrealistic for geometry taken directly from the 3D-CAD-design process chain.)

- b) The thermal model does not contain all covers, which are relevant for air flow and/or radiation.
- c) Peripheral heat sources and heat sinks (e.g. hydraulic pump, hydraulic circuit, cooling circuit of main spindle, internal and external coolant lubricant flow, auxiliary drives) are considered imperfectly.
- d) The heat transfer behaviour of joints (e.g. bolted fastening, welded connections) is modeled in an idealized manner.

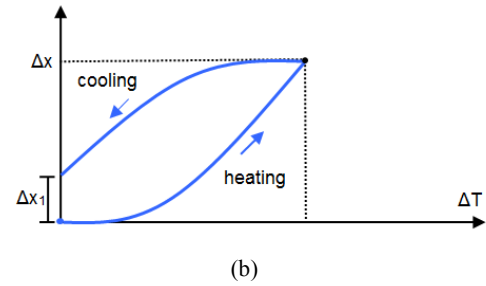
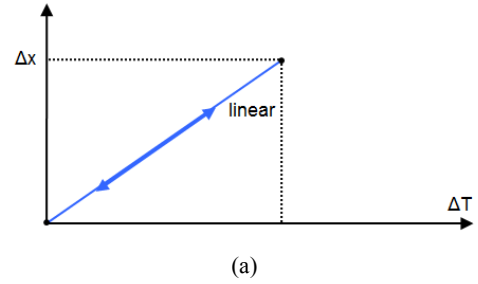

Fig. 20 Linear joint (a) and joint with friction (b)

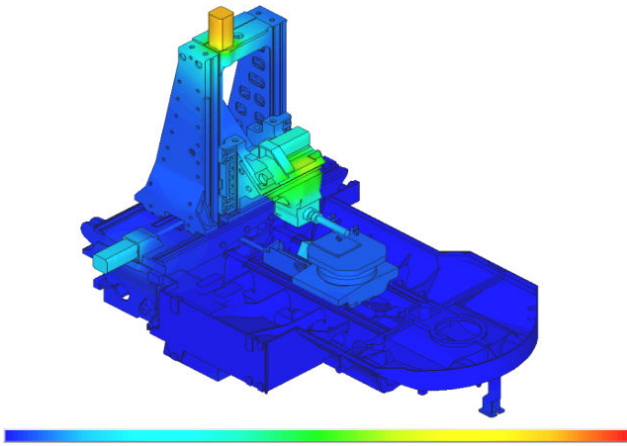

Fig. 18 Temperature field in °C (loadcase 7)

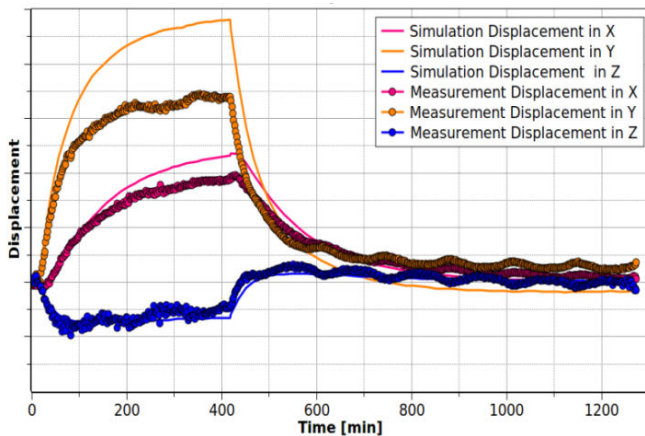

Fig. 19 Measured and simulated displacements

Possible causes for inaccurately simulated displacements may be:

- a) The material parameters (e.g. heat capacity, thermal expansion) imply uncertainties.
- b) The thermally induced displacement of joints in the machining centre is modeled linear (Fig. 20 (a)) and does not include friction and hysteresis (Fig. 20 (b)).

## VI. CONCLUSIONS AND OUTLOOK

The identified shortcomings in the proposed simulation method for the thermal growth of machining centres are motivation for further improvements. On basis of this method as it is now a systematic evaluation and optimization of alternative conceptual variants concerning their thermal system behaviour is already possible.

Hands-on experiences of this method in the industrial design process chain for machining centres are manifold. As a further application Fig. 21 shows the result of a time step in question whether a grey cast iron or polymer concrete machine bed was the suitable choice for specific conditions of a 5-axis-machine, which is designed for mold and die production.

In Fig. 22 the influence of drive concepts (ball screw or rack-and-pinion drive) on the thermal growth of a large 4-axis-machining centre, which is used for chip removal on transmission cases for wind turbines, was studied.

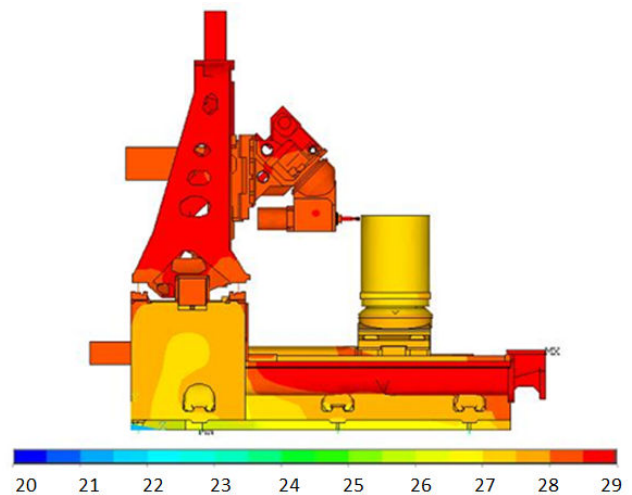

Fig. 21 Thermal field of 5-axis-machining centre

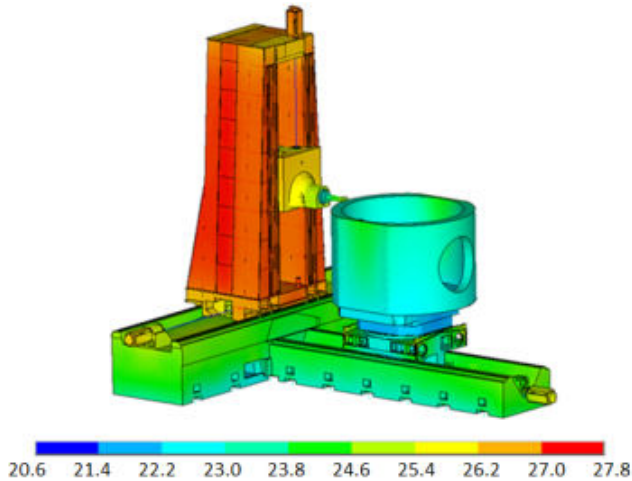

Fig. 22 Thermal field of 4-axis-machining centre

#### ACKNOWLEDGMENT

The presented simulation method was generated in context of the project “Simulation of the Thermal Growth of Machine Tools” by the workshop “Design of Machine Tools” of the Verein Deutscher Werkzeugmaschinenfabriken (VDW) [10]. Contributors to this work were IWU Chemnitz and mainly Gebr. HELLER Maschinenfabrik GmbH [11], [12].

#### REFERENCES

- [1] Bryan, J.: International Status of Thermal Error Research. In: Annals of the CIRP Vol. 39/2/1990.
- [2] Weck, M.; McKeown, P.; Bonse, R.; Herbst, U.: Reduction and Compensation of Thermal Errors in Machine Tools. In: Annals of the CIRP Vol. 44/2/1990.
- [3] Denkena, B.; Schar Schmidt, K.-H.: Kompensation thermischer Verlagerungen. In: wt-online 97 (2007) H. 11/12.
- [4] N.N.: VDI-Wärmeatlas, 10. Auflage (2006).
- [5] Ess, M.: Thermische Simulation von Werkzeugmaschinen. In: Tagungsband des IWF-Symposiums: Simulation von Werkzeugmaschinen, Zürich, 13.1.2009.
- [6] Fleischer, J.; Pabst, R.; Zanger, F.: Modellierung des Wärmeeintrages bei der Trockenbearbeitung von Fahrzeugkomponenten aus Grauguss. In: Spanende Fertigung, 5. Ausgabe, Vulkan-Verlag, Essen, 2008.
- [7] Heisel, U.; Popov, G.; Stehle, T.; Dragov, A.: Wärmeübergangsbedingungen an Werkzeugmaschinenwänden. In: *dima die maschine* 57 (2003), Nr. 4, pp. 24 – 27.
- [8] Schmitt, T.: Modell der Wärmeübertragungsvorgänge in der mechanischen Struktur von CNC-gesteuerten Vorschubsystemen. Dissertation an der TH Darmstadt, 1995.
- [9] Kehl, G.; Wurzberger, P.: Integrierte Simulation von Strukturmechanik und Regelungstechnik an Bearbeitungszentren. CADFEM-Informationstag: Gekoppelte Regelkreissimulation in ANSYS, Fellbach, 25.4.2007.
- [10] Würz, T.: Verbesserung der Simulationengenauigkeit beim Wärmegang an Werkzeugmaschinen. FWF-Forschungsinform Nr. 22 / Oktober 2007.
- [11] Neugebauer, R.; Zwingenberger, C.; Schädlich, K.; Vesely, J.: Simulation des Wärmegangs von Werkzeugmaschinen. Final Report of German Research Project FWF Nr. 2609, Term: 01.09.2005 to 30.06.2008.
- [12] Neugebauer, R.; Zwingenberger, C.; Kehl, G.: Improving the Precision of Machine Tools by Thermal Simulation. In: *ATZproduktion*, 03-04 / September 2009.