

Equipment Design for Lunar Lander Landing-Impact Test

Xiaohuan Li, Wangmin Yi, Xinghui Wu

Abstract—In order to verify the performance of lunar lander structure, landing-impact test is urgently needed. And the test equipment is necessary for the test. The functions and the key points of the equipment are presented to satisfy the requirements of the test, and the design scheme is proposed. The composition, the major function and the critical parts' design of the equipment are introduced. By the load test of releasing device and single-beam hoist, and the compatibility test of landing-impact testing system, the rationality and reliability of the equipment is proved.

Keywords—Landing-impact test, lunar lander, releasing device, test equipment.

I. INTRODUCTION

WHEN the lunar lander lands on the lunar surface, the impact loads and potential energies borne by it should be absorbed adequately by the buffer to prevent damage [1]-[3]. The soft landing of the lunar lander is one of the stages that the structure of the lander and instruments on it bear the most sophisticated and harshest dynamic environment [4], [5]. In order to investigate the touchdown impact-resistance characteristics of the lunar lander and then verify its stability and reliability when soft landing, landing-impact tests on earth are urgently needed.

An air-drop system is used to simulate the process of soft landing for the landing-impact test. The lunar lander can be lifted to a predetermined altitude, released for freely falling, and then finally lands on the simulated lunar surface at some velocity and attitude [6]. The process of the test is monitored and the data is collected by the high speed video system and the impact-response testing system respectively. The test equipment is a key component of this whole complicated system for the landing-impact test and one kind of this equipment is designed in this work.

II. REQUIREMENTS FOR THE DESIGN OF THE TEST EQUIPMENT

The lunar lander is made a freely falling body to simulate the velocity and attitude of landing process. Therefore some functions are needed for the test equipment:

- 1) Hoisting function: the lunar lander can be hoist to a specified altitude and the center of mass can be adjusted by the test equipment to obtain an initial attitude needed for different testing purposes.

Xiaohuan Li is with the Beijing Institute of Spacecraft Environment Engineering, China (phone: 8610-687-44710; fax: 8610-687-46751; e-mail: lixhdyx@163.com).

Wangmin Yi and Xinghui Wu are with the Beijing Institute of Spacecraft Environment Engineering, (e-mail: yiwangmin79@hotmail.com, wuxinghuimail@163.com).

- 2) Releasing function: after the lunar lander is adjusted to a satisfied attitude, the test equipment should be unlocked quickly to release the lander at an initial velocity for freely falling to the landing surface. Collision, interference and other similar relative movements between the equipment and the lander are not acceptable during this process. The unlocking motion should be simple, reliable, controllable and repeatable.
- 3) Attitude adjusting function: limited by its structure design, the lunar lander only has two hoist points, which makes the waggle unavoidable. Therefore the test equipment must have the function to adjust and make the releasing attitude of the lander stable.
- 4) Spacing function: the data collection work is conducted at the moment of soft landing on the simulated surface and collision between the test equipment and the landing surface is unacceptable to avoid the influence on the collecting data, which leads to the necessity of the spacing function for the test equipment to control its trajectory.

To make all the functions mentioned available for the fulfillment of the landing-impact test mission, several technical difficulties depicted as follows have to be solved:

- 1) The rapid response of the test equipment to the releasing order. The test equipment should have a quick response unlocking apparatus to meet the strict requirements for the initial releasing attitude and velocity. Otherwise, the accuracy of the test could not be guaranteed.
- 2) The control of the releasing attitude. Since the hoisting status of the lunar lander is unstable, large deviation is to be caused if the initial releasing attitude could not be controlled at the specified altitude.
- 3) The noninterference of the equipment. The free fall movement of the lunar lander and the collection of the landing data should not be influenced by the test equipment to assure the accuracy of the test.

The design of the test equipment with characteristics above mentioned is the premise of the landing-impact test.

III. DESIGN OF THE TEST EQUIPMENT

In this section, the design of the test equipment based on the function requirements of the landing-impact test is proposed. The test equipment consist of releasing device, single-beam hoist, attitude adjusting instrument and spacing cables, as shown in Fig. 1. The single-beam hoist is connected to the lunar lander by two connectors for hoisting altitude control. Spacing cables are installed and connecting the releasing device and single-beam hoist to realize the spacing function. Attitude adjusting instrument is needed for the initial attitude control.

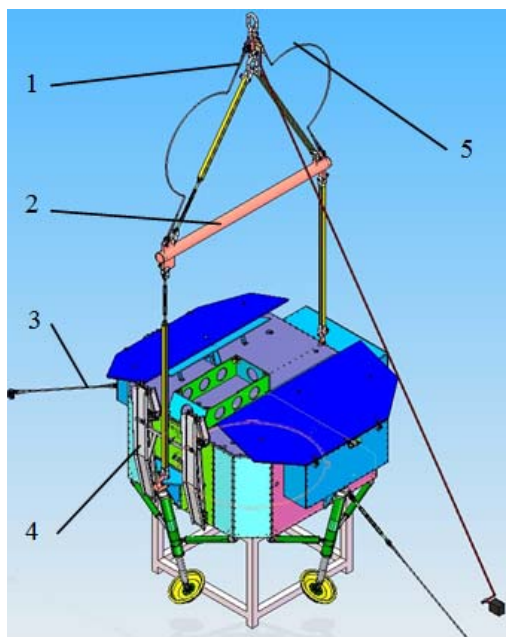

Fig. 1 Test equipment of landing-impact test: 1. releasing device, 2. single-beam hoist, 3. attitude adjusting instrument, 4. lunar lander, 5. Spacing cable

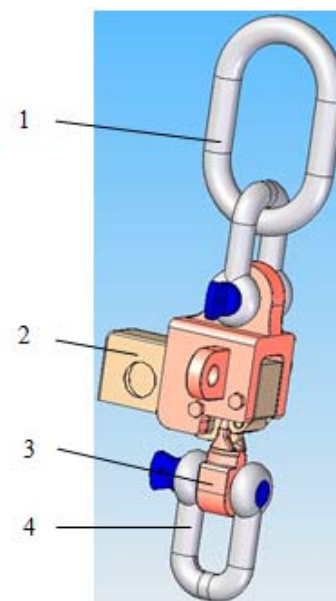

Fig. 2 The structure of the releasing device: 1. hoisting ring, 2. Spring hook, 3. lifting lug, 4. shackle

Connect the components according to Fig. 1 before the test, hoist the lunar lander to specified altitude and then adjust the attitude for release. After unlocking the releasing device, the single-beam hoist falls together with the lander and its falling distance is controlled by the spacing cables to avoid collision or interference when the lander lands on the surface. The mass of the two connectors that connect the hoist points of the lander and the single-beam hoist is so small in comparison with the mass of the lander that its influence on the test result can be ignored.

A. Design of the Releasing Device

The releasing device is one of the key components to guarantee the effectiveness of the landing-impact test since its response characteristics determine the initial status of the lunar lander, which immediately affects the movement trajectory of the lander. The releasing device consists of hoist ring, spring hook, lifting lug, shackle and so on, as shown in Fig. 2. Hang the hoist ring on the hook of crown block, install the single-beam hoist on the shackle and then push the lifting lug into the nip of the spring hook for using preparation. The lunar lander can be released by pressing the control button to unlock the spring hook.

The spring hook is designed for high altitude hanging and releasing purpose and consist of rocker system, groove shell and electromagnetic release unit. The nip of the rocker system is kept closed. After hanging the object into the nip, it can be opened by the rocker system driven by the electromagnetic release unit to release the hanging object.

B. Design of the Single-Beam Hoist

The lunar lander is connected with the single-beam hoist by the connectors for hoisting purpose. Adjustment screws are installed on the vertical hoisting sling and the inclined hoisting sling to adjust the position of the hoisting ring, which makes the hoisting direction in line with the centroid of the lunar lander and assure the lander can be hoisted stably. The structure of the single-beam is shown in Fig. 3.

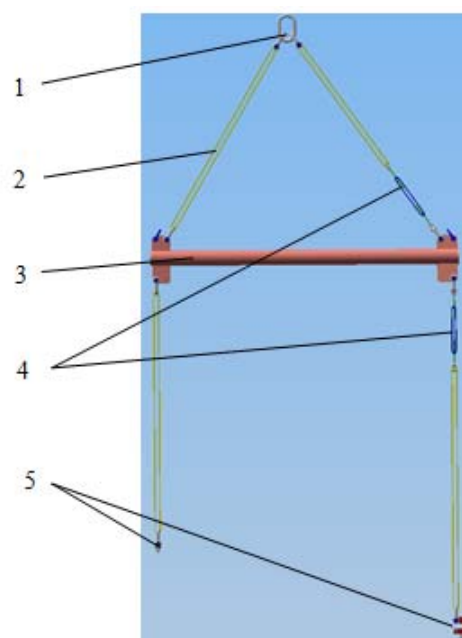

Fig. 3 The structure of the single-beam hoist: 1. hoisting ring, 2. hoisting sling, 3. hoisting beam, 4. adjustment screw, 5. connector

C. Method for Attitude Adjustment

The initial releasing attitude of the lunar lander is adjusted by

the attitude adjusting instrument, which consists of connector, pulling rope and adjustment screw, as shown in Fig. 4.

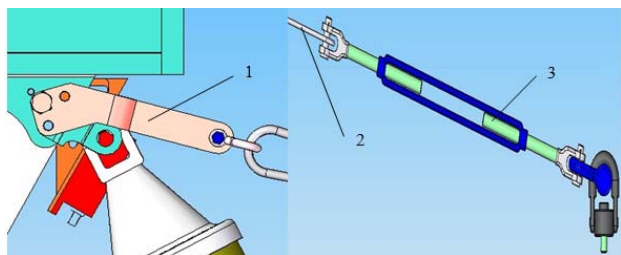

Fig. 4 Connection of attitude adjusting instrument: 1. connector, 2. pulling rope, 3. adjustment screw

Connect the lunar lander at right position with moveable large mass weights by two pulling ropes before the lander is hoisted. Pull the pulling ropes to prevent the lander from wobble during the hoisting process. Fix the weights at right position if the lander has been lifted to the required height. Then measure the heights of the four landing points and adjust the lengths of the pulling ropes by the adjustment screws to control the attitude of the lander.

D. Method for Spacing

The spacing function of the test equipment is realized by the spacing cables installed between the hoisting ring of the releasing device and the single-beam hoist. During the test, the end of the cable at the position of the hoisting ring of the releasing device can be regarded as a fixed point since the ring is fixed to the hook of crown block. The other end fall down together with the single-beam hoist and the lander after the releasing device is unlocked. The falling distance of the single-beam hoist is limited by the length of the spacing cable to prevent the single-beam hoist from keeping moving and colliding with the lander.

One of the key parameters is the length of the spacing cable. The theoretical length is:

$$D_t = H + \Delta H + L \quad (1)$$

where D_t is the theoretical length, H is the specified releasing height, ΔH is the max shrinking distance of the buffer and L is the height gap between the two ends of the spacing cable at the unlocking status.

Because of the pulling force of the spacing cable, the single-beam hoist will move back some distance at the landing moment of the lander, which will make the lander suffer corresponding force during the test and then influence the test result if the length of the spacing cable is equivalent to D_t .

Therefore additional length ΔL should be added to admit the single-beam hoist to move some distance after the lander landing on the surface and assure that collision or interference between the single-beam hoist and the lander should be avoided. Then actual length of the cable should be:

$$D_R = H + \Delta H + L + \Delta L \quad (2)$$

where D_R is the actual length of the spacing cable and ΔL is the vertical distance that the single-beam hoist can keep falling after the lander landing on the surface.

When the single-beam hoist at the lowest position, the hoisting slings for the lander hoisting purpose is relaxed and will wobble at some range thanks to the influences of the spacing cable and the hook of the crown block, since this wobble is mainly determined by the mass of the single-beam hoist and ΔL , a rational ΔL should be chose.

IV. LOAD TEST OF THE RELEASING DEVICE

A. Method

The releasing device is one of the key components for the lunar lander suspending, so the load test was conducted to verify its bearing capacity. The test was performed by the WE600 hydraulic universal testing machine and the MDAC automatic data collecting system. The strain gauge 1, 2, and 3 were located on the spring hook and the contacting surface of the lifting lug respectively, as shown in Fig. 5. We installed the spring hook and the lifting lug on the testing machine according to the test condition, initialized the strain measuring instrument and then uploaded the testing machine to 5000kg for data collection, as shown in Fig. 6.



Fig. 5 Allocation of the strain measuring points: 1. point 1, 2. point 2, 3. Point 3



Fig. 6 Load test of the releasing device

B. Results

After uploaded to 5000kg, there is no obvious deformation or crack on the releasing device surface. The spring hook normally performed for the manual unlocking function and slight indentations were found on the interface between the lifting lug and the spring hook. The strain measurement data and corresponding stress (calculated according to the formula:

$\sigma = E \times \varepsilon$, where σ is the stress, ε is the strain, and E is the elastic modulus equals to 210 GPa) is shown in Table I. The lifting lug and the spring hook were made from high-quality alloy steel and well material properties were obtained after heat treatment. The data of Table I show that the releasing device meets the safety requirement.

TABLE I
 STRAIN MEASUREMENT DATA AND STRESS CALCULATION DATA OF
 RELEASING DEVICE LOAD TEST

Location of the strain measuring points	Initial value of the testing instrument	Measured value of the strain ($\mu\varepsilon$)	Calculated value of the stress (Mpa)
Point 1	0	-1403.37	-294.708
Point 2	0	-1210.15	-254.132
Point 3	-0.529	-384.854	-80.819

V. LOAD TEST OF THE SINGLE-BEAM HOIST

A. Method

In order to verify the bearing capacity and reliability of the single beam hoist, the load test was conducted. MDAC automatic data collecting system is also used to collect and analyze the measured data. Before the test, seven strain gauges were located on the different position of the beam. And then hung the hoisting ring on the hook of crown block, connect the sling with the rail fixed on the ground through the press plate, as shown in Fig. 7. The upload should be 1.25 times the weight of the rated load. The crown block lifted the hoist until the upload arrived to the required value, then stopped lifting and

kept the status for 30 minutes, collected the measured data of the strain gauges every 5 minutes. Then lower the crown block to unload. The 10 times magnifying glass was used to check whether the hoist had any damage, and recorded the observation result.



Fig. 7 Load test of single-beam hoist

B. Results

After the load test, the observation result shows that the part of the equipment is in good condition and without any damage phenomenon such as obvious distortion, deformation or crack. The strain measurement data is shown in Table II and corresponding stress (calculated according to the formula: $\sigma = E \times \varepsilon$, where σ is the stress, ε is the strain, and E is the elastic modulus equals to 210 GPa) is shown in Table III. And the stress value is less than that of the material stress, and the deformation is also acceptable. The load test verifies the hoist meets the safety requirement.

TABLE II
 STRAIN MEASUREMENT DATA OF SINGLE-BEAM HOIST LOAD TEST

Measuring points	Initial value of the testing instrument	5min	10min	15min	20min	25min	30min
S1	-3.71	-36.55	-38.67	-40.79	-41.32	-41.32	-42.91
S2	0.53	-127.67	-127.67	-127.14	-128.2	-129.79	-129.79
S3	0	232.07	230.48	229.95	230.48	232.07	226.23
S4	3.72	-66.75	-94.29	-113.89	-129.26	-143.03	-156.8
S5	-3.18	-232.55	-230.96	-232.02	-232.55	-234.14	-232.55
S6	-0.53	-11.12	-11.65	-12.71	-13.77	-15.36	-18.01
S7	1.06	13.28	12.21	10.09	10.09	10.62	7.44

Unit: $\mu\varepsilon$

TABLE III
 STRESS CALCULATION DATA OF SINGLE-BEAM HOIST LOAD TEST

Measuring points	Initial value of the testing instrument	5min	10min	15min	20min	25min	30min
S1	-0.78	-7.68	-8.12	-8.57	-8.68	-8.68	-9.01
S2	0.11	-26.81	-26.81	-26.70	-26.92	-27.26	-27.26
S3	0	48.73	48.40	48.29	48.40	48.73	47.51
S4	0.78	-14.02	-19.80	-23.92	-27.14	-30.04	-32.93
S5	-0.67	-48.84	-48.50	-48.72	-48.84	-49.17	-48.84
S6	-0.11	-2.34	-2.45	-2.67	-2.89	-3.23	-3.78
S7	0.22	2.79	2.56	2.12	2.12	2.23	1.56

Unit: MPa

VI. COMPATIBILITY TEST

Compatibility test is conducted to verify the performance of the test system including the test equipment, the high speed video system and the impact-response testing system by the simulation lander.

A. Procedure

- 1) Assemble the releasing device, the single-beam hoist and the spacing cables, then hang them on the hook of the crown block, connect the connector with the simulation lander.
- 2) Connect the attitude adjusting instrument with the

simulation lander through the connector, and with the movable large mass weights through shackle, and make sure the pulling rope loosen, so the simulation lander can be hoisted without any resistance.

- 3) Lift simulation lander slowly about 0.84 meter above the ground, then tighten the pulling rope by moving the large mass weights to the right place.
- 4) Use the measure scale to measure the height of the simulation lander to the ground, then adjust the adjustment screw until the simulation attitude meets the requirement, and keeps the status for a while.
- 5) Press the button and unlock the release device, then the simulation lander fall down and impact on the ground.
- 6) The impact-response testing system collects the data when the simulation lander impacts on the ground.
- 7) Repeat the step 1 to step 6, and redo the test three times.

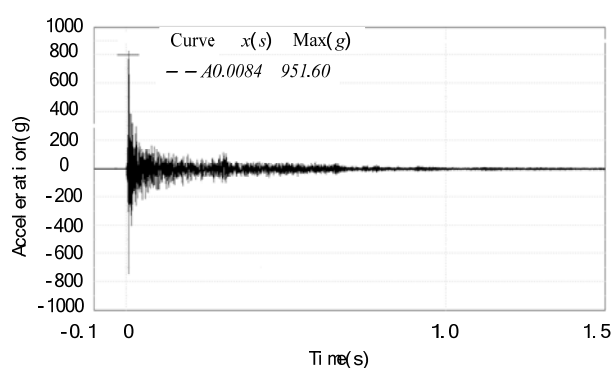

Fig. 8 Time-domain signal of impact response along Z-axis at measuring point 1 when the release altitude is 0.84 meter

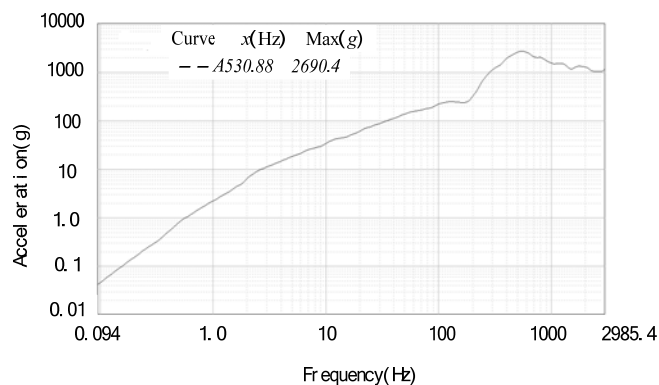

Fig. 9 Impact response spectrum along Z-axis at measuring point 1 when the release altitude is 0.84 meter

B. Results

The impact-response testing system adopts eight three-axis acceleration transducers and it has thirty two test channels. Some of the test data curves are shown in Figs. 8 and 9. The test result accords with the theoretical calculation. And it shows the unlocking response speed of the releasing device meets the initial releasing attitude and velocity requirement, the attitude adjusting instrument meets the initial attitude control requirement. The spacing cable is designed rational and it can effectively control the single beam hoist falling distance to

prevent it from colliding with the simulation lander and have no interference on the test. The whole performance and specification of the test system meet the requirement completely.

VII. CONCLUSION

Conclusion:

- 1) In order to realize the lunar lander landing-impact test, the test equipment with the characteristics of quick-response release and trouble-free interference is presented.
- 2) Load test has verified the releasing device and the single beam hoist safe and reliable.
- 3) Compatibility test has verified the reliability of the whole test system performance including the test equipment, the high speed video system, and the impact-response testing system.
- 4) The test equipment has been successfully applied to the lunar lander landing-impact test, and the test result shows it has the characteristics of easy operation, simple structure and universality. And it can be applied to different spacecraft impact test only by changing the hoist if necessary.

ACKNOWLEDGMENT

Xiaohuan Li thanks the support of this work by in Beijing institute of spacecraft environment engineering. And we also thank all my co-workers for the research and test.

REFERENCES

- [1] Liu Zhiqian, HuangChuanping. Review of the Development of Soft-landing Mechanisms for Lunar Explorations(J). Chinese Space Science and Technology, 2006, 26(1): 33
- [2] Hu Ya-bing, Sun Yi. Soft Lander of Lunar Lander. Aerospace Shanghai, 2010, 27(1): 43 ~ 44
- [3] Zhang Ze-mei, NieHong, et al. Investigation on the Landing-Impact Tests of the Lunar and the Key Technologies. Journal of Astronautics, 2011, 32(2): 268-269
- [4] Doiron, Harold H. Lunar Landing Dynamics Studies (C). Paper Present at Eleventh Manned Spacecraft Center Technical Symposium. NASA Manned Spacecraft Center. Houston, Texas, USA, Jan25, 1965.
- [5] William F R. Apollo Experience Report-Lunar Module Landing Gear Subsystem(R). NASA TND-6850, 1972
- [6] Li Chun, WuShitong, Deng Li. Research of Big Capacitance Date Recorder Used in Air-Drop Experiment. Spacecraft Recovery & Remote Sensing, 2006, 27(1): 7-8

Xiaohuan Li (March 16, 1980), postgraduate student, major in mechanical design and manufacturing, graduated from Harbin Institute of Technology in 2012, China.

She is an engineer engaged in design and research of Mechanical ground support equipment (MGSE) in Beijing institute of spacecraft environment engineering.