

# Design of Walking Beam Pendle Axle Suspension System

K. Arunachalam, P. Mannar Jawahar

**Abstract**—This paper deals with design of walking beam pendel axle suspension system. This axles and suspension systems are mainly required for transportation of heavy duty and Over Dimension Consignment (ODC) cargo, which is exceeding legal limit in terms of length, width and height. Presently, in Indian transportation industry, ODC movement growth rate has increased in transportation of bridge sections (pre-cast beams), transformers, heavy machineries, boilers, gas turbines, windmill blades etc. However, current Indian standard road transport vehicles are facing lot of service and maintenance issues due to non availability of suitable axle and suspension to carry the ODC cargoes. This in turn will lead to increased number of road accidents, bridge collapse and delayed deliveries, which finally result in higher operating cost. Understanding these requirements, this work was carried out. These axles and suspensions are designed for optimum self – weight with maximum payload carrying capacity with better road stability.

**Keywords**—Heavy duty trailer, Off-highway trucks, Over dimension cargo, Walking beam pendel axle suspension.

## I. INTRODUCTION

FOR the trade to exist, transportation of goods is very much important. When the automobile was first developed, the suspension systems were relatively simple mechanism to handle lightweight, low speed automobiles. They were adequate for that era. However, when the volume and size of the goods for transportation is large and heavy; usually trailers are used for transportation. This automobile application needs complex design to provide a perfect suspension system necessary to handle higher speed and heavier payload, off highway application and over dimension cargo of the modern vehicles. At present Indian standard road transport vehicle [1], [2] are facing lot of service and maintenance issues due to no availability of suitable axle and suspension to carry the ODC cargoes. The analysis of trailer requirement for sloshing fluid and granular cargo in transport vehicles has been carried out by [3].

Trailers are basically classified as semi trailer and independent trailer depending on the front-end support of the trailer. There are wide ranges of cargoes and hence wide ranges of trailer configuration are available. They includes flat bed trailer, low bed trailer, semi low bed trailer, well bed trailer, skeletal trailer, tipping trailer, tanker trailer, cement bulker trailer, coil carrying trailer, car transporter trailer, extendable trailer, self container handling trailer and steered

axle modular trailer etc. The chassis frames for each of the trailer configurations differ.

In standard mechanical axle and suspension system, the rear suspension assembly of the trailer mainly comprises of free-ended leaf springs. These free-ended leaves are fitted to the suspension hanger brackets namely front, middle and rear. These hanger brackets are welded below the trailer chassis frame. These axles are taken underneath or over and above the springs and held at their centre to the rear axle housing by U-bolts. The ends of the springs have no eyes and are arranged to slide freely over the bearings. These springs come into operations only when the load on the rear axle becomes too heavy.

Other accessories of a suspension assemblies like rigid torque arms are fitted first and then adjustable torque arms are fitted. The length of the adjustable torque arms is adjusted to maintain the same length of the rigid torque arm.

## II. ROLE OF TRAILER AXLES AND SUSPENSION SYSTEM

The principle requirements of a trailer axle and suspension system are as follows:

- To provide good ride handling performance and it requires the axle and suspension to have cross, vertical compliance providing chassis isolation and ensuring that the wheels follow the road profile with very little tyre load fluctuations.
- To ensure that steering control is maintained during maneuvering and it requires the wheels to be maintained in proper positional attitude with respect to the road surface
- To ensure that the vehicle responds favorably to control forces produced by the tyres as a result of longitudinal braking and accelerating forces, lateral cornering forces and braking and accelerating torques.
- To provide isolation from high frequency vibrations arising from tyre excitation and it requires appropriate isolation in suspension joints to prevent the transmission of the ‘road noise’ and roll over stability to the vehicle body.
- It will be seen that these requirements are virtually impossible to achieve simultaneously, which leads to have compromised design with less than ideal performance.

## III. WALKING BEAM PENDEL AXLE SUSPENSION

In contrast to the standard mechanical axle and suspension walking beam pendel axle does not include a separate axle, leaf spring and suspension hanger bracket [4]-[6].

Centre trunion and brackets are welded to the rear end of

K. Arunachalam and P. Mannar Jawahar are with the Department of Automobile Engineering, Anna University, MIT Campus, Chennai 600 044, India (e-mail: karunachalam@annauniv.edu, ponmannarjawahar@gmail.com).

the trailer chassis frame exactly with reference to the axle centre line. Balancing beam is hinged at its centre with reference to centre trunion bracket's centre. Tandem pendel axles are connected together using a balance beam which is mounted to the centre trunion. Two pendel axles are arranged adjacent to one another in a vehicle configuration. The single pended axle consists of a short axle beam and two hubs with brakes. The axle beam has a housing to accommodate the pivot bearings. The pendel axles can therefore be mounted on a link that is manufactured individually by vehicle manufacturers, thereby allowing the axle to pivot. Fig. 1 shows the CAD model of walking beam pendel axle suspension system.

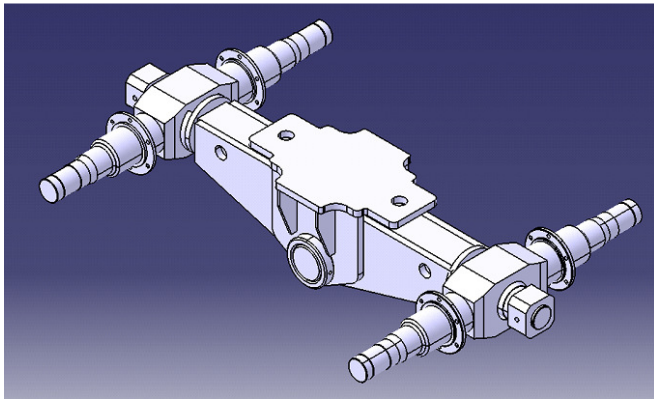

Fig. 1 CAD Model of walking beam pendel axle suspension system

The walking beam pendel axle suspension system mainly consists of following parts which are the key components and main load bearing members. The details of their function and design are listed below.

#### A. Centre Trunion

The centre trunion is used to connect centre trunion bracket and balancing beam. It is circular in shape. The end movement of the centre trunion is secured by means of head on both the sides. This centre trunion is subjected to bending moment and shear force. Fig. 2 (a) shows the centre trunion.

#### B. Centre Trunion Bracket

The centre trunion bracket is used to connect balancing beam and centre trunion. It acts as a central hinge which in turn provides 8 degree oscillation for the all wheel position. This centre trunion bracket subjected to bending moment. Fig. 2 (b) shows the centre trunion bracket.

#### C. Balancing Beam

The balancing beam holds the axles and provides 8 degree oscillation for the all wheel positions. It is hinged at its centre. This balancing beam can be treated as a simply supported beam. Load acts at centre of the beam and it is fixed on the both ends. Fig. 2 (c) shows the balancing beam.

#### D. Pendel Axle

The pendel axle holds all the wheels and provides 8 degree oscillation for the all wheel position. It is hinged at its centre.

This pendel axle acts as a simply supported beam. Load acts at centre of the beam and it is fixed on the both ends. Fig. 2 (d) shows the pendel axles.

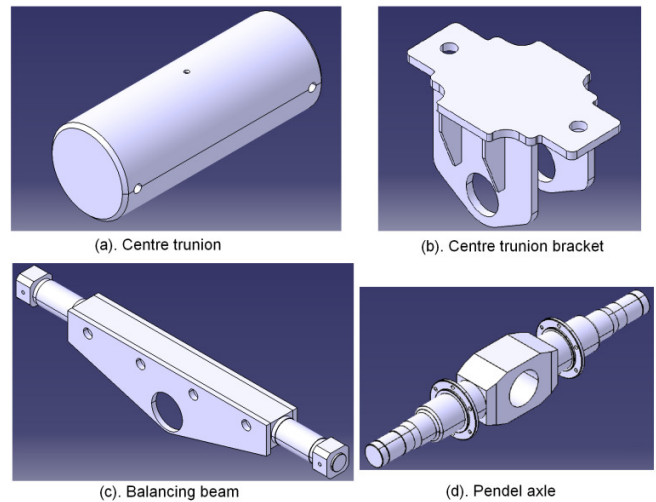

Fig. 2 Components of walking beam Pendel axle suspension system

Tandem pendel axles can cope with all irregularities in the carriage way by pivoting in both the lengthways and sideways axles of the vehicle [7], [8]. These pendel axles are most suitable for heavy duty applications with several rows of axle arrangement. The sideways pivoting movements of swinging bearings complement the suspension requirements. The balancing beam features ensures even axle load distribution for all axles and in turn to tyres. Finally, the safe operation is assured even in difficult road conditions and when negotiating steep loading ramps.

### IV. FINITE ELEMENT ANALYSIS OF PENDLE AXLE SUSPENSION SYSTEM

The static stress analysis for pendel axle suspension assembly along with their main components has been carried out to ensure all the stresses are within the limit for 7g loading conditions. Also analysis were carried out to optimize the design for various load conditions and ensure the displacement levels are within the limit for 7g loading conditions. Figs. 3 (a) and (b) shows the meshed model and boundary conditions with static load respectively. The finite element parameters are given in Table I.

The walking beam pendel axle is modeled in Catia using shell & beam elements. For analysis, the trailer rear axle load ( $48.8 \text{ T}/2 = 24.4 \text{ T}$ ) is applied as UDL to the base of the one centre trunion bracket which is attached to balancing beam which in turn is connected with Pendel axles on either sides. This walking beam pendel axle assembly is fixed at all wheel positions (two wheel track centre) to withstand axle load reactions. From the result it was found that the stresses are well within the specified limit. The stress distribution is plotted in Fig. 4. Fig. 5 shows the scale model.

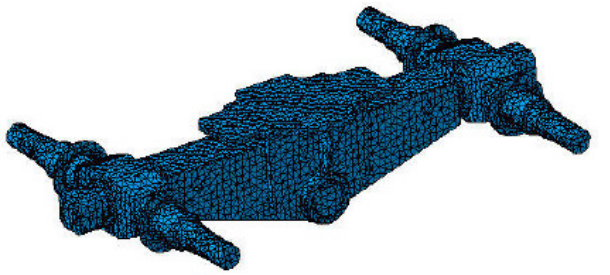

(a). Meshed Model

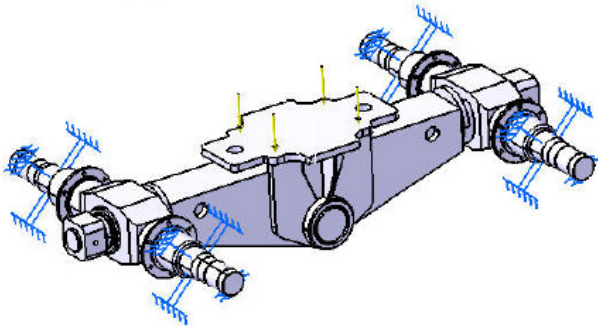

(b). Boundary Condition with Load Applied

Fig. 3 FE Model of walking beam pendle axle suspension system

TABLE I  
 FINITE ELEMENT PARAMETERS

Parameter	Value
Self Weight of Axle and Suspension	4000 Kg
Total Payload carrying capacity	48800 Kg
Material Considered	IS 2062
Yield Strength	2.5e+008 N/m <sup>2</sup>
No. of Nodes	13097
No. of Elements	47874
Young's modulus	2e+011N/m <sup>2</sup>
Poisson's ratio	0.266
Density	7860kg/m <sup>3</sup>
Coefficient of thermal expansion	1.17e-005/Kdeg
Yield strength	355 N/m <sup>2</sup>
Actual rear axle load	24.4 Tons
Load for FEA Static analysis	7 x 24.4 = 170.8 Tons
Boundary Condition	System is fixed at 4 locations, where the loads are transmitted through wheel centers

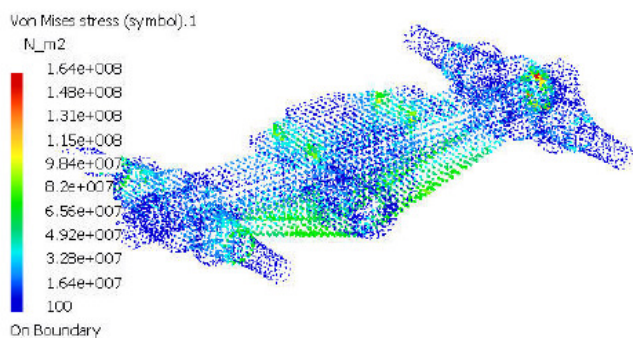

Fig. 4 Stress distribution on walking beam pendle axle suspension system

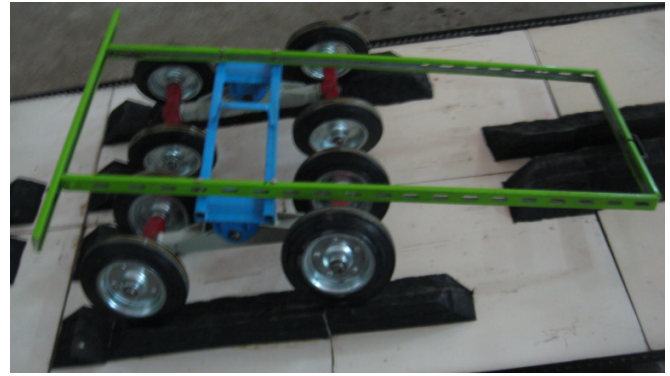

Fig. 5 Model of walking beam pendle axle suspension system

#### V. FEATURES AND BENEFITS

- Customised application and solid technology for toughest road conditions
- Reliable compact technology
- With swing axles heavy duty trailers can master any critical road surface and heavy ground.
- It has highly flexible and swinging bearings to compensate ground unevenness and ensure optimum ground contact all the time providing greater safety for driver and the payload.
- Easy and inexpensive maintenance even for heavy duty applications.
- Optimal design, better for mass production.
- Long vehicle travel and high pivoting movement is possible in this case.

#### VI. APPLICATIONS

- Over dimension cargo transportation (width of the trailer exceeds 2.6 mts).
- Heavy duty trailers where the trailer rear axle load exceeds 48 Tons.
- Off highway and rough roads.

#### VII. CONCLUSION AND FUTURE WORK

Walking beam pendel axle suspension system is designed in such a way that the rear axle can be able to load up to 48 Tonnes, with this new concept of axle and suspension integrated design. Further FEA analysis proves that this trailer suspension is very efficient for Over Dimension Cargo (ODC) and off highway applications, compared to conventional trailer axles and suspensions. Rear axle load of 48 Tonnes is shared by 16 wheels instead of 8 wheels as compare to conventional trailer axles and suspensions design. Hence, the improved stability, reduced tyre wear and better operating economics are ensured. A scale model of the proposed design has been made.

Lifting arrangement during unloaded condition for lifting one end of the axle is to be designed in order to improve the tyre life and to enhance operating economics.

#### REFERENCES

- [1] Ministry of Road Transport and Highways, Government of India, "Central Motor Vehicles Rules", 1989.

- [2] Indian Tyre Technical Advisory Committee, "ITTAC Standards," 2011.
- [3] Florian Fleissner, Alexandra Lehnarta, Peter Eberhard, "Dynamic simulation of sloshing fluid and granular cargo in transport vehicles", *Vehicle System Dynamics: International Journal of Vehicle Mechanics and Mobility*, vol. 48, no. 1, pp. 3–15, 2010.
- [4] Reggald E. Isley, "Walking beam suspension for tracked vehicle," *US Patent 6951260B1*, 2005.
- [5] Roger D. Jable, James B. Taylor, "Tandem-axle walking beam suspension," *US Patent 4699399A*, 1987.
- [6] Rymes John E, "Walking beam suspension," *US Patent 3386778A*, 1965.
- [7] Lin Li, Corina Sandu, "On the impact of cargo weight, vehicle parameters, and terrain characteristics on the prediction of traction for off-road vehicles," *Journal of Terramechanics*, vol. 44, no.3, pp. 221–238, 2007.
- [8] Herbert E. Cooper, Josef P. de Fazekas, E. Dallas Smith, "Trailer suspension apparatus," *US Patent 4878691*, 1988.