

Coordination between SC and SVC for Voltage Stability Improvement

Ali Reza Rajabi, Shahab Rashnoei, Mojtaba Hakimzadeh, Amir Habibi

Abstract—At any point of time, a power system operating condition should be stable, meeting various operational criteria and it should also be secure in the event of any credible contingency. Present day power systems are being operated closer to their stability limits due to economic and environmental constraints. Maintaining a stable and secure operation of a power system is therefore a very important and challenging issue. Voltage instability has been given much attention by power system researchers and planners in recent years, and is being regarded as one of the major sources of power system insecurity. Voltage instability phenomena are the ones in which the receiving end voltage decreases well below its normal value and does not come back even after setting restoring mechanisms such as VAR compensators, or continues to oscillate for lack of damping against the disturbances. Reactive power limit of power system is one of the major causes of voltage instability. This paper investigates the effects of coordinated series capacitors (SC) with static VAR compensators (SVC) on steady-state voltage stability of a power system. Also, the influence of the presence of series capacitor on static VAR compensator controller parameters and ratings required to stabilize load voltages at certain values are highlighted.

Keywords—Static VAR Compensator (SVC), Series Capacitor (SC), voltage stability, reactive power.

I. INTRODUCTION

POWER system stability may be defined as that property of a power system that enables it to remain in a state of operating equilibrium under normal operating conditions and to regain an acceptable state of equilibrium after being subjected to a disturbance [1].

Traditionally, the stability problem has been the rotor angle stability, maintaining the synchronous operation between two or more interconnected synchronous machines. Instability may also occur without loss of synchronism, in which case the concern is the control and stability of voltage. A criterion for voltage stability is that, at a given operating condition for every bus in the system, the bus voltage magnitude increases as the reactive power injection in the same bus is increased. A system is voltage unstable if, for at least one bus, the bus voltage magnitude decreases as the reactive power injection in the same bus is increased [2]. In other words, power system is voltage stable if voltages after disturbances are close to voltages at normal operating conditions. A power systems becomes unstable when voltages uncontrollably decrease due to outage of equipment, increment in load, decrement in production or in voltage control [3], [4].

Ali Reza Rajabi, Shahab Rashnoei, Mojtaba Hakimzadeh, and Amir Habibi are with Department of Electrical Engineering, Ahram Branch, Islamic Azad University, Ahram, Iran (e-mail: ar_rajabi@yahoo.com).

Even though the voltage stability is generally the local problem, the consequences of voltage instability may have a widespread impact. The result of this impact is voltage collapse, which results from a sequence of contingencies rather than from one particular disturbance. It leads to really low profiles of voltage in a major part of power system. The main factors causing voltage instability are [5], [6]:

- The inability of the power system to meet demands for reactive power in the heavily stressed system to keep voltage in the desired range
- Characteristics of the reactive power compensation devices
- Action and coordination of the voltage control devices
- Generator reactive power limits
- Load characteristics
- Parameters of transmission lines and transformers

These problems are becoming a more serious concern with the ever-increasing utilization and higher loading of existing transmission systems, particularly with increasing energy demands, and competitive generation and supply requirements. It is well established that enhancing the reactive power supplying ability of a power system by applying synchronous condensers, shunt and series capacitor banks, static compensators (STATCOM), static VAR compensators (SVCs), and other Flexible AC Transmission System (FACTS) controllers is effective in improving voltage stability. In recent years, the application of FACTS devices is a very effective solution to prevent a voltage instability and voltage collapse due to their fast and very flexible control. This study is devoted to the application of these SC for voltage stability enhancement. Coordination of such devices with SVC is proposed. The interrelations on their ratings and compensator control are illustrated. Use of only SC is firstly examined. Analysis of a large system containing devices is presented. However, the aim of this paper is to enhance steady-state voltage stability using SVC with SC.

II. STATIC VOLTAGE STABILITY

The voltage stability is divided into short-term and long-term voltage stability and it is load-driven. The distinction between long and short-term voltage stability is according to the time scale of load component dynamics. Short term voltage stability is characterized by components like induction motors, excitation of synchronous generators and devices like high voltage direct current (HVDC) or static VAR compensators (SVC). The time scale of short-term voltage stability is the same as rotor-angle stability. The distinction between these two phenomena is sometimes difficult, because voltage stability

does not always occur in its pure form and it goes hand in hand with rotor-angle stability [7]. However, the distinction between these two stabilities is necessary for understanding of the underlying causes of the problem in order to develop appropriate designs and operating procedures [3], [8]. The system enters the slower time frames after the short-term dynamics has come to end. The duration of long-term dynamics is up to several minutes.

A power system could utilize in safe manner when the occurrence of each possible contingency can not to exit system from normal work. Power system works in abnormal manner that variables exit from their allowed limit or the equilibrium between generation and consumption of energy spoils. Each event in power system would change the configuration of network that itself results in contraction of $V - \lambda$ curve and so decrease of MLP and its corresponding MWM. So for an ideal condition when system does not experience a contingency and all components work correctly, system can prepare MLP and Maximum Mega Watt Margin (MMWM). In a power system we encounter with too many contingencies that may results in overload in some of lines and/or bus voltages deviation from their allowed limit so that the position of the weakest bus may change. Fig. 1 shows $V - \lambda$ curve with MLP and Megawatt margin in appearing contingencies. The system may be operating at a stable equilibrium point but a contingency at maximum loading point may land unstable region or where there are no solutions to the system equations. The main reason for low voltage profile for some contingency and therefore smaller MWM is the insufficient reactive power in the vicinity of the low voltage buses [9], [10]. There are some severities contingencies with very low loading that are a small function of maximum loading, while for some other contingencies, the loading margin is near to its maximum. Contingencies ranking that are considered as necessary aspects of static voltage stability analysis, we can identify more critical contingencies to create preventive and improving strategies to avoid static voltage instability that occurs because of this sever contingency.

Open Science Index, Electrical and Computer Engineering Vol:8, No:9, 2014 publications.waset.org/9999347.pdf

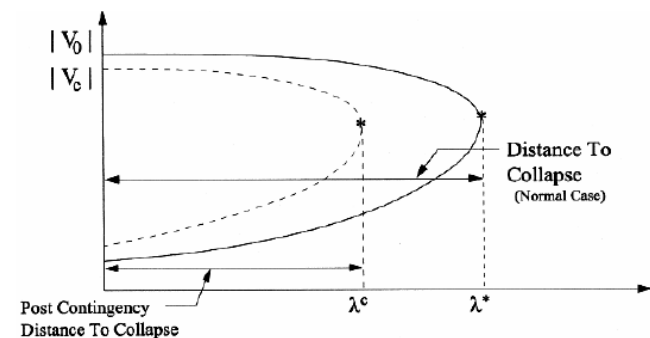

Fig. 1 Voltage collapse point at pre-contingency and post-contingency

III. STUDY SYSTEM

A large power system feeding a certain load of power ($P + jQ$) through a variable SC is used for this study and shown in Fig. 2. The system, at steady-state conditions, can be

represented by its Thevenin's equivalent seen from node 5 as shown in Fig. 3. Data used in this study: $R_s = 0.0816$ p.u., $X_s = 0.3$ p.u., $V_r = 0.99$ p.u., $V_s = 1.004$ p.u.

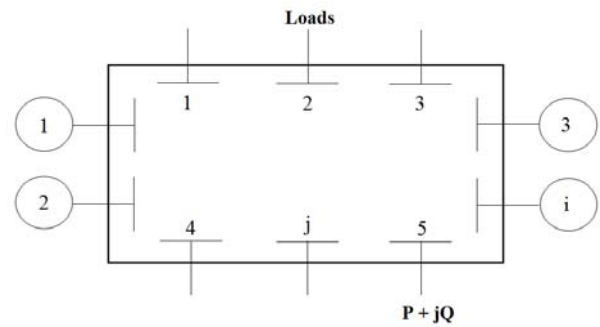

Fig. 2 Large power system

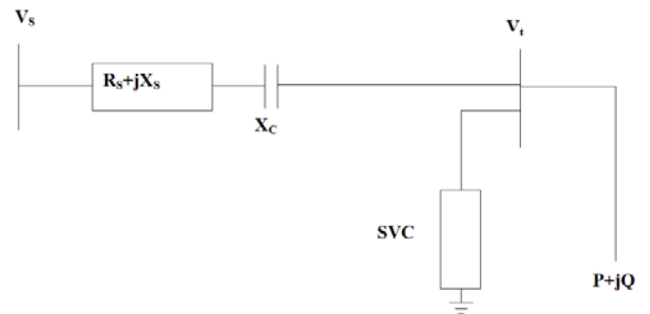

Fig. 3 Thevenin's equivalent system

A thyristor-controlled reactor/ fixed capacitor (TCR/FC) type is used [11]. Its control system consists of a measuring circuit for measuring its terminal voltage V_T , a regulator with reference voltage and a firing circuit which generates gating pulses in order to command variable thyristor currents I_L , through the fixed reactor reactance X_L . This variable current draws variable reactive power ($I_L^2 X_L$) which corresponds to variable virtual reactance of susceptance B_L given by: $(V_T^2 B_c = I_L^2 X_L)$. Together with the fixed capacitive reactive power ($I_c^2 X_c$), this forms the complete variable inductive or capacitive reactive power of that static compensator [12]. Fig. 4 shows the transfer function of that power system provided by SC and a SVC. Fig. 5 shows the simplified transfer function block diagram of that system with combined SC and SVC.

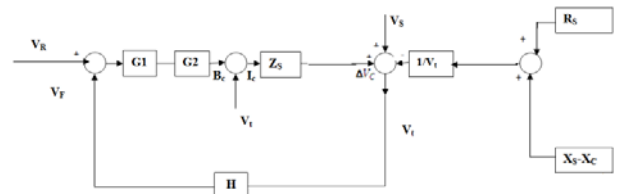

Fig. 4 Block diagram of a SVC and SC

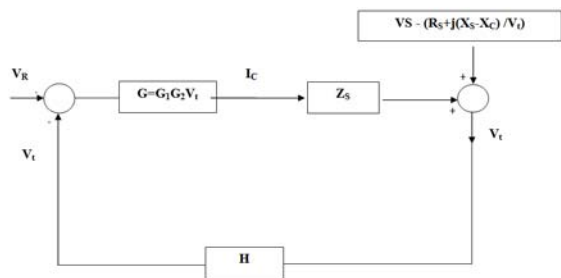

Fig. 5 Simplified transfer function block diagram of SVC and SC

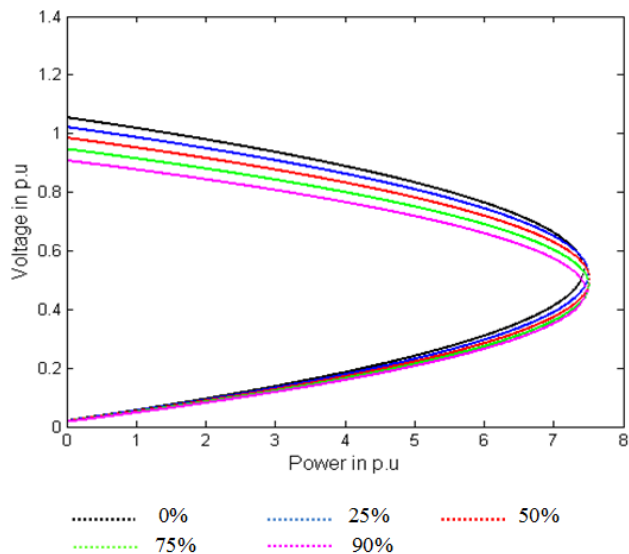

Fig. 6 P-V curve with different series compensation (0-90%), with constant Q and with $G=0.0$

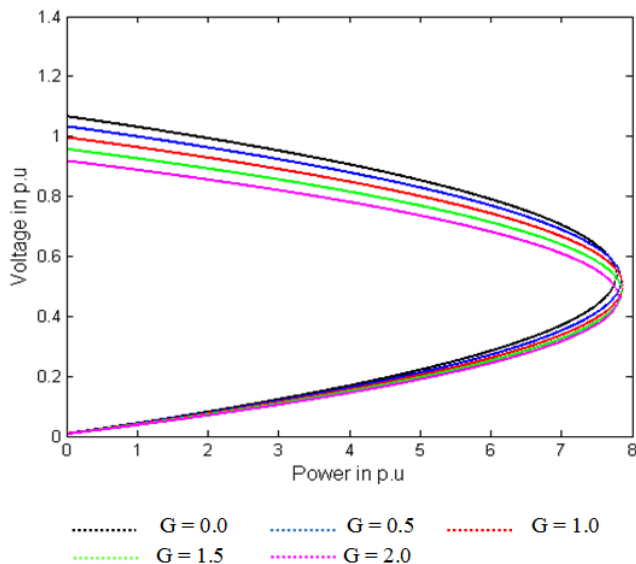

Fig. 7 P-V curve with different G and $X_c=0.0781$ (25% Series Compensation)

IV. SIMULATION RESULTS

A. PV Curve with the Presence of SC and SVC

The famous curve of the Voltage/Power relation is plotted. Having a load of constant power factor, the voltage is plotted against the load VA power, in the presence of different SC compensation percentages (0, 25, 50, 75, 90%) in Fig. 6 and different G and $X_c=0.0781$ in Fig. 7.

As we can see in these plots that by the use of Capacitor in the circuit, the peak-load voltage can be increased by increasing the series compensation. Fig. 8 shows that maximum possible critical power increases with the increase of SC series compensation percentage.

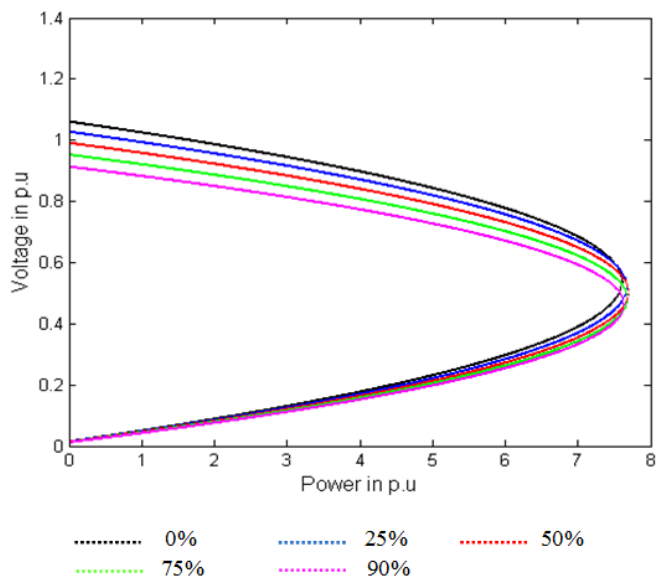

Fig. 8 P-V curve with different SVC gains (0.0-2.5), with constant Q and with $X_c= 0.0781$

As we can see in these three plots that by the use of Capacitor in the circuit, the peak-load voltage can be increased by increasing the capacitor rating. Table I, shows the maximum load power corresponding to various values of SVC controller gains.

TABLE I
 MAXIMUM LOAD POWER AS AFFECTED BY COMPENSATOR CONTROLLER GAINS

Compensator Gain(G)	Maximum Power
0.0	2.39
2.5	4.83
5.0	7.3
10.0	12.4

V. CONCLUSION

SC can enhance steady-state voltage stabilities by decreasing the effective series reactance of systems and increasing the load node short-circuits levels. Certain compensation percentages should be avoided while other percentages are recommended. By using the series capacitor with the SVC the Peak-load voltage can significantly be increased. With network elements

SVC ratings are obtained and savings are evaluated with and without SC.

REFERENCES

- [1] M. Crow, : *Computational Methods for Electric Power Systems*, CRC Press, ISBN 0-8493-1352-X, 2002.
- [2] P. Kundur, : *Power System Stability and Control*. McGraw-Hill, ISBN 0-07-035958-X, 1994.
- [3] M. Larsson, : *Coordinated Voltage Control in Electric Power System*. Doctoral dissertation. Lund University: 2002.
- [4] B.L. Guedes, Renato, F.C. Alberto, Luis, G. Bretas, Newton.: Power System Low-Voltage Solutions Using an Auxiliary Gradient System for Voltage Collapse Purposes. *IEEE Transactions on Power Systems*: 2007.
- [5] L.C.P. Da Silva, V.F. da Costa, , W. Xu, , Assesment of generator impact on power transfer capability using modal participation factors, *IEE Proceedings Gener.-Transm.- Distrib.*, Vol 149, No.5, 2002.
- [6] P. Kundur, J. Paserba, V. Ajarapu, G. Andersson, A. Bose, C. Canizares, N. Hatziaargyriou, D. Hill, C. Taylor, T.V. Cutsem Definition and Classification of Power System Stability, *IEEE/CIGRE, Joint Task Force on Stability terms and definitions: Electra*, no.208, 2003.
- [7] B. H. Lee and K. Y. Lee, "Dynamic and Static Voltage Stability Enhancement of Power Systems," *IEEE Transactions on Power Systems*, Vol. 8, No. 1, pp. 231-238, 2001.
- [8] Cigre 95 TP108, *FACTS Overview*, IEEE Power Engineering Society, 1995.
- [9] C. A. Cañizares, "Power Flow and Transient Stability Models of FACTS Controllers for Voltage and Angle Stability Studies," *Proceedings of the 2000 IEEE-PES Winter Meeting*, Singapore, January 2003.
- [10] A. Sode-Yome and N. Mithulananthan, "Comparison of shunt capacitor, SVC and STATCOM in static voltage stability margin enhancement," *International Journal of Electrical Engineering Education*, UMIST, Vol. 41, No. 3, July 2009.
- [11] D. Thukaram, A. Lomi, "Selection of Static VAR Compensator Location and Size for System Voltage Stability Improvement," *Electrical Power Systems Research*, Vol. 54, pp. 139-150, 2000.
- [12] A. R. Messina, M.A. Perez, E. Hernandez, "Coordinated application of FACTS devices to enhance steady-state voltage stability," *Electrical Power and Energy Systems*, Vol. 25, pp. 259-267, 2007.