

Novel Use of a Quality Assurance Tool for Integrating Technology to HSE

Ragi Poyyara, Vivek V., Ashish Khaparde

Abstract—The product development process (PDP) in the Technology group plays a very important role in the launch of any product. While a manufacturing process encourages the use of certain measures to reduce health, safety and environmental (HSE) risks on the shop floor, the PDP concentrates on the use of Geometric Dimensioning and Tolerancing (GD&T) to develop a flawless design. Furthermore, PDP distributes and coordinates activities between different departments such as marketing, purchasing, and manufacturing. However, it is seldom realized that PDP makes a significant contribution to developing a product that reduces HSE risks by encouraging the Technology group to use effective GD&T.

The GD&T is a precise communication tool that uses a set of symbols, rules, and definitions to mathematically define parts to be manufactured. It is a quality assurance method widely used in the oil and gas sector. Traditionally it is used to ensure the interchangeability of a part without affecting its form, fit, and function. Parts that do not meet these requirements are rejected during quality audits.

This paper discusses how the Technology group integrates this quality assurance tool into the PDP and how the tool plays a major role in helping the HSE department in its goal towards eliminating HSE incidents. The PDP involves a thorough risk assessment and establishes a method to address those risks during the design stage. An illustration shows how GD&T helped reduce safety risks by ergonomically improving assembling operations. A brief discussion explains how tolerances provided on a part help prevent finger injury. This tool has equipped Technology to produce fixtures, which are used daily in operations as well as manufacturing. By applying GD&T to create good fits, HSE risks are mitigated for operating personnel. Both customers and service providers benefit from reduced safety risks.

Keywords—HSE, PDP, GD&T, risks.

I. INTRODUCTION

HEALTH, Safety, and Environment (HSE) management systems (a statutory requirement in the oil and gas industry) are constantly evolving with lessons learnt from near misses, incidents, and accidents. Nevertheless, accidents still happen often leading to a new aspect of a lesson learnt, or due to the repetition of a mistake, leading to a similar incident that could have been easily prevented [1].

According to the ASM (Abnormal Situation Management) consortium, the three principal sources of abnormal situations are people, equipment, and processes [2].

The ASM consortium is a research and development

Ragi Poyyara is with Halliburton Technology Centre, Pune, Maharashtra, India (e-mail: ragi.poyyara@halliburton.com).

Vivek V. is with Halliburton offshore India Ltd. Mumbai, Maharashtra, India (e-mail: vivek.v@halliburton.com)

Ashish Khaparde is with Halliburton Completions Manufacturing Ltd, Singapore. (e-mail: ashish.khaparde@halliburton.com)

consortium founded in 1994 by Honeywell to identify problems facing industrial plant operations during abnormal conditions, and to develop solution concepts [2]. These principal sources of abnormalities, i.e. unwarranted and unwanted human actions, degraded or failed equipment, and process complexity are indeed—universally—the very reasons behind any incident or accident. As long as people, equipment, and processes are involved in an activity, HSE risks are invariably present (Fig. 1).

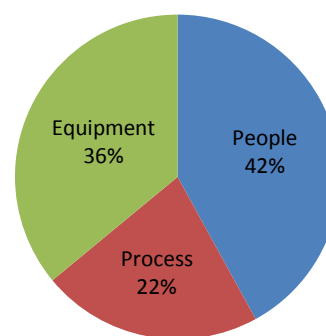

Fig. 1 Causes of Abnormal Situations as per ASM

An effective HSE management system forms an integral part of every successful management initiative [3]. It involves commitment from senior management to personally lead the effort and includes participation by all levels of employees in a company's drive to ZERO accidents [3]. Hence, in a successful HSE management system, safety of self, co-workers, and the plant is the primary responsibility of every individual in the organization irrespective of their field of work. This paper discusses the role of the Technology Group in HSE management and HSE risk mitigation.

II. PROACTIVE VS. REACTIVE RISK MITIGATION

Risk management has increasingly become recognized as an integral part of an effective HSE management system. Risk mitigation can be reactive or proactive. Proper risk management implies control of future events and is proactive, not reactive. Proper risk management will reduce not only the likelihood of an event occurring, but also the magnitude of its impact. The Technology Group (using GD&T, see Fig. 2) plays a significant role in proactive risk management by investigating identified HSE risks and determining the best solution during the design phase of the product [4].

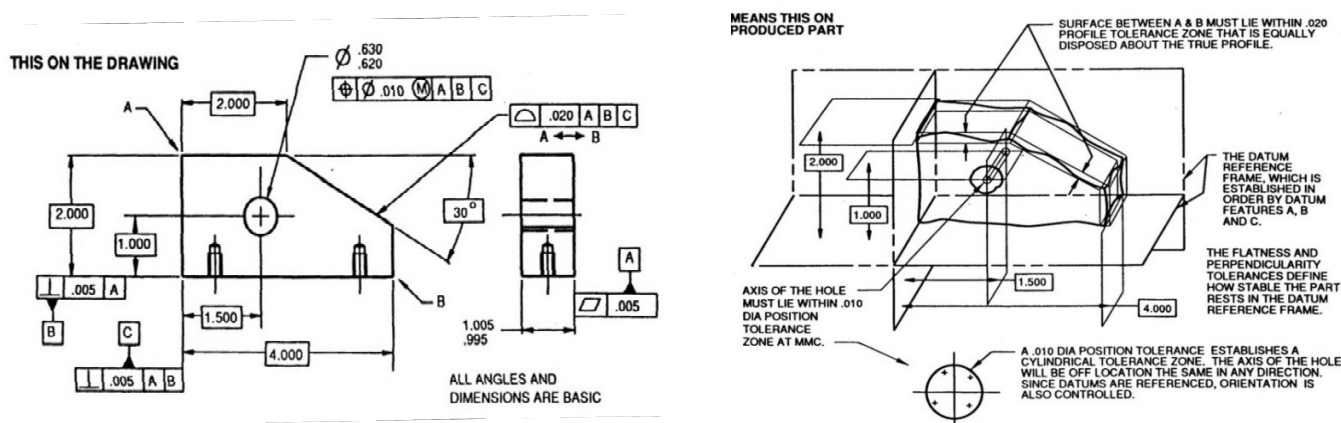

Fig. 2 GD&T applied to a simple angle block [9]

An effective Technology group uses PDP (Product Development Process) to successfully introduce new products to the market. Risk assessment and mitigation is an important checkpoint in PDP.

III. THE PDP PROCESS

PDP is a process that transforms technical ideas or market needs and opportunities into a new product and on to the market. A creative and iterative set of steps and phases converts ideas into saleable products and/or services. It includes strategy, organization, concept generation, product, and marketing plan creation and evaluation, and the commercialization of a new product [5].

PDP distributes and coordinates activities between different departments. PDP helps in developing products in multi-functional teams with early and active participation from manufacturing, marketing (and even customers), finance, industrial designers, quality, service, purchasing, vendors, regulation compliance specialists, and lawyers. The team works together to design for functionality, as well as to optimize cost, delivery, quality, reliability, ease of assembly, testability, ease of service, shipping, human factors, styling, safety, customization, expandability, and various regulatory and environmental compliance [6].

In the Technology Group, every stage of PDP mandates several checkpoints about design for interchangeability and its contribution to HSE risk mitigation, which we will discuss in this paper. Several engineering tools form a part of the larger effort of PDP. The Geometric Dimensioning and Tolerancing (GD&T) is one such tool used to ascertain design for interchangeability. Use of GD&T within a well-defined product development effort can identify a bad design before it results in a lot of needless effort and expensive parts [7].

IV. GEOMETRIC DIMENSIONING AND TOLERANCING

Product variation and imperfection from the manufacturing process are inevitable. To minimize such imperfections, tolerances are used in engineering drawings. The tolerances in a drawing tell how much variance or imperfection is allowable before the part must be considered unfit for use.

The GD&T is a precise communication tool that uses a set of symbols, rules, and definitions to mathematically define parts to be manufactured. It is a means of dimensioning and tolerancing a drawing that considers the function of the part and how this part functions with related parts. It is an engineering design drawing language and a functional production and inspection technique [8].

The American Society of Mechanical Engineering and the International Organization for Standardization have worked towards creating a system for part design that can be understood and used around the world [8]. ASME Y14.5M and ISO 1101 are the international standards that define the GD&T standard.

GD&T thereby assists in inspection and is used as a quality assurance tool. By emphasizing how features relate to each other, manufacturers can better control the design, fit, and function of parts. This process ensures that good parts pass inspection and bad parts are caught and rejected before they reach the customer.

This system uses standard symbols to indicate tolerances based on a feature's geometry. GD&T symbols are known universally as a way to specify requirements without using notes or words on the drawing. A typical example is given in Fig. 2. Fig. 3 shows common tolerance symbols.

TYPE OF TOLERANCE	CHARACTERISTIC	SYMBOL	DATUM REFERENCE
FORM	STRAIGHTNESS		INDIVIDUAL
	FLATNESS		
	CIRCULARITY (ROUNDNESS)		
	CYLINDRICITY		
PROFILE	PROFILE OF A LINE		INDIVIDUAL OR RELATED
	PROFILE OF A SURFACE		
ORIENTATION	ANGULARITY		RELATED
	PERPENDICULARITY		
	PARALLELISM		
LOCATION	POSITION		RELATED
	CONCENTRICITY		
	SYMMETRY		
RUNOUT	CIRCULAR RUNOUT		RELATED
	TOTAL RUNOUT		

Fig. 3 Common Tolerance Symbols

There are several advantages in using this tool [8]:

- 1) It saves money.
- 2) Provides for maximum producibility of a part through maximum production tolerances.
- 3) Ensures that design dimensional and tolerance requirements, as they relate to actual function, are specifically stated and thus carried out.
- 4) Adapts to, and assists, computerization techniques in design and manufacturing.
- 5) Ensures interchangeability of mating parts at assembly.
- 6) Provides uniformity and convenience in drawing delineation and interpretation thereby reducing controversy and guesswork.

However, it is seldom realized that GD&T as part of the larger effort of PDP makes a significant contribution to developing a product in a way that reduces HSE risks.

V. MITIGATING HSE RISKS USING GD&T

A down-hole mud motor is comprised of a driveshaft (Fig. 4) and a lower bearing sub (Fig. 5) coupled by polygonal flats for torque transmission. To ensure perfect torque transmission, the tolerances on the driveshaft polygonal flats and the bearing polygonal flats must be tight enough to avoid any play during torque transmission.

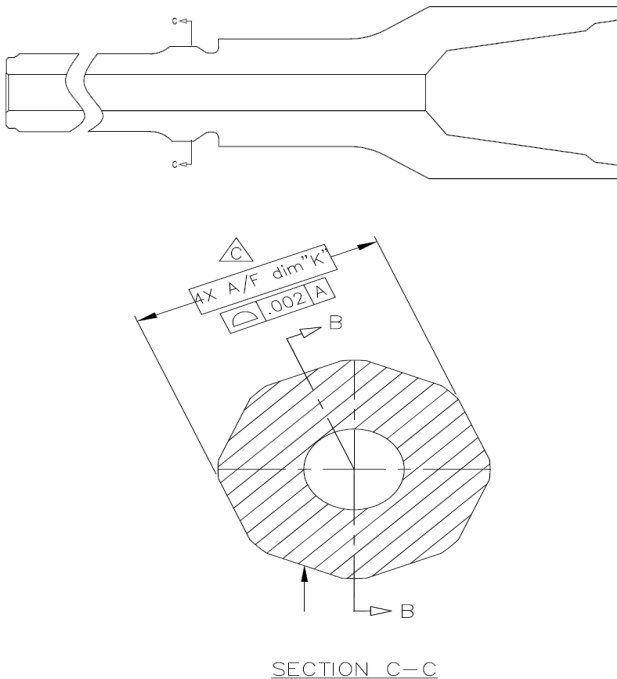

Fig. 4 Drive shaft with polygonal cut on outside diameter at section CC

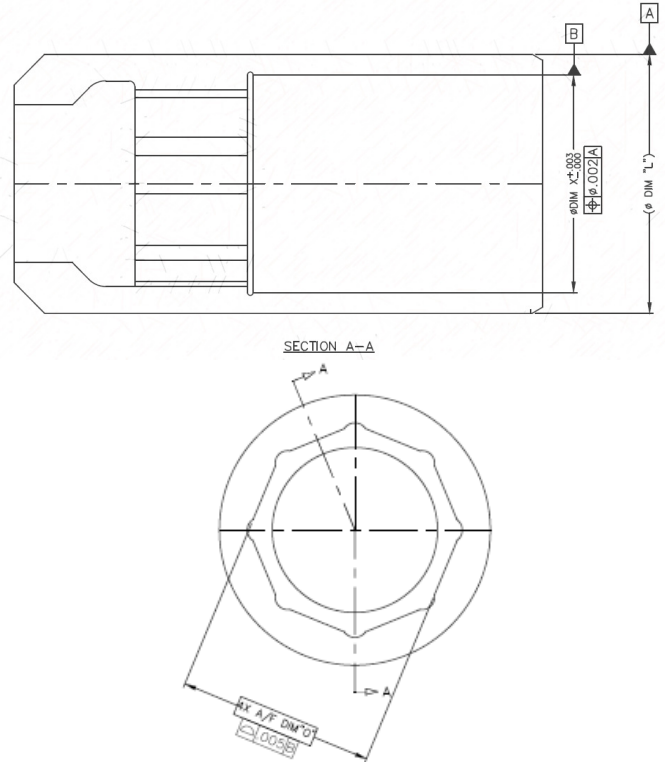

Fig. 5 Lower bearing sub with polygon cut in the internal diameter

A slight deviation from the specified tolerance makes assembly of the mating parts difficult. In addition, if the part feature is out of control, assembly can become difficult.

A correct design would be to specify the datum and position tolerance of 0.002 on the ID of the bearing with respect to its OD, which is machined first in the operation. Thus, the driveshaft polygon is given a profile tolerance of 0.002 to control the profile of the polygon flat on its OD and the bearing has a profile tolerance of 0.005 on the polygonal face. Once these feature tolerances are mentioned on the drawing, the quality control/assurance team certifies that the parts are manufactured within the tolerance limits and are good to use. Thus the drawing itself ensures ease in assembling the components without the need to hammer them and thereby preventing any hand injury. This scenario applies to all tight-fit mating components.

While using M/LWD (Measuring/Logging While Drilling) tools during drilling, the internal components of the tool need to be placed into the rigid collar, which provides a protective covering over the tools. If done by hand, insertion of the complex internal components into the collar can pose a serious threat to the hand and body safety of the operating personnel. To assist the personnel during this process, handling tools have been made available to create a safer working environment. The design of these handling tools provides a good example of the perfect application of GD&T on a platform to enhance safety.

The collar is cylindrical. The internal components (called the fish-neck) which need to be lowered onto the collar are also roughly cylindrical to enable the smooth flow of mud.

The design as shown in Fig. 6 has mandrels which can grab on to the internal diameter of the fish-neck. The whole arrangement can then be lowered into the collar and placed at the designated depth. Once the required setting is achieved an internal mechanism causes the mandrels to retract and the tools can be pulled out.

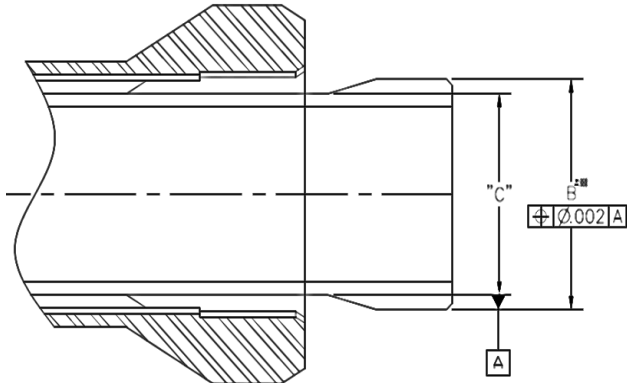

Fig. 6 Mandrel

If the fish-neck and handling tools do not meet the specified dimensions, the handling tool will not properly engage and lock into the fish-neck causing a potential risk of falling objects. By application of correct tolerances on these parts we can ensure that the handling tool can grab on to the internal ID of the fish-neck. In this case, by applying a size tolerance of ± 0.006 onto dimension C and a positional tolerance of 0.002 (Fig. 3) we can make certain that the mandrel can engage on to the fish-neck during operations thereby preventing the risk of falling objects. In a larger picture, this small feature tolerance value is the key to ensuring a safe working environment. This is just one of many examples of how a small tolerance value can play a very big role in the work environment from an HSE perspective.

VI. CONCLUSION

This paper reviews the use of GD&T from a different perspective. It discusses how a GD&T when applied on manufacturing drawings prevents HSE risks such as hand injury and falling objects. Designing a part while considering the sequence of machining and assembly helps the designer visualize the whole process and avoid actions, which poses HSE risks. We have seen that providing position and profile tolerances improves the ergonomics of a part thereby creating ease in assembly.

REFERENCES

- [1] AchalMisra, "Human Factors in HSE Performance" Abu Dhabi International Petroleum Conference and Exhibition, 11-14th November, 2012.
- [2] www.asmconsortium.net dated 8th February 2013.
- [3] Atef Ahmed Madkour, "Operating Company's (HSE) management System (Guidelines, Practices & Results)" SPE International Conference on Health, Safety and Environment in Oil and Gas exploration and Production, 26-28 June, Stavanger, Norway, 2000.

- [4] Hafeez Syed, Vivek V, "Paradigm of Integrating Technology to Reach Zero Safety Risks" SPE Americas E&P Health, Safety and Environmental Conference, 18-20 March, Galveston, Texas USA, 2013.
- [5] Jan Carel Diehl, New Product Development.
- [6] www.design4manufacturability.com/DFM_article.htm dated 22nd Feb 2013.
- [7] www.machinedesign.com/article/avoiding-design-problem-with-geometric-dimensioning-and-tolerancing-0303 dated 27th Feb 2013.
- [8] www.audit.edu/course_documents/Manufacturing_Skills/GD&T/Fundamental_of_GDandT dated 27th Feb 2013.
- [9] www.engr.sjsu.edu/rellis/courses/ME250/.../GDT%20tutorial.ppt dated 27th Feb 2013.