

Efficient Use of Energy through Incorporation of a Gas Turbine in Methanol Plant

M. Azadi, N. Tahouni, M. H. Panjeshahi

Abstract—A techno-economic evaluation for efficient use of energy in a large scale industrial plant of methanol is carried out. This assessment is based on integration of a gas turbine with an existing plant of methanol in which the outlet gas products of exothermic reactor is expanded to power generation. Also, it is decided that methanol production rate is constant through addition of power generation system to the existing methanol plant. Having incorporated a gas turbine with the existing plant, the economic results showed total investment of MUSD 16.9, energy saving of 3.6 MUSD/yr with payback period of approximately 4.7 years.

Keywords—Energy saving, Gas turbine, Methanol, Power generation.

I. INTRODUCTION

NOWADAYS, various chemical processes are studied to check the feasibility of incorporation of gas turbine into the process owing to efficient use of energy. There are exothermic reactions in many industries, which release significant amount of energy. The energy liberated can be used elsewhere for heating of other parts of process and/or for power generation. Methanol plant is one of the most energy intensive processes in petrochemical industry. Application of energy conversion systems, such as integration of a gas turbine with this process, can result in better heat recovery through the methanol production plant.

One of the latest achievements in methanol plant evaluation from energy viewpoint is the result obtained by Narvaez et al. They compared fresh synthesis gas consumption and catalyst activity between methanol power polygeneration system and stand-alone plants [1]. In another survey, Soltanieh et al. analyzed an integrated system for coproduction of methanol and power techno-economically. The aim of their survey was development of a non-emission integrated plant for methanol and electricity using renewable sources of energy [2]. A methanol production plant was evaluated by KovacKarlj after being integrated with a gas turbine. The methodology of her study was based on a NLP formulation to find an optimum energy targeting value for process integration [3]. A conventional ammonia production plant was considered in survey conducted by Sahafzadeh et al. The goal of their

study was reduction in exergy losses by integration of a gas turbine with existing process as well as achievement of minimum energy requirement via pinch technology concepts [4].

Axelsson et al. developed a systematic methodology for combination of heat and power cogeneration and gas turbine integration based on pinch analysis [5]. Kalitventzeff et al. have considered the application of a gas turbine in an ammonia production plant. They revised the major principles of energy integration, such as combined production of heat and power for an existing process taking into account of overall energy efficiency [6]. A process for synthesis of ethane from methane has been evaluated by Janssen et al. In the process, the exothermic catalytic reaction occurs in a gas turbine combustion chamber. Combustion products are expanded in the gas turbine to drive the methane and combustion air compressor [7].

Agee et al. studied a synthesis gas production system including a gas turbine with an auto-thermal reformer between the compressor and expander. Combination of steam reforming and partial oxidation is used in the reformer. The heat for the endothermic steam reforming reaction is supplied by exothermic heat of the partial oxidation. The reformer product is synthesis gas, which is considered as the combustor for the gas turbine [8].

Related to the subject, two theoretical case studies have been developed, namely a study on turbo expander integration in phthalic anhydride production by Perold et al. [9] and a study on methanol production by Greeff et al. [10]. Both these case studies indicated a meaningful scope for energy saving in production of typical chemicals in the integrated processes in comparison with the conventional processes [11].

In this paper, a methanol production plant is chosen and the effects of integration of a gas turbine with methanol reactor product are investigated.

II. METHODOLOGY

In all petrochemical industries, there is a great demand of heating, cooling and shaft work. To compensate the demands, various approaches have been taken into account economically and environmentally. One of these approaches is development of a co-production system. A co-production system produces different chemicals as well as various types of energy. A co-production system is typically shown in Fig. 1.

M. Azadi is MSc Student with the School of Chemical Engineering, College of Engineering, University of Tehran, Iran (e-mail: marjan_azadi@yahoo.com).

N. Tahouni is Assistant Professor with the School of Chemical Engineering, College of Engineering, University of Tehran, Iran (phone: 98-21-66957788; fax: 98-21-66957784; e-mail: ntahuni@ut.ac.ir).

M. H. Panjeshahi is Professor with the School of Chemical Engineering, College of Engineering, University of Tehran, Iran (e-mail: mhpanj@ut.ac.ir).

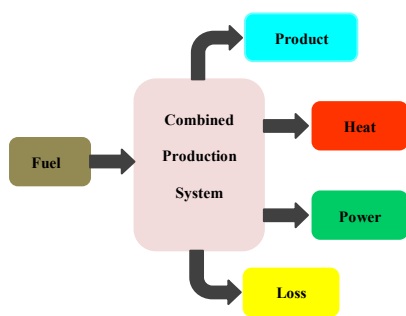

Fig. 1 A typical co-production system

Methanol plant integrated with a gas turbine is an example of a co-production plant with methanol and power products. Concept of power generation from reaction heat can be simply implied by expansion of process gas in a chemical production cycle. Chemical production plant, mostly operate in cycle in order to reach high conversion of reactants. As can be seen in Fig.2 the chemical synthesis cycles mainly consists of feed and recycle gas compressors, reactors, heat exchangers, and separators. If the reaction takes place exothermically, the reaction heat should be carried away from reaction chamber due to instability of reaction mixture at high temperature.

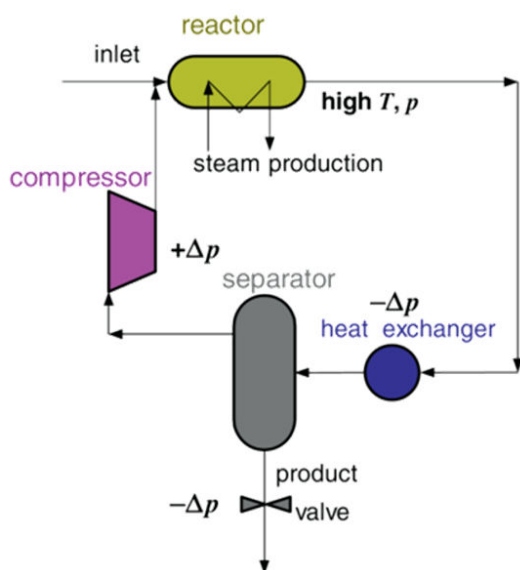

Fig. 2 Chemical production exothermic cycle

One way for sufficient use of reaction heat is expansion of reactor outlet product in a gas turbine for power generation. When a gas phase exothermic reaction occurs at high pressure in an adiabatic reactor, enthalpy rise of reaction mixture leads to increasing temperature of reactor outlet stream. Hence, available high pressure heat of reaction can be applied to produce shaft work through incorporation of a gas turbine in the existing process. Gas turbine integrated chemical production cycle is shown in Fig. 3. Based on this figure, there is structural analogy in gas turbine integrated chemical production cycle and Brayton power cycle and process fluid

passes through the same path as Brayton cycle working fluid does. Thus, exothermic reaction chamber performs the combustion chamber role in Brayton cycle. Moreover, cooling and separation of process fluid acts as the heat rejection step in Brayton cycle.

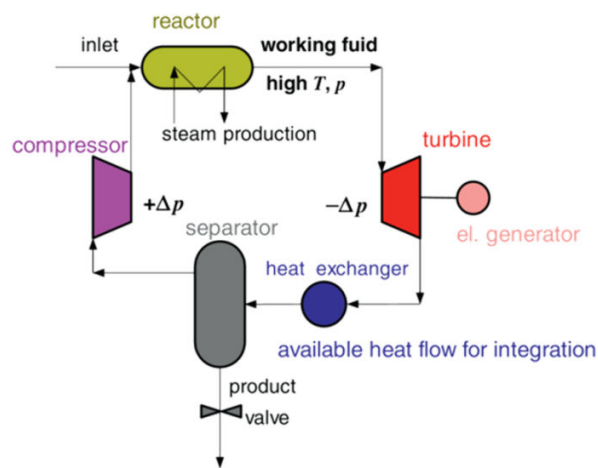

Fig. 3 Chemical production exothermic cycle integrated with gas turbine

III. CASE STUDY – EXISTING PROCESS

The suggested scheme for integration of a gas turbine has been applied in an existing methanol plant having a production capacity of 5000 MTPD pure methanol (licensed by Lurgi, Frankfurt, Germany).

The six steps to produce methanol are:

- Sulphur Removal
- Pre-Reforming
- Steam-Reforming
- Autothermal Reforming
- Methanol Synthesis
- Methanol Purification (Distillation)

In methanol synthesis section methanol is produced from synthesis gas (hydrogen, carbon monoxide and very often some carbon dioxide) in the presence of a highly selective copper based catalyst. The three main reactions are taken place in methanol synthesis reactor as follows:

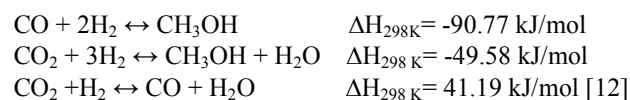

In the synthesis section the feed stream which mainly consists of synthesis gas is mixed with the hydrogen stream from PSA unit, and is compressed by the Synthesis Gas Compressor (C-2001) from approximately 3200 kPa to the required pressure of methanol synthesis loop which is approximately 7600 kPa, entering the methanol synthesis system. The compressed synthesis gas is mixed with preheated recycle gas and then routed to the Methanol Reactor(R-2002). The reactor outlet stream needs to be cooled from reactor outlet temperature of approximately 220°C to about 40°C in

order to condense and separate methanol and water from gases. Separation of crude methanol from non-condensed gases performs in Methanol Separator (D-2002). Crude methanol leaves the separator to be purified in distillation unit. The major part of gas is recycled back to the synthesis loop via the Recycle Gas Compressor (C-2002) in order to achieve a high overall conversion. A small amount is withdrawn as purge gas to avoid high accumulation of inerts in the loop.

The simulation of existing methanol synthesis loop is illustrated in Fig. 4 and main streams data are presented in Table I.

TABLE I
 STREAM DATA OF EXISTING SYNTHESIS LOOP

Stream Name	Mass Flow(kg/s)	Temperature (°C)	Pressure (kPa)
2006	247.7	222	7000
2007	247.7	175.1	6940
2008	247.7	126.2	6900
2009	247.7	65	6860
2010	247.7	39.73	6800
2018	88.94	112	12450
2019	88.94	190	12400
2021	171.1	55.36	7650
2021-1	171.1	120	7600
SCWS	794.3	35	4500
SCWR	794.3	43	3500

IV. MODIFIED PROCESS

In the present work, in order to achieve the better use of energy, the integration of a gas turbine with outlet stream of methanol synthesis reactor, which has high temperature and

pressure ($T=222^{\circ}\text{C}$ and $P=7000\text{ kPa}$), is proposed. After finding appropriate placement of gas turbine in methanol synthesis cycle, the optimum turbine outlet pressure should be fixed. Turbine outlet pressure is the most important parameter to attain maximum shaft work, as it affects directly on the shaft power amount of turbine and recycle gas compressor. Sensitivity analysis revealed an optimum range of 3500 to 5000kPa for this parameter. Therefore, in this study the optimum value of turbine outlet pressure is fixed to be 4500 kPa. It is necessary to recompress the recycle synthesis gas after being separated from crude methanol and purge streams. The new integrated system includes power consumption reduction in air cooler (AE-2001) due to temperature reduction caused by gas turbine existence, power generation in gas turbine (GT-2001), addition of new compressor (C-2003) for compression of recycle stream and a new inter cooler which uses sea cooling water as coolant. It should be mentioned that in gas turbine integrated scheme, temperature of turbine outlet stream is not as high as required value to satisfy heating demand of high pressure boiler feed water (HP BFW) whose temperature should rises from 112°C to 190°C . Turbine outlet stream can only heats up this stream up to 164.6°C . Since any changes in temperature of boiler feed water has great influence on steam generation network of the existing plant, so the temperature of this stream should be risen from 164°C to fixed value of 190°C . This is possible through addition of hot utility in gas turbine integrated plant. Process flow diagram of gas turbine integrated system is shown in Fig. 5. All main stream data are presented in Table II.

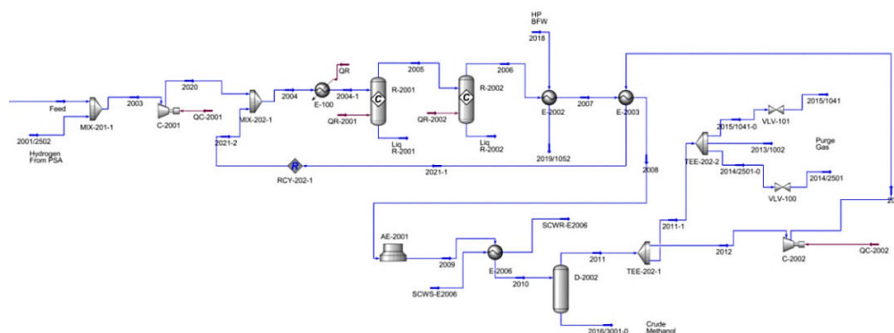

Fig. 4 Process flow diagram of methanol synthesis loop

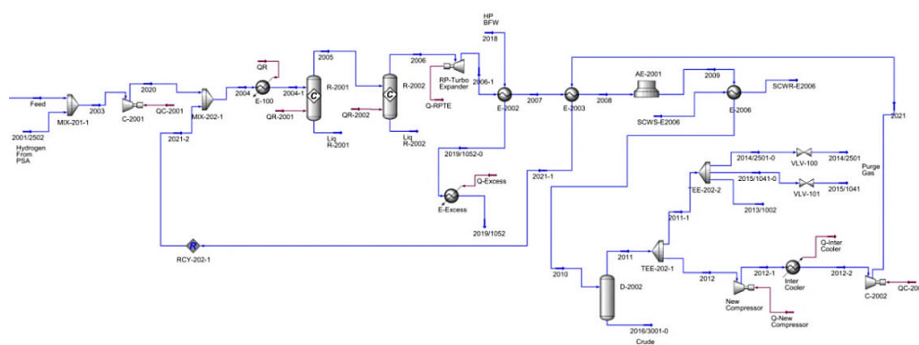

Fig. 5 Process flow diagram of gas turbine integrated system

TABLE II
STREAM DATA OF GAS TURBINE INTEGRATED SYNTHESIS LOOP

Stream Name	Mass Flow(kg/s)	Temperature (°C)	Pressure (kPa)
2006	247.7	222	7000
2006-1	247.7	176.6	4500
2007	247.7	142.3	4440
2008	247.7	108.4	4400
2009	247.7	65	4360
2010	247.7	41.79	4300
2018	88.94	112	12450
2019	88.94	164.6	12400
2021	171.1	67.64	7650
2021-1	171.1	120	7600
2012	171.1	41.77	4290
2012-1	171.1	86.68	6540
2012-2	171.1	51	6540
SCWS	794.3	35	450
SCWR	794.3	43	350

V. RESULTS AND DISCUSSION

Although use of turbine expander on the high temperature/pressure outlet stream of the exothermic reactor in methanol plant leads to addition of energy in forms of hot and cold utilities, it can recover energy in the form of power. In new configuration, 28.4 MW work is generated in gas turbine and part of this produced work, which is approximately 21 MW, is consumed to compress the recycle stream in new compressor. In addition to this power production, power consumption of air cooler is reduced by 0.25 MW. Thus, the amount of 7.6 MW net power is produced. Also, additional hot and cold utilities in the modified configuration are calculated to be 10.9 MW and 17.6 MW, respectively. Investment of new turbine, new compressor, and total capital cost of boiler feed water heater and intercooler in the modified plant are estimated to be MUSD 16.96 [4], [13]. The results are presented in Tables III and IV.

TABLE III
UNIT OPERATION CAPITAL COST

	Cost (MUSD)
Gas Turbine	10.6
Compressor	6.3
Exchanger Area	0.062
Total Investment	16.96

TABLE IV
ENERGY SAVING RESULTS

	Amount (kW)	Cost (MUSD)
Additional Hot Utility	10970	2.5
Additional Cold Utility	17630	0.73
Net Shaft Work	7460	6.6
Air Cooler Power Saving	246	0.22
Total Saving	-	3.6

VI. CONCLUSION

The present work focuses on efficient use of energy in methanol production plant. In existing plant, the outlet stream

of methanol reactor is cooled without any power generation. However, in the modified process, the reactor outlet stream is routed to a gas turbine with the aim of conversion of high temperature/pressure heat to power. Based on economic data, total investment of new equipment including a gas turbine, a compressor, a heater and an inter cooler is about MUSD 16.9. The annual credit of electricity generation is MUSD/yr6.8. Also the annual cost of additional utilities is about MUSD/yr3.2 [14],[15]. Hence, the net energy saving value is calculated to be MUSD/yr3.6. According to these values, payback period is approximately 4.7 years.

ACKNOWLEDGMENT

The authors would like to express their gratitude for financial support from Iran Fuel Conservation Organization (IFCO) throughout this research work.

REFERENCES

- [1] Narvaez, D. Chadwick, L. Kershenbaum, "Small-medium scale polygeneration systems: Methanol and power Production" Applied Energy, 2014. 113: p. 1109–1117.
- [2] M. Soltanieh, K.M. Azar, and M. Saber, "Development of a zero emission integrated system for co-production of electricity and methanol through renewable hydrogen and CO₂ capture" International Journal of Greenhouse Gas Control, 2012. 7(0): p. 145-152.
- [3] A.K. Kralj, "Electricity cogeneration in an exothermic reactor circuit system using an open gas turbine" Fuel, 2014. 118(0): p. 220-226.
- [4] M. Sahafzadeh, A. Ataei, N. Tahouni, M.H. Panjeshahi, "Integration of a gas turbine with an ammonia process for improving energy efficiency" Appl. Therm. Eng. 58 (2013) 594-604.
- [5] H. Axelsson, S. Harvey, A. Asblad, T. Berntsson, "Potential for greenhouse gas reduction in industry through increased heat recovery and/or integration of combined heat and power" Appl. Therm. Eng. 23 (2003) 65–87.
- [6] B. Kalitventzoff, F. Marechal, H. Closon, "Better solutions for process sustainability through better insight in process energy integration" Appl. Therm. Eng. 21 (2001) 1349–1368.
- [7] F.J.J.G Janssen, A.H.M. Verkooijen, P.J. Ploumen, "Synthesis of ethane" European Patent 0753652, assigned to N.V. Kema, The Netherlands, 1997.
- [8] M.A. Agee, L.J. Weick, K.L. Agee, E.L. Trepper, "Synthesis gas production system and method" US Patent 6155039, assigned to Syntroleum Corp (US), 2000.
- [9] J. Perold, I.L. Greeff, K.J. Ptasinski, F.J.J.G Janssen, "Using a turbine expander to recover exothermic reaction heat a case study on a phthalic anhydride process" S. Afr. J. Chem. 13(2001) 1–14.
- [10] I.L. Greeff, J.A. Visser, K.J. Ptasinski, F.J.J.G Janssen, "Utilization of reactor heat in methanol synthesis to reduce compressor duty application of power cycle principles and simulation tools" Appl. Therm. Eng. 22 (2002) 1549–1458.
- [11] I.L. Greeff, J.A. Visser, K.J. Ptasinski, F.J.J.G Janssen, "Integration of a turbine expander with an exothermic reactor loop flow sheet development and application to ammonia production" Energy. 28 (2003) 1495-1509.
- [12] A. K. Kralj, P. Glavic, "Multi-criteria optimization in a methanol process" Appl. Therm. Eng. 29 (2009) 1043–1049.
- [13] H.P. Loh, J. Lyons, I. Charles, W. White, "Process Equipment Cost Estimation" Final report, U.S. Department of Energy, National Energy Technology Laboratory, 2002. DOE/NETL-2002/1169.
- [14] BahadorBakhtiari, Serge Bedard, "Retrofitting heat exchanger networks using a modified network pinch approach" Applied Thermal Engineering, Volume 51, Issues 1–2, March 2013, Pages 973-979.
- [15] Kheen Nam Sun, SharifahRafidah Wan Alwi, Zainuddin Abdul Manan, "Heat exchanger network cost optimization considering multiple utilities and different types of heat exchangers" Computers & Chemical Engineering, Volume 49, 11 February 2013, Pages 194-204.