

Multifunctional Bending and Straightening Machines for Shipbuilding

V. Yu. Shungin, A. V. Popov

Abstract—The paper gives basic information on application of rotation bending for manufacturing ship hull parts from steel plates and on MGPS machines, employed for this purpose.

Keywords—Roller bending, steel plates, shipbuilding, ship repair.

I. INTRODUCTION

At present, one of the main tasks of Russian shipbuilding yards is implementation of new technologies and replacement of main process equipment. In particular, conventional bending technologies with dies are being replaced with resource-saving methods of rotation (roller) bending. Such rolling bending is performed by multiple rolling of a plate in special bending rollers. Studies, conducted in JSC SSTC, allowed developing a theory of rotation bending, methods for calculation of process parameters, requirements to roller presses and bending accessories. This technology allows replacing old and expensive presses with new cheaper roller ones, having less power consumption and bending force. At first, roller presses were implemented in ship repair, however now they are widely employed at major shipbuilding yards. JSC SSTC develops bending technology and carries out design, manufacturing and delivery of roller presses.

II. BENDING TECHNOLOGIES

Plate bending equipment is absolutely necessary for shipbuilding production. Normally, bending is performed by pressing with dies or in rolls.

Plates, subject for bending in one direction, are processed in rolls, and their edges are bended with a press. In other case, such parts are bent with press, equipped with special die, by series of sequential pressing. Two-direction bending is made with presses and special dies. If necessary, dies may be manufactured for bending of a particular parts, however this is very labor-intensive and expensive procedure, and such expenses are not paid back in case of small-series or individual production. Therefore, in normal practice bending is performed with the help of available dies, more or less suitable for the particular operation. In this case, accuracy and quality of bending depend on how the available die fits, and on skills of the bender [1].

V. Yu. Shungin and A. V. Popov are with JSC Shipbuilding and Shiprepair Technology Center (7, Promyshlennaya Str., Saint-Petersburg, 198095, Russia. Phone +7-812-786-26-10; Fax: +7-812-786-04-59; e-mail: inbox@sstc.spb.ru).



Fig. 1 Press "Clearing", 3500 kN (350t) capacity

The other methods are bending with heating, namely hot bending and bending with local heating.

Till now, many yards use hot bending for shaping of hull parts. For this purpose there are special large-sized ovens, where parts are heated to 800-1000°C. After that bending is performed in one pressing with the help of a special die, or manually, by hammering, with the help of various wedges, clamps and beds. Local heating is done with gas torches in particular areas of a plate.

Practice shows, that roller bending can be successfully employed for shaping of hull parts from plates [2]. It is widely used for small-series and individual production, e.g. for bending of parts for automobile bodies, or for bending of thin parts in shipbuilding. By now, roller bending is more and more frequently employed in shipbuilding [3]. Such bending can be performed either with special roller presses or with the help of roller arrangement, mounted on a conventional press.

III. EVALUATION OF ROLLER BENDING USAGE

In a hull shop, plate bending facility is one of the main and most expensive equipment. At Russian yards, plates are bent with presses with capacity from 4 MN (400 t) to 50 MN (500 t), with use of dies. Also, bending rolls are used, with rolls from 2 to 10 m long. Most powerful bending equipment is usually unique, weighing dozens tons and costing several million euros. For presses, a number of universal and special dies are required. Universal dies are used for bending cylindrical, conic and spherical parts. Each die is intended for a certain range of bending radius; therefore several sets of die arrangement are normally required. Due to vast area of deformation and large bending force, such arrangement has

large size and weight, and cost of accessories can make up to 20% of price of a press itself. For complex-shaped parts it is often necessary to manufacture special dies.

Shortcomings of hot bending are requirement of special dies or hard manual work, and necessity of special bed. Accuracy of hot bending does not meet production requirements. Some thermal treatment usually is necessary after bending, also reducing accuracy. As a result, after hot bending some corrective cold bending is required. As for bending with local heating, its productivity is too low and quality strongly depends on skills and experience of bending operator.

In practice, roller bending ensures the required accuracy and productivity for most of bent hull parts, especially for hull endings. Roller arrangement and accessories are several times lighter and cheaper comparing to dies. No special dies are required for this type of bending. As a result, pre-production engineering is much shorter in time and less expensive. The force is applied locally; therefore its value is almost 15 times less, which leads, above all, to energy savings. If bending roller moves on the surface with sufficient velocity, bending productivity will also meet the process requirements.

Roller bending allows stretching the necessary portions of plate, thus no heating is required.

All the above mentioned aspects give substantial economic effect. Installation of roller presses instead of conventional ones allows reducing expenses for acquisition, installation and operation of the equipment. There is no requirement of deep foundations, energy consumption greatly reduces, volume of oil in hydraulic system is much less, and, finally bending arrangement is 10-20 times lighter. At the same time, the process provides required accuracy, quality and productivity of bending.

IV. ROLLER BENDING OF HULL PARTS IN SHIPBUILDING

Roller bending requires only local force application to a small area of a plate, thus ensuring good process accuracy. Deflection of plate under roller during bending, bending force, direction and sequence of rollings, as well as geometry of bending tool surface can be validated and calculated. Finally, bending procedure can be defined in advance and then be given to an operator in the form of digital data, thus reducing time and labor expenses for bending. In addition, the process can be automated [4].

When bending a plate for the future hull part, it is required to obtain certain elastic deformations. Here, direction and scope of deformations depend on shape and size of a plate. Deformations are distinguished to longitudinal and bending deformations. Longitudinal deformations do not change plate thickness, but change themselves from one point on the plate surface to another. Longitudinal deformations are necessary in case if there is a requirement of double curvature of the plate. Bending deformations change linearly through plate thickness and are approximately equal to zero in the middle of the plate.

When doing roller bending, first longitudinal deformations are obtained with cylindrical bending roller. After that bending deformations are made with concave roller.

Required number of rollings can be dozens or hundreds. As per common opinion, very high bending productivity in shipbuilding is not required. However, bending operation in shipbuilding are at the critical stage of construction process, therefore increasing bending productivity and reducing labor intensiveness are very important.

For parts with single curvature roller bending productivity is less than that of universal die. To increase productivity, bending can be divided into stages, e.g. preliminary bending on conventional press and final – on roller one.

For parts with double curvature, productivity of roller bending is much less than of bending with special dies; however such dies usually do not give the exact shape of bended parts. Therefore it is necessary to apply a "post-bending", in the same die with use of some inserts. This is labor-intensive and quite dangerous operations. In most of cases the best solution is combination of techniques, i.e. at the first stage the plate is roughly bent with a suitable die, and final bending is done with roller press. Another way is stretching a plate with roller bending, rough bending with long rolls and final bending with roller press.

In other words, the best solution is to combine techniques instead of opposing them, to achieve the best results.

V. APPLICATION OF MULTIFUNCTIONAL BENDING AND STRAIGHTENING MACHINES IN SHIPBUILDING

The first roller press (plate banding machine LGS) was manufactured in Russia in the middle of XX century, however the theory of roller bending was not yet developed, and evaluated techniques, process calculation methods, parameters of roller press and bending arrangement were not known. As a result, roller bending in shipbuilding was applied only for small plates (3-4 m long and up to 10-12 mm thick). Bending was performed only by most skilled operators and was very low productive. Bending quality and accuracy did not meet the technological requirements.

Studies, conducted in JSC SSTC, allowed developing a theory of rotation bending, techniques and methods of calculations for the same. Roller banding was called "rotation-local deformation", because it can be performed many ways: in rollers, with roller and matrix, in universal small-size die. New machines were designed and manufactured, named "multifunctional bending and straightening machines" (MGPS). These machines are really multifunctional, because they can be used for shaping most of parts of ship hull. Also, roller bending can be used for profile parts (bending by stretching one of legs) [5].

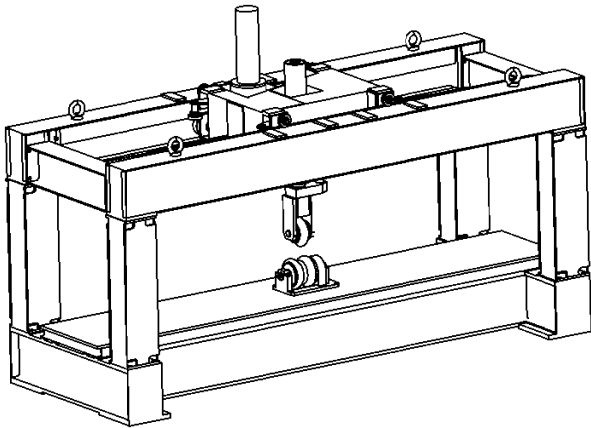

Fig. 2 Machine MGPS-25, capacity 250 kN (25 t)

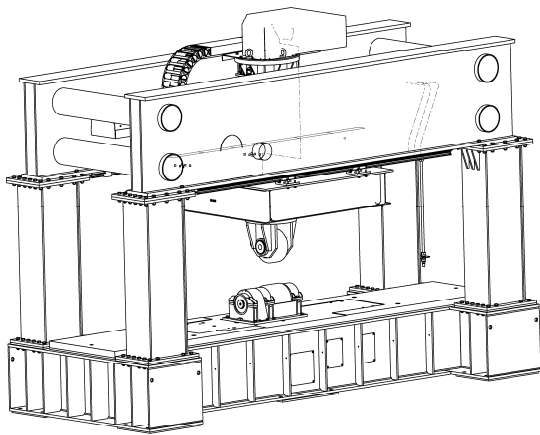

Fig. 3 Machine MGPS-100, capacity 1000 kN (100 t)

By now, JSC SSTC has developed two types of machines: MGPS-25 for plates up to 16-20 mm thick, and MGPS-100 for plates up to 30-40 mm. Size of bent plates are up to 2.5 x 8.0 m..

MGPS-25 with capacity 250 kN (25 t), weight 10 t and power 11 kW have been manufactured since 1995. These machines have been supplied and are now in operation at Russian shipyards and railcar manufacturing plants. Two machines were delivered to foreign customers.

MGPS-25 has important design features, giving it some technological advantages:

- increased size of portal for processing of plates up to 2.5 m thick.
- movable carriage with upper bending roll (or male die), thus allowing application rotary matrix, apart from lower bending roll;
- wide working table, where, one can install any bending arrangement or bend (or straighten) a plate;
- motors and reduction gear are located outside working area of roller press;
- two bending modes: bending by preset shape or with preset force;

- smooth changing of upper roller vertical travel and pressure in hydraulic cylinder allows to strictly follow the preset shape or adjust bending force;
- large pressure gauge on the carriage and digital indicators on control panel showing vertical travel of upper roller and bending force, allow monitoring of bending modes;
- frequency-controlled electric drives for moving carriage with bending roller along the portal and for rotation of lower roller allow to change bending speed smoothly, e.g. reduce it when upper roller approaches edge of the plate;
- control of all bending operations from one panel;
- various bending and technological appliances;
- improved geometry of strengthened surface of fast-replaceable rollers, dies and male-dies;
- supports for plates.

Next step in development of a new generation of plate bending equipment was machine MGPS-100 with capacity 1000 kN (100 t), weight 33 tons and power 45 kW. Both machines MGPS-25 and -100 have similar design, but MGPS-100 is additionally equipped with two gantry cranes, working together with roller press. Control over cranes and press is performed from one control panel.

Moving of cranes, hoists and lifting/lowering of hooks are synchronized with rotation of lower roller. Also, there is an option to control shape of bent plates during bending by individual sections, with the help of two laser scanners (virtual template) [6]. By now two such machines are manufactured.

Detailed theory of bending allows to train bending operators in two weeks. After 3-5 months of practice, such operators will be able to perform operations of all grades, with use of guiding technical documents.

Experience, gained by JSC SSTC in designing, manufacturing and operating machines MGPS-25 and MGPS-100 allows starting designing more powerful equipment, and, in the future, introducing automation to roller bending process.



Fig. 4 Bending plate with MGPS-25 machine



Fig. 5 Bending profile with MGPS-25



Fig. 6 Bending plate with MGPS-100 machine

REFERENCES

- [1] Vainer L.M., Kulikov V.P., Kuklin O.S., Shungin V.Y. Development of technologies for thick plates shaping using consequential local shaping method // Vestnik tehnologii sudostroenija (Shipbuilding Technology Herald), 2010. No. 18
- [2] Ibragimov E.H., Vasiljev A.A., Nesterov V.G., Morozov K.N. Features of implementation of modern shipbuilding and shiprepair technologies on shipyards of India // Morskoy vestnik (Sea Herald), 2007 No. 3 (6)
- [3] Levshakov V.V., Vasiljev A.A., Kuklin O.S., Shungin V.Y. Modern technologies for manufacturing hull structures from light alloys. // Vestnik tehnologii sudostroenija (Shipbuilding Technology Herald), 2013. No. 21
- [4] Smirnov O.A., Shungin V.Y., Bending and straightening machines for plates bending with use of low pressure stampless local-rotary shaping procedure// Vestnik tehnologii sudostroenija (Shipbuilding Technology Herald), 2008. No. 16
- [5] Popov V.I., Kuklin O.S. Modern technologies and equipment for manufacturing of hull profiled parts from new nitrogen containing steels and light alloys // Morskoy vestnik (Sea Herald), 2007 No. 3 (6)
- [6] Kornev A.V., Sinitsky V.A., Shungin V.Y. Production experience of automated check of geometrical parameters of hull structures and parts with use of laser tachometer // Vestnik tehnologii sudostroenija (Shipbuilding Technology Herald), 2012. No. 20

V.Yu. Shungin. Leading research assistant, JSC SSTC, M.Sc. Graduates State Marine Technical University in 1996. Research specialization – development of bending technology for hull structures.

A.V. Popov. Chief designer, Design Bureau for Shipbuilding Equipment, M.Sc. Graduated from Baltic State Technical University in 1995. Research specialization – bending and painting equipment for shipbuilding.