

Supergrid Modeling and Operation and Control of Multi Terminal DC Grids for the Deployment of a Meshed HVDC Grid in South Asia

Farhan Beg, Raymond Moberly

Abstract—The Indian subcontinent is facing a massive challenge with regards to energy security in its member countries; to provide reliable electricity to facilitate development across various sectors of the economy and consequently achieve the developmental targets. The instability of the current precarious situation is observable in the frequent system failures and blackouts.

The deployment of interconnected electricity 'Supergrid' designed to carry huge quanta of power across the Indian sub-continent is proposed in this paper. Not only enabling energy security in the subcontinent it will also provide a platform for Renewable Energy Sources (RES) integration. This paper assesses the need and conditions for a Supergrid deployment and consequently proposes a meshed topology based on Voltage Source High Voltage Direct Current (VSC- HVDC) converters for the Supergrid modeling. Various control schemes for the control of voltage and power are utilized for the regulation of the network parameters. A 3 terminal Multi Terminal Direct Current (MTDC) network is used for the simulations.

Keywords—Super grid, Wind and Solar energy, High Voltage Direct Current, Electricity management, Load Flow Analysis.

I. INTRODUCTION

CLIMATE change activism as well as a limited access of primary conventional fuels is setting the platform for a subtle shift to a CO₂ neutral, multi-layered energy system. In this transformation renewable energies will play a leading role followed by the formation of energy corridors for transport of the clean energy. A great potential of renewable energy has been estimated in the Indian subcontinent [1]. Large amounts of wind and solar energy have been estimated in some parts of the subcontinent while as others have a high potential for biomass and hydro. Procurement and hence introduction of such a vast potential involves the deployment of a superimposed grid network that spans across international boundaries into various countries of the Indian subcontinent. Such an integration of the huge quantum of energy into a grid that transcends borders is one of the biggest challenges of this

century [2], [3]. Moreover what sets this challenge apart involves bringing the measures of technical quality and power supply reliability as well as the maintenance of stability in the same frame with economic and ecological aspects.

A huge energy potential has been estimated in areas not in immediate proximity to future production or load centers and hence need high voltage corridors to connect them to the already existing power focal points [4]. Transport of electrical energy will require the unbundling of electricity generation and distribution from the politically motivated factors related to electricity regulation. The established power corridors can provide a reliable supply based on the transference of controlled conventional power over large distances in times of high demand and consequent low supply from local focal points which are actually the local energy centers. Thus there is a strong need to augment the already present high voltage power corridors with new ones. Advances in the technical, political and regulatory underpinnings involving power intensive energy transport is necessary to see a large interconnected South Asian energy market endowed with large amounts of variable as well as conventional electricity providing reliable, sustainable and a superior quality of electricity across the Indian subcontinent. Hence on a local scale significant structural modifications need to be carried out. Transmission of a huge quantum of power requires the development of high voltage energy corridors that have the capability to transfer energy reliably and efficiently. These energy corridors will consist of an interconnected network of Extra High Voltage (EHV) transmission lines. The planning of these corridors requires the consideration of economics and transmission efficiency.

A Supergrid is a massive transmission network augmented to provide a standard for efficient and reliable transmission of electric power over large areas involving multi-area interconnections and tie-lines while providing the platform for renewable energy integration. The Supergrid is modeled as a meshed HVDC grid structure/topology providing the required redundancy to adhere to the IEEE definition of a reliable and an effective grid in a way that leads to a conception by design of a highly dynamic and robust electricity environment [5].

Consequently the presence of a super grid in the Indian Subcontinent will provide the basic platform to connect the five countries to a sustainable and a massive energy resource. It will facilitate an international energy market in which electricity will be deregulated and treated as a commodity that is supplied without qualitative differentiation across a market.

Farhan Beg is a researcher with the Global Energy Network Institute based in San Diego USA and is a certified power engineer from the National Institute of Technology, Srinagar India. Affiliation: Global Energy Network Institute, San Diego California, (Contact Number: +919858943309; e-mail: farhan.beg@geni.org).

Dr. Raymond Moberly is an adjunct researcher and lecturer in Mathematics at San Diego State University. He holds a bachelor's degree in engineering from Caltech, masters in applied mathematics from San Diego State University, and a doctorate in computational science from the Claremont Graduate University. (Contact Number: +16192291492; e-mail: raymond.moberly@geni.org).

The super grid can also lead to an interconnection of national energy markets and that completely transforms the way electricity is produced, transmitted and consumed in the subcontinent.

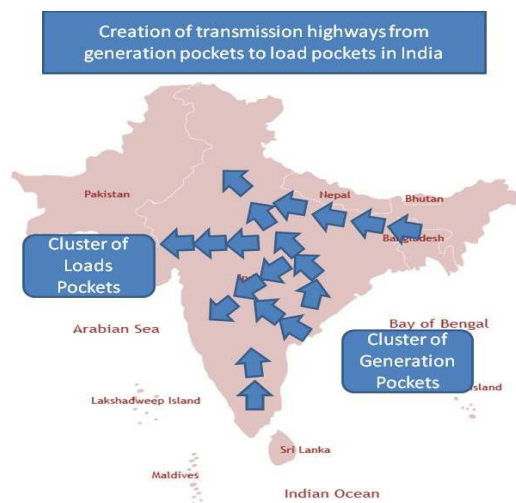

Fig. 1 Creation of transmission highways from generation pockets to load pockets in India

II. METHODOLOGY OF THE SUPERGRID DEPLOYMENT

The Supergrid can introduce a stable and a reliable power infrastructure in the Indian subcontinent with the capability to bring energy and financial stability in the area. By connecting supply chains to load centers using enhanced control, the super grid offers a comprehensive solution to the issue of energy instability. Moreover the geographical spread of such an infra-structure introduces a huge variety in the energy portfolio available increasing the security of supply. Super grid deployment involves certain key issues that pose a serious hurdle. While as the technical portion can be figured out by utilizing the idea of a meshed smart grid system, the actual deployment in the subcontinent brings with it some other potential risks that need to be studied separately. Modeling of the super grid has been done based on a comparative analysis in which the most feasible technology available has been shown to provide the links and nodes of the super grid. Moreover potential generation sites as well as potential load centers have been kept in mind while applying the concepts of power losses due to transmission and distribution. This analysis comes under the heading of “modeling of the super grid in the sub continent” and hence conceptualizes the transformation of connecting different nodes via high voltage energy links. The key risks before the deployment and consequent development of a super grid are non technical.

III. MODELING OF THE SUPERGRID

When the Supergrid provides an electricity highway for the flow of electric power between nations it will have to efficiently control the exchange of seasonally varying production, consumption and storage capacities. The following subsections discuss the different considerations for

the structure and the type of technology for the energy corridors.

A. State of Technology

Among the current technologies we consider the following four choices for the construction of the overlay grids that can provide the energy transfer corridors [6], [7]:

1. Three- Phase AC technology 50 Hz (AC grids) with voltages >400 KV (750 KV, 1000 KV)
2. Three- Phase AC technology with reduced frequency (AC grids 16 2/3 HZ) with voltages > 400 KV
3. HVDC with network controlled converters (LCC-HVDC, HVDC classic)
4. HVDC with self commutated converters (VSC-HVDC)

Constant research into the development of three-phase AC technology as a result of an increasing requirement on transmitted power over longer distances has led to the introduction of increased voltage levels [8]. Overhead lines, cables as well as Gas Insulated Lines (GIL) are now available as AC transport medium. Overhead lines provide the standard solution due to lower investment costs for high voltage transmission. Some of the latest developments in overhead line technology include line conductor monitoring, high temperature conductors as well as considerable improvement of tower designs in respect with space and field strength distribution.

Three-Phase with reduced frequency of 16 2/3Hz is already used in certain countries as traction power supply. Larger distances than in standard frequency AC systems can be bridged using such a power system. The power transferred from one node to another is inversely proportional to the frequency of supply. Hence reduction in the frequency of supply leads to more amount of power flow. There is a strong criticism about these technologies as equipments like transformers for reduced frequency AC systems have larger dimensions than the standard frequency AC. A considerable converter expense also needs to be planned which is larger than with DC grids.

As an emerging technology, HVDC systems technology provides a highly efficient and a flexible transmission system. The HVDC transmission system will provide the required flexibility to integrate renewable energy sources such as wind and solar energy in the grid. It will support the increase in the number of the connections and power flow between energy. The HVDC system provides the platform to interconnect two AC power systems that are not synchronized as well as transfer of electric power between two distant nodal points through overhead transmission or submarine cables. HVDC systems are more cost effective than AC systems because the costs of transformer stations are not considerable [9]. However the critical length is reached between 800 and 1200 kilometers. Even though up to this length the AC overhead lines are more economical today, HVDC has definite advantages with longer cable connections. For the Supergrid deployment the HVDC transmission system provides superior working conditions, a better power flow control and a definite platform for future additions on the supply side which can be

from other conventional generation plants or renewable energy parks.

The converter stations form the backbone of an efficient HVDC transmission system. The two kinds of converter technologies currently used are: Line Commutated Current Source Converters (CSC's) and Self Commutated Voltage Source Converters (VSC's).

HVDC systems based on the principle of conventional CSC's require a substantially large generation source with a very high level of short circuit ratio in order to operate satisfactorily. In other words there is a need for the transference of reactive power from the AC system at the point of contacts to the converter so accomplish the conversion process which amounts to nearly about 50 percent of the total active power through the converter. Moreover based on the CSC technology principle, power flow direction can be reversed only by reversing the Direct Current DC voltage polarity. This characteristic needs a highly complicated switching technique in case the CSC system is used for building a Multi Terminal Direct Current System (MTDC).

On the contrary, VSCs utilizing the Insulated Gate bipolar transistor (IGBT) valves as well as Pulse Width Modulation (PWM) techniques can lead to the production of a near sinusoidal AC voltage which is fully controllable with respect to magnitude and phase of the AC wave. Unlike the CSC systems, VSCs have no reactive power demand and can also exchange the reactive power with the AC grid.

VSCs can rapidly control the active power exchange by controlling the phase angle of the produced voltage as well as control the reactive power at each terminal by controlling the magnitude of VSC voltage independent of the Direct current power transmission. Due to this property VSCs can be installed anywhere in the AC grid irrespective of the short circuit current capacity. Moreover to change the direction of the power flow in its DC link, VSC does not need to reverse the voltage polarity. This power reversal is observed by changing the direction of the current. Many attempts have already been made to conceptualize the formation of the meshed grids using classic HVDC or CSC technology. However due to the high amount of complexity involved the projects were thereby limited to a maximum of 3 nodes [10]. On the other hand the VSC-HVDC provides the most suitable conditions for a multi terminal system which is the basis for the modeling of a super grid because the number of nodes and the kind of grid topology utilized does not have any limit in the case of VSC-HVDC.

B. VSC-HVDC Functional Principle

The working of a VSC converter is based on the synchronous functioning of a 6-pulse bridge circuit of IGBT's (power transistors) controlled by a clocked control signal generating pulses in the range of KHZ frequencies. Provision has to be provided for the serial switching of the multiple semi conductors in order to account for the limited reverse voltage capacity of the power electronic elements. Intelligent control techniques can introduce a very high flexibility in the output

voltage control in order to obtain the desired active and reactive power. AC voltage is formed by the use of PWM modulation in case of PWM VSC converters and DC voltage is smoothed by the use of DC capacitors. There is a higher precision of synchronism if a higher clock frequency is used. PWM technology has been in use for nearly a decade now and two and three level VSC converters with better ratings and efficiency are now available.

Constant research into upgrading the ratings and the frequency of VSC converters has led to the use of a modular construction based on the use of multi-level technology [11]. Sub-modules consisting of half bridges having two valves and a module capacitor are at the heart of sub module architectures. Partial voltages of the sub modules combine to the complete voltage of the branches and thereby branches act as controllable voltage sources.

AC voltages are generated by a cumulative process consisting of step functions with hundreds of voltage steps. This directly affects the harmonic components in the voltage sinusoids which are directly reduced and thus improving the overall total harmonic distortion (THD) of the voltage wave. In HVDC technology based on VSC converters reversal of power depends on the reversal of current unlike the LCC HVDC in which reversal of power depends on the reversal of voltage. Polarity of DC voltage in VSC converter technology always remains the same and makes the use of XLPE- DC cables which provide higher power transmission capabilities possible [12].

C. Application of VSC-HVDC Multi Terminal DC Systems

Multi terminal Direct Current systems (MTDC) hadn't been deployed in practical power systems until 1987 when the first MTDC system was introduced by installing a third terminal in Corsica to the already existing link between Sardinia and Italy [13].

Another landmark achievement was the completion of the first large MTDC system by ABB in 1992 which again was a three terminal HVDC system. While as earlier the MTDC systems used were based on the LCC converters, because of huge advances in the field of VSC converters and their subsequent advantages, the shift is gradual towards using the VSC converters for MTDC system designing. In India itself POWERGRID corporation of India (PGCIL) is installing +/- 800 kV, 6000 MW HVDC multi-terminal system of approx length of 1728 km from North Eastern Region to Agra which will consist of one rectifier station in Biswanath Chariali (in North Eastern Region), second one in Alipurduar (in Eastern Region) and Inverter station at Agra (in Northern Region). This is the first multi terminal system in India consisting of VSC converters

For the deployment of MTDC system two types of configurations are possible; the parallel connection and the series connection. The parallel connection allows the DC terminals to operate around a single rated voltage V_{DC} , while as the series connection involves a single converter that controls the current around a common current rating and the rest of the converters control the power. The series connection

is more suited for CSC MTDC systems as the CSCs on the DC side provide the same functions of a voltage source and thus can be introduced in series connections without any subsequent need for special switching control. The most significant drawback of this configuration in the HVDC applications is its inability to control the losses and the use of complicated insulation. More importantly if due to certain circumstances one of the DC lines is disconnected which may be due to fault conditions; the power flow in the entire DC grid is affected. Hence only parallel configuration is recommended by power engineers to be used in the MTDC systems [14]. However, if CSCs are used for the parallel connection of an MTDC system, a complicated and special switching arrangement has to be introduced to overcome the precise voltage balancing between the converters which arise because of the voltage source nature of the CSCs. This cumulates into a more serious technical issue if the converter stations are far away, which is highly probable in case of a super grid MTDC system, since an inherent need of fast communication channels is needed. However the presence of Smart Grids with fast and reliable communication highways in each of the participating country can to a large extent mitigate this technical problem. Thus formation of more than 5 terminal MTDC system based on CSC converter stations is highly discouraged.

The DC super grid is a direct consequence of the possibility of such connections which can not only connect many unsynchronized grids but also provide a definite medium to integrate the renewable energy from various distributed resources around the subcontinent. Investigative research has to be conducted though to observe the effect of the MTDC systems on a large scale power system since such proposition is a relatively newer one. The Super Grid for the Indian sub continent has to be dynamically connected with a very high flexibility to address the disparate requirements of the countries taking part in such a project. Not only should the super grid provide a stable power flow depending upon the demand and supply difference at different times of the year it should also be able to absorb the intermittent and highly variable renewable power from energy sources that are scattered all over the sub continent. The renewable energy sources have an intermittent nature and can prove to be hazardous for the normal functioning of a large interconnected grid because of the fluctuations endangering the stability of the system. The DC super grid based on the VSC converter systems can allow non conventional energy from different renewable energy sources feed electric power into the common DC super grid thereby providing all the participant countries a steady access to a reliable and stable source of electricity generation.

D. VSC HVDC Station Modeling

The need to understand the underlying structure of the VSC station model arises because of the presence of several VSC stations in the VSC based MTDC systems. Fig. 2 shows the elements constituting a VSC station. The model consists of AC buses, series reactance, AC filters, coupling transformers

and converter blocks on the AC side, and the DC bus, the DC filter and the DC line on the DC side. A single line represents the DC side of the model.

The point of common connection acts as a medium from where the VSC station is connected to the AC grid. The PCC is connected to the AC side of the VSC through a converter transformer, shunt filter and a phase reactor while as on the other side the DC bus, at which a shunt DC capacitor is connected to the ground, is connected to the DC line on one side and the VSC on the other side.

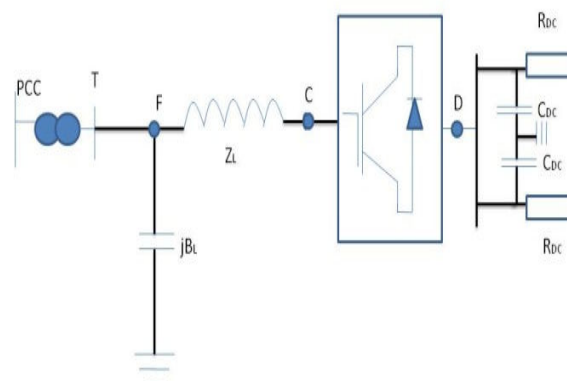

Fig. 2 Modeling of the VSC HVDC stations

IV. POWER FLOW ANALYSIS

A meshed grid topology is assumed for the subsequent discussion on the power flow analysis. Different methods and calculation algorithms that have been proposed for the power flow or load flow analysis of three-phase AC systems are have been refined. The power flow analysis of DC meshed grid depicts a much simplified and exceptional case of the AC power flow analysis. In case of DC grids, for stationary conditions the reactive power and the reactive network devices are nonexistent because of the inherent zero frequency operation of the DC and hence the voltage can be influenced by the active power flow. Quality of power supply is thus a function of voltage and not frequency and thereby only voltage active power control is observed as a control system for DC grids.

The most common practical analysis methods for power flow consist of the Newton Raphson method and the method of joints. The method of joints is based on the principle of current balance and is solved iteratively using the Gauss-Seidel method to obtain the required parameters. The Newton Raphson method uses the power balance techniques of the nodes. Mathematical calculation with a relatively less complexity is observed when the power flow methods were applied to the DC systems than in the three-phase systems because of the crossing over of the complex calculations in the real domain. Consequently the admittance matrix [Y] of the grid converts to the conductance matrix [G]. However the normal step by step process consisting of the creation of the system of equations followed by the analysis of network and the direction arrows depicting the direction of flow of power is determined.

For the calculation of the conductance matrix, Kirchhoff's Voltage law is applied at various nodes, i.e. various node equations are formed and the product of conductance and voltage difference replaces the branch currents. Equations (1) to (8) represent the Kirchhoff's current law at various nodes of the Supergrid which are technically referred to as "supernodes" i.e., nodes of the Supergrid. i_x is the current flowing into a node x , i_{xy} refers to the current flowing from node x to node y , U_x represents the voltage maintained at a particular node x , g_{xy} refers to the conductance of a particular edge of the graph and is a function of distance.

$$i_1 = i_{21} + i_{41} = (U_2 - U_1)/g_{12} + (U_4 - U_1)/g_{14} \quad (1)$$

$$i_2 = i_{12} + i_{32} = (U_1 - U_2)/g_{12} + (U_3 - U_2)/g_{23} \quad (2)$$

$$i_3 = i_{23} + i_{43} + i_{73} = (U_2 - U_3)/g_{23} + (U_4 - U_3)/g_{34} + (U_7 - U_3)/g_{37} \quad (3)$$

$$i_4 = i_{14} + i_{34} + i_{54} = (U_1 - U_4)/g_{14} + (U_3 - U_4)/g_{34} + (U_5 - U_4)/g_{45} \quad (4)$$

$$i_5 = i_{45} + i_{65} = (U_4 - U_5)/g_{45} + (U_6 - U_5)/g_{56} \quad (5)$$

$$i_6 = i_{56} = (U_5 - U_6)/g_{56} \quad (6)$$

$$i_7 = i_{37} + i_{87} = (U_3 - U_7)/g_{37} + (U_8 - U_7)/g_{78} \quad (7)$$

$$i_8 = i_{78} = (U_7 - U_8)/g_{78} \quad (8)$$

The conductance matrix is arranged after the formation of the network equations and replacing the branch currents by the product of conductance and the node voltage difference. In the complete analysis efforts have always been made to replace the current by its equivalent quantities (product of conductance and voltage) depending on the network state.

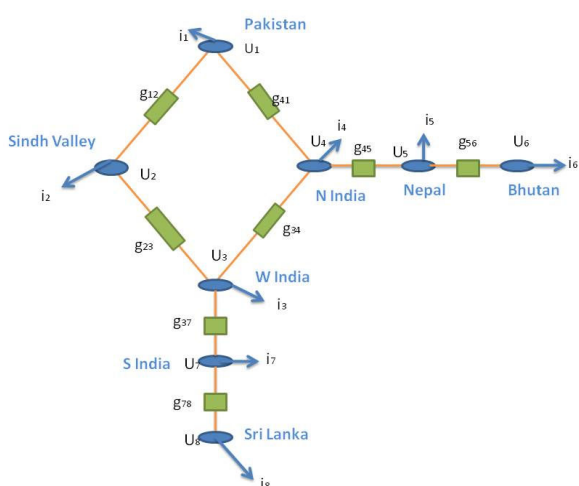

Fig. 3 Analysis and Definition of quantities and arrows in the network

The Gauss Seidel method is the most common iterative method that is used to solve the system of linear equation as it involves the least complexity. Another possibility consists of using the Jacobian method based on the node equations. For solving the equations of the grid based on various bus voltages which are chosen based on the known and unknown values there is a strong need to choose a slack bus which acts as a reference bus and is often the bus consisting of the largest generation capacity. The system of equations is thus modified with the provided slack voltage U_{sl} .

$$[U]_{xy} = [G]_{xy}^{-1} \{ [I]_{xy} - [G_x]_v - [U]_x - U_{sl} [G]_r \} \quad (9)$$

Separating the nodal conductance $[G]_x$ and voltages $[U]_x$ and obtaining the voltage matrix $[U]_{xy}$

Using the iterative solution in every step, node currents are first determined using the node power and then the new state vector is defined which is calculated for the node voltage. The power flow, slack power and the power loss can be determined after converging the voltages or node power with the abort criterion after the required convergency is obtained which in most cases is reached after a maximum of ten steps. It is of course an inherent characteristic of applying power flow analysis to DC systems that the PV buses that are analogous to the three-phase system don't exist in the DC systems. This is attributed to the fact that only power or voltage is possible on each node as only a single degree of freedom exists.

The modification of the Newton Raphson method for application to the DC grids is also possible. This process involves very high complexity and thus this method can be done with at most 4 steps to obtain the same accuracy. Newtonian directional null method lies at the heart of the Newton Raphson method. Using the Taylor series expansion the node power balance is linearized and thereby resolved in each iteration step which leads to the formation of a Jacobian matrix $[J]$.

Linearized equation:

$$\begin{bmatrix} [\Delta P] \\ [\Delta Q] \end{bmatrix} = \begin{bmatrix} H & N \\ M & L \end{bmatrix} * \begin{bmatrix} [\Delta \theta] \\ [\Delta U] \end{bmatrix} = [J] * \begin{bmatrix} [\Delta \theta] \\ [\Delta U] \end{bmatrix} \quad (10)$$

and since in DC systems $\Delta Q = 0$ and $\Delta \theta = 0$;

$$[\Delta P] = [J] * [\Delta U]$$

and the simplified Jacobian matrix is,

$$[J] = \begin{bmatrix} \partial P1/\partial U1 & \partial P1/\partial U2 & \partial P1/\partial U3 & \dots & \partial P1/\partial Un \\ \partial P2/\partial U1 & \partial P2/\partial U2 & \partial P2/\partial U3 & \dots & \partial P2/\partial Un \\ \partial P3/\partial U1 & \partial P3/\partial U2 & \partial P3/\partial U3 & \dots & \partial P3/\partial Un \\ \partial P4/\partial U1 & \partial P4/\partial U2 & \partial P4/\partial U3 & \dots & \partial P4/\partial Un \\ \dots & \dots & \dots & \ddots & \dots \\ \partial Pn/\partial U1 & \partial Pn/\partial U2 & \partial Pn/\partial U3 & \dots & \partial Pn/\partial Un \end{bmatrix} \quad (11)$$

Accordingly,

$$[\Delta U] = [J]^{-1} * [\Delta P]$$

The state vector of voltages are corrected iteratively until the required convergence is achieved which occurs after a maximum of 5 iteration loops.



Fig. 4 Draft of DC multi terminal grid for the Indian subcontinent

V. DESIGN AND CONTROL OF MTDC SYSTEMS

As already concocted and elucidated, there are certain very important reasons for using HVDC for the transfer of power for long distances. The power transfer in the Indian subcontinent takes place under sea between India and Sri Lanka; from wind farms in the Sindh Valley as well as other potential renewable energy centers to mainland. A grid interconnection of asynchronous grids is required for the interconnections. All these capabilities are provided by systems based on HVDC converter stations].

A voltage source converter has been used for the conversion of electrical energy from AC to DC and vice versa. In the case of AC to DC conversion it is called as a rectifier while as for the other type it is called an Inverter.

For this project which may consist of many terminals depending on the participating stations, a three terminal MTDC has been simulated. Two terminals are for the onshore plants with grid interconnections while as one is for the wind farm which has been assumed in the Sindh Valley in Southern Pakistan.

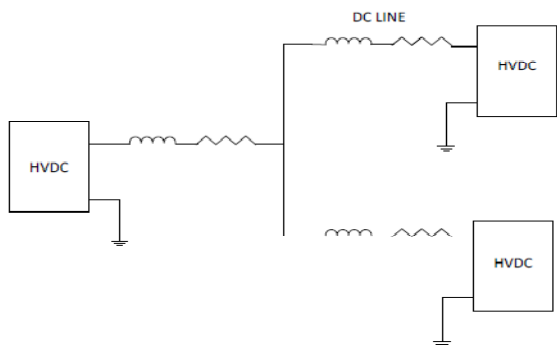

Fig. 5 A 3 Terminal MTDC systems

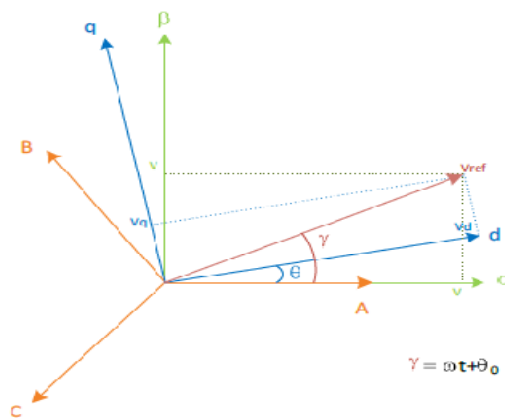

Fig. 6 3-phase Voltage transformations

In this model a bi-polar HVDC system is used which is represented by a line and a ground. The VSC used is a three phase two level converter. For the gate pulse of the IGBT's a sinusoidal PWM scheme is used which is obtained by comparison of the sinusoidal reference by the triangular wave. Fig. 7 shows the generation of the gate pulses. The gate pulse is different depending on the phase shift of the sinusoidal wave. The output current of the converter as shown in Fig. 7 is obtained by using different gate pulses. Since the objective of this research is not VSC, hence the circuit is simplified by replacing the VSC and the PWM scheme by the three current sources as obtained in Fig. 7.

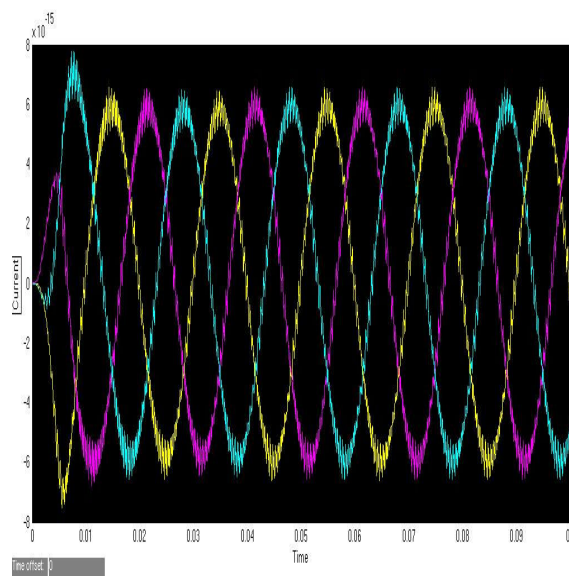

Fig. 7 Output Currents of the VSC

A transformer which adapts the signal of the converter to the grid and also provides galvanic isolation is considered ideal and is replaced by an inductance in series with a resistance.

Various control strategies have been employed in order to obtain optimal output with regards to a reference input as well as to preserve system integrity and restore the normal

operation in the presence of disturbances; external as well as internal.

A. Vector Control

Vector control transforms the currents and voltages into the d-q reference frame which is synchronized by the PLL [15]. Fig. 6 represents the three phase voltage transformations.

The transformation can be done by the Clarke's method which transforms the abc frame into $\alpha\beta$ and then $\alpha\beta$ into d-q. However this transformation can be done directly by the Park's transformation.

1. Phase Locked Loop

Frequency is measured by the PLL, obtaining the angular frequency which will be used in the abc to dq and dq to abc transformation as a reference. The PLL synchronizes the output voltage of the converter to the grid. Fig. 8 shows the PLL scheme.

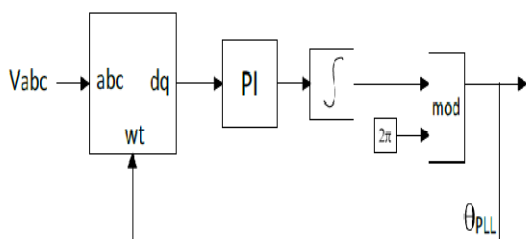

Fig. 8 Phase Lock Loop Scheme

B. Voltage Control

As shown in Fig. 9 the error of voltage is calculated by $V_{DC}^* - V_{DC}$ that is the difference of the voltage reference and the voltage of the DC side, measured in the DC capacitor. The error is passed through a PI controller obtaining id^* the reference of the d-axis current [16]. 'id' and 'vd' are the d-axis current and voltage respectively of the AC side and 'wL' is the transformer reactance.

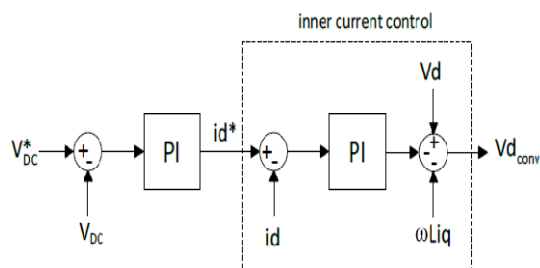

Fig. 9 Voltage Control Scheme

C. Power Control

Similar to the voltage control, the error in power is obtained as the difference of the reference power and the active power of the system. Active power is calculated as:

$$P = \frac{3}{2} V_d * I_d \quad (12)$$

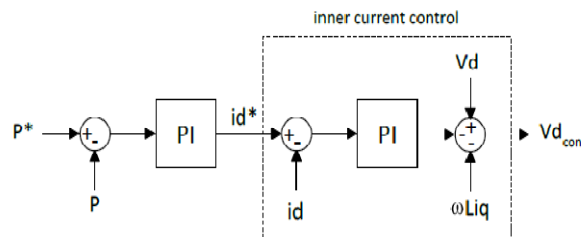

Fig. 10 Power Control

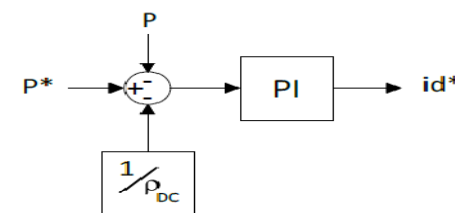

Fig. 11 Droop Control

Once the power and voltage controllers worked, they were replaced by a more robust droop control which regulates both voltage and power. It is not desirable that one terminal regulate the voltage and the other regulates power. The droop control provides a dynamic response for both power and voltage variation. The scheme is represented in Fig. 11. The regulator gain is $\frac{1}{\rho_{dc}}$ and is calculated by

$$V_{dc} = V_{DCref} + \rho_{DC}(P - P_{ref}) \quad (13)$$

$$\rho_{DC} = \frac{V_{DC} - V_{DCref}}{P - P_{ref}} \quad (14)$$

VI. SIMULATION AND RESULTS

The MTDC model designed before is tested in this section. First simulations were obtained for the power and voltage controllers and later for the droop control which was installed in each of the terminals to control both the voltage and power at each terminal.

As the wind is not constant, the variation is simulated by the introduction of a pulse generator which changes its amplitude by .2 every 5 sec. Moreover to simulate the MTDC systems voltage and power references need to be obtained. The voltage reference is 640 KV and the power reference is 400 MW. Depending on the station the power reference will change having a value of .8, .5 or .1.

To verify the results, two study cases are simulated; the three terminal MTDC with voltage and power controller and the three terminal MTDC with droop control.

The three terminals consist of: HVDC 1 and HVDC 2 which are the onshore stations and HVDC 3 which is the offshore station where the wind is varying. HVDC 3 has some DC line impedance, HVDC 1 has double of this impedance and HVDC 2 has triple. Moreover HVDC 3 has 0.8 pu power

reference, HVDC 2 has 0.5 pu and HVDC 1 640KV voltage difference.

As in Fig. 12 HVDC1 voltage reacts to the change in power, but after some seconds the system achieves the reference voltage it had before proving that the voltage regulator is working properly. On the other hand the voltage of HVDC 2 changes since there is an absence of a voltage controller while as the reference power is maintained at HVDC 2. This confirms the successful operation of the active power control. HVDC 1 has no power control, its value is changed when the wind changes.

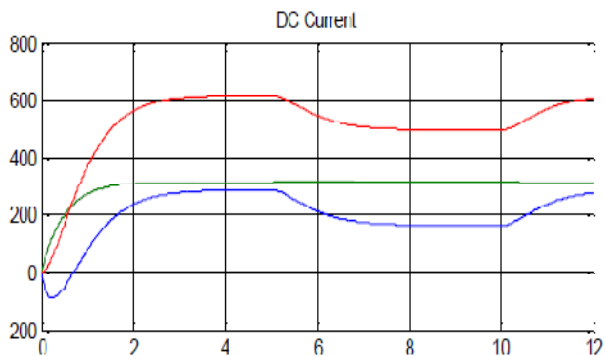

Fig. 12 (a) 3 MTDC with Voltage and Power Control DC Current

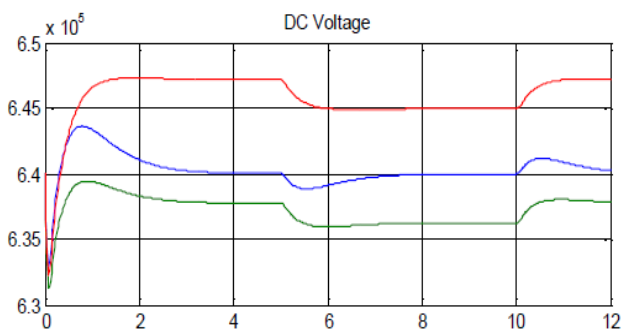

Fig. 12 (b) 3 MTDC with Voltage and Power Control DC Voltage

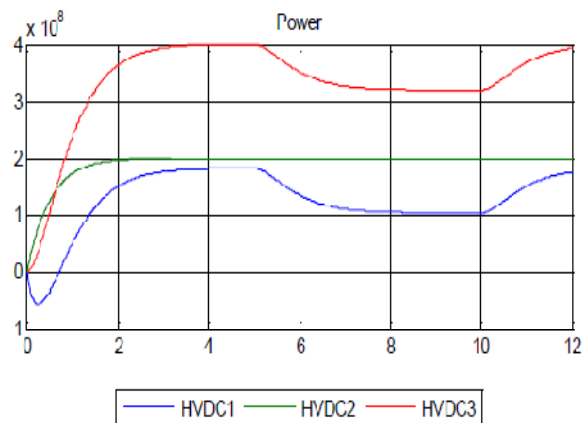

Fig. 12 (c) 3 MTDC with Voltage and Power Control Power

If the DC line is made longer the results are similar to the earlier simulation. The voltage decreases by 5KV and is

compensated with power. The system suffers more losses but HVDC 1 maintains its voltage reference value and HVDC 2 its power reference. If the reference values change, voltage reference in HVDC 1 was increase to 840 KV while power reference in HVDC 2 changed to .8 pu.

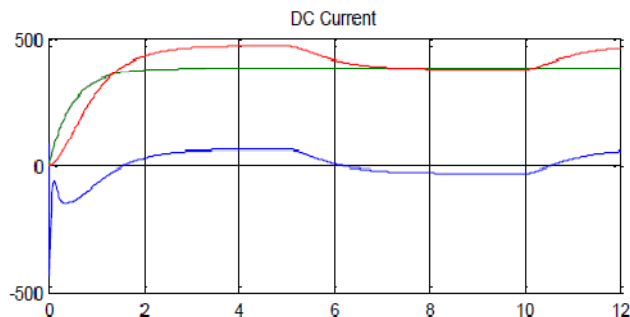

Fig. 13 (a) 3 Terminal MTDC with changed Voltage and Power References

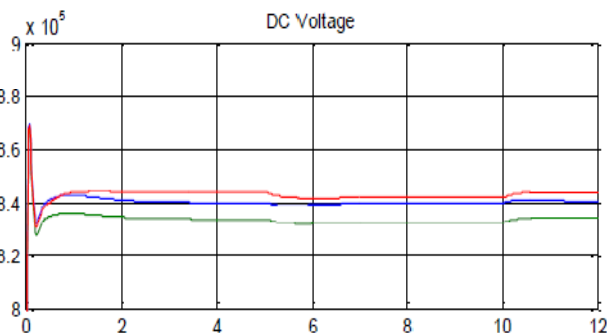

Fig. 13 (b) 3 Terminal MTDC with changed Voltage and Power References

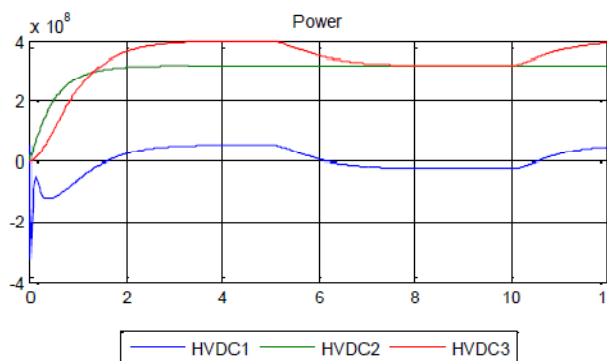

Fig. 13 (c) 3 Terminal MTDC with changed Voltage and Power References

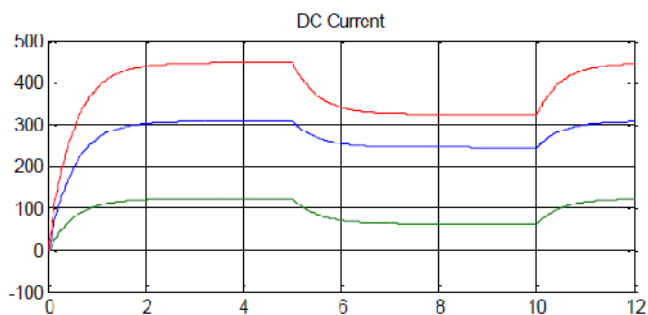

Fig. 14 (a) Voltage and Power with Droop Control

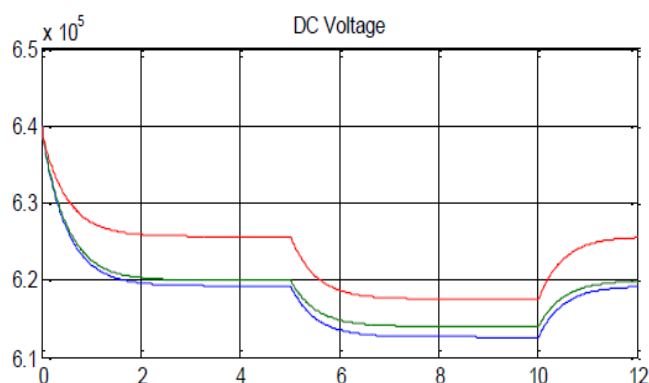

Fig. 14 (b) Voltage and Power with Droop Control

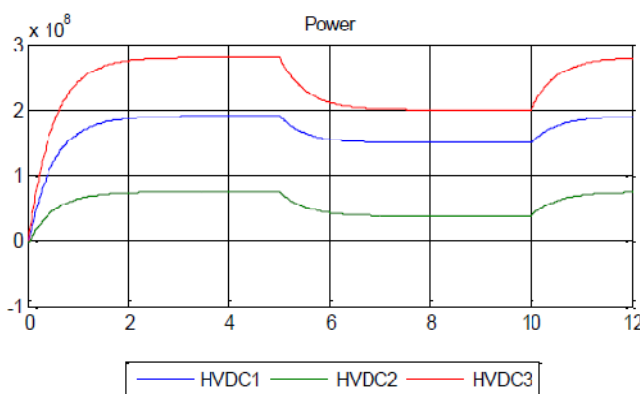

Fig. 14 (c) Voltage and Power with Droop Control

3 Terminal MTDC with droop control was implemented next. The simulations in Fig. 14 show how voltage and power are balanced because of the droop control. HVDC 3 has the same DC line resistance as in the previous case, where as HVDC 1 has 4 times the impedance. The power reference of the offshore station HVDC 3 is .8 pu and for HVDC 2 it is .5 pu and .8 pu for HVDC 1. The voltage reference remains 640 KV for the onshore stations. With the change in the offshore power, the onshore voltage and power suffer a change and result in a variation in the currents. The different stations share the voltage and power changes equally. Power decreases by 80 MW in HVDC 3 which is shared by HVDC 2 and HVDC 1 equally i.e., 40 MW each. In Fig. 14 it is seen that voltage

compensates the variation in power where HVDC 1 has more voltage droop than HVDC2.

VII. CONCLUSION

The power grids of the future need to be highly adaptive with regards to satisfying the needs of the high growth economies of the future as well as dynamic to balance and effectively transfer the huge quanta of power flow. This flexibility in the grid has been proposed to be achieved by interconnecting several grids in order to form a massive interconnected grid that spans across borders. Interconnection of the grid provides a platform for a need based power flow backed by generation in areas of high potential and consequent transfer where it can be used most effectively. This meshed structure is supplemented with a number of decentralized structures that play a part in load coverage as well as allocate excessive energy for power flow.

This paper proposed that a meshed topology for Supergrid deployment is the most feasible because of its dynamic characteristics to efficiently deal with power flow. Simulations proved the essence of control mechanisms to efficiently deal with the various perturbations that the 3 terminal MTDC is subjected to. This practice using the simulated control schemes thereby leads to an interconnection of transmission networks of various participating countries in the subcontinent thus engendering a new concept of grid security and reliability.

ACKNOWLEDGEMENT

The authors would like to thank Mr. Peter Meissen founder Global Energy Network Institute, USA for his valuable insights and suggestions.

REFERENCES

- [1] Beg, Farhan. "Integrating Wind And Solar Energy In India For A Smart Grid Platform." (2013).
- [2] Khaparde, S. A. "Infrastructure for sustainable development using renewable energy technologies in India." *Power Engineering Society General Meeting, 2007. IEEE.* IEEE, 2007.
- [3] Mukhopadhyay, Subrata, et al. "On the progress of renewable energy integration into smart grids in India." *Power and Energy Society General Meeting, 2012 IEEE.* IEEE, 2012.
- [4] Van Hertem, Dirk, and Mehrdad Ghandhari. "Multi-terminal VSC HVDC for the European supergrid: Obstacles." *Renewable and sustainable energy reviews* 14.9 (2010): 3156-3163.
- [5] Bote-Lorenzo, Miguel L., Yannis A. Dimitriadis, and Eduardo Gómez-Sánchez. "Grid characteristics and uses: a grid definition." *Grid Computing.* Springer Berlin Heidelberg, 2004.
- [6] Grainger, John J., and William D. Stevenson. *Power system analysis.* Vol. 621. New York: McGraw-Hill, 1994.
- [7] Teive, R. C. G., E. L. Silva, and L. G. S. Fonseca. "A cooperative expert system for transmission expansion planning of electrical power systems." *Power Systems, IEEE Transactions on* 13.2 (1998): 636-642.
- [8] Belyaev, Andrey N., and Serguei V. Smolovik. "An improvement of AC electrical energy transmission system with series compensation by implementation of Controllable Shunt Reactors." *Power Tech Conference Proceedings, 2003 IEEE Bologna.* Vol. 3. IEEE, 2003.
- [9] Rudervall, Roberto, J. P. Charpentier, and Raghuvveer Sharma. "High voltage direct current (HVDC) transmission systems technology review paper." *Energy week 2000* (2000).
- [10] Meisen, Peter, and Farhan Beg. "Supergrid Modelling And Risk Assessment For The Indian Subcontinent." (2014).

- [11] Wald, Matthew L. "How to build the supergrid." *Scientific American* 303.5 (2010): 56-61.
- [12] Da Silva, Rodrigo, Remus Teodorescu, and Pedro Rodriguez. "Multilink DC transmission system for supergrid future concepts and wind power integration." *Renewable Power Generation (RPG 2011), IET Conference on. IET*, 2011.
- [13] Kumar, Akhil. "An efficient SuperGrid protocol for high availability and load balancing." *Computers, IEEE Transactions on* 49.10 (2000): 1126-1133. 14. Overbye, Thomas J., et al. "National Energy Supergrid Workshop Report." *Crowne Plaza Cabana Palo Alto Hotel, Palo Alto, California* (2002).
- [14] Pinto, R. T., Bauer, P., Rodrigues, S. F., Wiggelinkhuizen, E. J., Pierik, J., & Ferreira, B. (2013). A novel distributed direct-voltage control strategy for grid integration of offshore wind energy systems through MTDC network. *Industrial Electronics, IEEE Transactions on*, 60(6), 2429-2441.
- [15] Haileselassie, T. M., & Uhlen, K. (2012, July). Precise control of power flow in multiterminal VSC-HVDCs using DC voltage droop control. In *Power and Energy Society General Meeting, 2012 IEEE* (pp. 1-9). IEEE.
- [16] Farhan Beg . " *A Novel Fuzzy Logic Based PI Control Strategy for VSC-HVDC Transmission* ", Vol. 3 - Issue 7 (July - 2014), International Journal of Engineering Research & Technology (IJERT) , ISSN: 2278-0181 , www.ijert.org