

# Efficiency of the Strain Based Approach Formulation for Plate Bending Analysis

Djamal Hamadi, Sifeddine Abderrahmani, Toufik Maalem, Oussama Temami

**Abstract**—In recent years many finite elements have been developed for plate bending analysis. The formulated elements are based on the strain based approach. This approach leads to the representation of the displacements by higher order polynomial terms without the need for the introduction of additional internal and unnecessary degrees of freedom. Good convergence can also be obtained when the results are compared with those obtained from the corresponding displacement based elements, having the same total number of degrees of freedom. Furthermore, the plate bending elements are free from any shear locking since they converge to the Kirchhoff solution for thin plates contrarily for the corresponding displacement based elements. In this paper the efficiency of the strain based approach compared to well known displacement formulation is presented. The results obtained by a new formulated plate bending element based on the strain approach and Kirchhoff theory are compared with some others elements. The good convergence of the new formulated element is confirmed.

**Keywords**—Displacement fields, finite elements, plate bending, Kirchhoff theory, strain based approach.

## I. INTRODUCTION

NUMEROUS studies; theoretical and numerical were dedicated to the plate bending. Numerically, the calculation of the thick plate with 3D finite elements has been examined by several authors, Zienkiwicz and Gallagher [1], [2] used these type of elements by maintaining 3D constants, let us quote for example the brick with twenty nodes, B20 and bricks without intermediate nodes following thickness. According to these authors, 3D elements give good results in this last case, but do not approach known solutions for the thin plates [3]. The major inconvenience in the use of these elements of superior order is the high cost; because of large number of numerical integration points necessary for the evaluation of the element stiffness matrix. On the development side, many researchers continue to be preoccupied with the problem of the formulation of new elements and further development of improved algorithms for special phenomena. A new approach of elements was developed at Cardiff University, referred to as the strain based approach. This

Djamal Hamadi is with the Civil Engineering and Hydraulics Department Faculty of Sciences and Technology, Biskra University B.P.145 RP. 07000 – Algeria (fax: 00 2133543198; e-mail: d.hamadi@univ-biskra.dz).

Sifeddine Abderrahmani is with the Civil Engineering Department, Faculty of Sciences and Engineering Sciences, Biskra University, B.P.145.RP. 07000, Algeria (fax: 00 2133543198; e-mail: abderrahmani\_1989@yahoo.com)

Toufik Maalem is with the Civil Engineering Department, University of Batna, RP 05000, Algeria; (e-mail: tmaalem@univ-batna.dz).

Oussama Temami is with the Civil Engineering Department, Faculty of Sciences and Engineering Sciences, Biskra University, B.P.145.RP. 07000, Algeria (fax: 00 2133543198; e-mail: oussamatem@yahoo.com).

approach is based on the calculation of the exact terms representing all the rigid body modes and the other components of the displacement functions which are based on assumed independent strain functions; insofar as it is allowed by the elasticity compatibility equations. The convergence is faster compared to the displacement based elements (in the case where the total number of degrees of freedom would be identical). Many researchers are involved in this new approach. Djoudi involved for non-linear fields and vibrations of cylindrical shells [4], [5], and excellent results have been obtained. A new rectangular element was developed for plan elasticity problems by Belarbi and Maalem [6]. Hamadi *et al.* [7] have formulated a new quadrilateral element with inside node and using static condensation for plane elasticity problems, both elements converge rapidly compared to the displacements quadrilateral elements. For plate bending analysis, Belounar and Guenfoud [8] have developed a new rectangular plate bending element, Hamadi *et al.* [9] have also formulated a new version plate bending finite element. Both elements have six degrees of freedom per node and are based on the strain approach and Mindlin theory formulation, the results obtained are very good compared with corresponding displacement based elements. The main objective of this paper is to present the efficiency of the strain based approach compared to well known displacement formulation, in addition, the results obtained by a new formulated plate bending element based on the strain approach and Kirchhoff theory are given. The good convergence of the new formulated element is confirmed.

## II. PLATE CLASSIFICATION

A plate is an elastic solid which has one dimension is too small compared to the other two dimensions (Fig. 1). Generally it has a plane of symmetry in the middle of the thickness called middle surface [10]. Plates are often classified into two categories, thin or thick depending on the size of the thickness  $h$ . Therefore; it can be classified with the following conditions:

$$\text{For thick plates: } \frac{1}{20} < \frac{h}{L} < \frac{1}{4}$$

$$\text{For thin plates: } \frac{h}{L} < \frac{1}{20}$$

where:  $h$  is the thickness and  $L$  is the small dimension

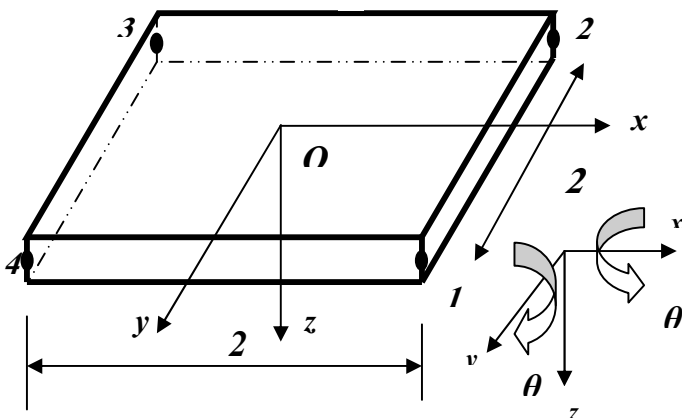

Fig. 1 Coordinate system

### III. ADVANTAGEOUS OF THE STRAIN BASED APPROACH

Direct interpolation based on the strain approach provides a better precision on these values and on constraints and displacements (obtained by integration); compared to the classic formulation where deformations are obtained by derivation of the chosen displacement fields.

The main advantages of this approach are [11], [12]:

- Easy satisfaction of the main two convergence criteria bound directly to strains (constant strains and rigid body movement).
- Effortlessly decoupling of the various strain components (a field of uncoupled displacements generates coupled strains).
- Possibility of enriching the field of displacements by terms of high order without the introduction of intermediate nodes or of supplementary degrees of freedom (allowing so to treat the problem of locking).

### IV. PRESENTATION OF SOME FINITE ELEMENTS APPLIED TO THE ANALYSIS OF PLATES

#### A. Elements Based On the Displacement Model

This model is the most popular and most developed. In this model, the finite elements are based on an interpolation of the displacements field. The displacements are determined in a single and detailed way in the structure, whereas the stresses are not continuous at the boundaries. Among the finite elements based on this approach are:

a/ ACM: This element Adini et al. [13] and : is a rectangular plate bending element based on the Kirchhoff theory and the displacement formulation. The displacement fields are given by (1):

$$w = \alpha_1 + \alpha_2 x + \alpha_3 y + \alpha_4 x^2 + \alpha_5 xy + \alpha_6 y^2 + \alpha_7 x^3 + \alpha_8 x^2 y + \alpha_9 xy^2 + \alpha_{10} y^3 + \alpha_{11} x^3 y + \alpha_{12} y^3$$

$$\theta_x = \frac{\partial w}{\partial y} = (\alpha_3 + \alpha_5 x + 2\alpha_6 y + \alpha_8 x^2 + 2\alpha_9 xy + 3\alpha_{10} y^2 + \alpha_{11} x^3 + 3\alpha_{12} xy^2) \quad (1)$$

$$\theta_y = -\frac{\partial w}{\partial x} = -(\alpha_2 + 2\alpha_4 x + \alpha_5 y + 3\alpha_7 x^2 + 2\alpha_8 xy + \alpha_9 y^2 + 3\alpha_{11} x^2 y + \alpha_{12} y^3)$$

b/ R4: the rectangular bilinear element based on displacement model, the displacements field is given as follows (2):

$$w = \alpha_1 + \alpha_2 x + \alpha_3 y + \alpha_4 xy$$

$$\beta_y = \alpha_5 + \alpha_6 x + \alpha_7 y + \alpha_8 xy \quad (2)$$

$$\beta_x = \alpha_9 + \alpha_{10} x + \alpha_{11} y + \alpha_{12} xy$$

#### B. Elements Based On the Strain Approach

This approach is based on the calculation of the exact terms representing all the rigid body modes and the other components of the displacement functions; which are based on assumed independent strain functions insofar as it is allowed by the elasticity compatibility (3).

$$\frac{\partial^2 \epsilon_{ij}}{\partial x_k \partial x_l} + \frac{\partial^2 \epsilon_{kl}}{\partial x_i \partial x_j} - \frac{\partial^2 \epsilon_{ik}}{\partial x_l \partial x_j} + \frac{\partial^2 \epsilon_{jl}}{\partial x_i \partial x_k} \quad (3)$$

The following elements are presented:

a/ SBH8 : (Strain Based Hexaedrom 8-node), is a three-dimensional element having eight nodes and 24 degrees of freedom, it is formulated for the analysis of thin and thick plates [11], the displacement fields are given by (4):

$$u = \alpha_1 + \alpha_4 y + \alpha_6 z + \alpha_7 x + \alpha_8 xy + \alpha_9 xz + \alpha_{10} xyz - 0.5\alpha_{12} y^2 - 0.5\alpha_{14} y^2 z - 0.5\alpha_{16} z^2 - 0.5\alpha_{18} yz^2 + 0.5\alpha_{21} z + 0.5\alpha_{23} y + \alpha_{24} yz$$

$$v = \alpha_2 - \alpha_4 x - \alpha_5 z - 0.5\alpha_8 x^2 - 0.5\alpha_{10} x^2 z + \alpha_{11} y + \alpha_{12} xy + \alpha_{13} yz + \alpha_{14} xyz - 0.5\alpha_{17} z^2 - 0.5\alpha_{18} xz^2 + 0.5\alpha_{19} z + \alpha_{20} xz + 0.5\alpha_{23} x \quad (4)$$

$$w = \alpha_3 + \alpha_5 y - \alpha_6 x - 0.5\alpha_9 x^2 - 0.5\alpha_{10} x^2 - 0.5\alpha_{13} y^2 - 0.5\alpha_{14} xy^2 + \alpha_{15} z + \alpha_{16} xz + \alpha_{17} yz + \alpha_{18} xyz + 0.5\alpha_{19} y + 0.5\alpha_{21} x + \alpha_{22} xy$$

b/ SBRP : Strain based rectangular plate bending element, with four nodes and 12 degrees of freedom used for the analysis of thin and thick plates [8], the displacement fields are given by (5):

$$w = \alpha_1 - \alpha_2 x - \alpha_3 y - \alpha_4 \frac{x^2}{2} - \alpha_5 \frac{x^2 y}{2} - \alpha_6 \frac{y^2}{2} - \alpha_7 \frac{xy^2}{2} - \alpha_8 \frac{xy}{2} + \alpha_9 \frac{x}{2} + \alpha_{10} \frac{xy}{2} + \alpha_{11} \frac{y}{2} + \alpha_{12} \frac{xy}{2}$$

$$\beta_x = \alpha_2 + \alpha_4 x + \alpha_5 xy - \alpha_7 \frac{y^2}{2} + \alpha_8 \frac{y}{2} + \frac{\alpha_9}{2} + \alpha_{10} \frac{y}{2} - \alpha_{12} \frac{y}{2} \quad (5)$$

$$\beta_y = \alpha_3 - \alpha_5 \frac{x^2}{2} + \alpha_6 y + \alpha_7 xy + \alpha_8 \frac{x}{2} - \alpha_{10} \frac{x}{2} + \frac{\alpha_{11}}{2} + \alpha_{12} \frac{x}{2}$$

c/ SBRPS: another version of the plate bending element(SBRP) developed by Hamadi and Derbane [9] the displacement fields are given by (6):

$$w = \alpha_1 - \alpha_2 x - \alpha_3 y - \alpha_4 \frac{x^2}{2} - \alpha_5 \frac{x^2 y}{2} - \alpha_6 \frac{y^2}{2} - \alpha_7 \frac{xy^2}{2} - \alpha_8 \frac{xy}{2} + \alpha_9 \frac{4x}{5} + \alpha_{10} \frac{xy}{2} + \alpha_{11} \frac{4y}{5} + \alpha_{12} \frac{xy}{2} \quad (6)$$

$$\beta_x = \alpha_2 + \alpha_4 x + \alpha_5 xy - \alpha_7 \frac{y^2}{2} + \alpha_8 \frac{y}{2} + \frac{\alpha_9}{5} + \alpha_{10} \frac{y}{2} - \alpha_{12} \frac{y}{2}$$

$$\beta_y = a_3 - a_5 \frac{x^2}{2} + a_6 y + a_7 xy + a_8 \frac{x}{2} - a_{10} \frac{x}{2} + \frac{a_{11}}{5} + a_{12} \frac{x}{2}$$

d/ SBRPK: Strain based rectangular Kirchhoff plate, with four nodes and 12 degrees of freedom, this element is formulated by Abderrahmani and Hamadi (under publication), and is used for the analysis of thin and thick plates, the displacement fields are given by (7):

$$w = a_1 - a_2 x - a_3 y - a_4 \frac{x^2}{2} - a_5 \frac{x^3}{6} - a_6 \frac{x^2 y}{2} - a_7 \frac{x^3 y}{6} - a_8 \frac{y^2}{2} - a_9 \frac{xy^2}{2} - a_{10} \frac{y^3}{6} - a_{11} \frac{xy^3}{6} - a_{12} \frac{xy}{2} \quad (7)$$

$$\beta_x = a_2 + a_4 x + a_5 \frac{x^2}{2} + a_6 xy + a_7 \frac{x^2 y}{2} + a_8 \frac{y^2}{2} + a_{11} \frac{y^3}{6} + a_{12} \frac{y}{2}$$

$$\beta_y = a_3 + a_6 \frac{x^2}{2} + a_7 \frac{x^3}{6} + a_8 y + a_9 xy + a_{10} \frac{y^2}{2} + a_{11} \frac{xy^2}{2} + a_{12} \frac{x}{2}$$

We should mention that, the evaluation of the element stiffness matrix is summarized with the evaluation of the following well known expressions (8):

$$[K_e] = [A^{-1}]^T \left[ \iint_S [Q]^T [D] [Q] dx dy \right] [A^{-1}] \quad (8a)$$

$$[K_e] = [A^{-1}]^T [K_0] [A^{-1}] \quad (8b)$$

with:

$$[K_0] = \iint_S [Q]^T [D] [Q] dx dy \quad (8c)$$

## V. NUMERICAL APPLICATIONS

### A. Cantilever Beam Subjected to Point Load

This example is well known and used in the literature to test bending elements. This cantilevered beam is loaded by a point load at the free end as shown in Fig. 2. Several aspect ratios of the length (L) to the thickness (h) of the cantilever are considered (L/h=1-100). The geometrical and material properties are given below.

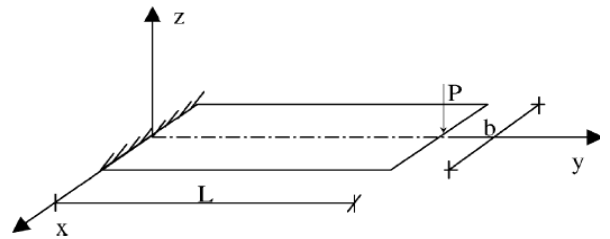

Fig. 2 Cantilever beam under a point load

Data:

Length L=10 m, width b=1 m thickness h = (Variable (0, 1 - 10) m, Young's modulus E=1,2x10<sup>6</sup> N/m<sup>2</sup> and Poisson's ratio ν = 0, P = 0,1 N

The analytical solution of the vertical displacement W at the free end is given by (9):

$$W = \frac{4PL^3}{Eb h^3} \left[ 1 + \frac{1}{2k} \left( \frac{h}{L} \right)^2 \right] \quad (9)$$

If we neglect the shear effect ( $\frac{h}{L} \ll 1$ ), the analytical solution of the vertical displacement W at the free end is given by:  $w = \frac{4PL^3}{Eb h^3}$ , the results obtained for the vertical displacement at the free end are presented in Table I.

TABLE I  
 INFLUENCE OF L/H ON THE MAXIMUM DISPLACEMENT (k=5/6)

$\frac{L}{h}$	W					
	1	2	4	5	10	100
ACM	$3.34 \times 10^{-7}$	$2.68 \times 10^{-6}$	$2.14 \times 10^{-5}$	$4.18 \times 10^{-5}$	$3.44 \times 10^{-4}$	0.3344
R4	$5.3 \times 10^{-7}$	$3.0 \times 10^{-6}$	$2.1 \times 10^{-5}$	$3.9 \times 10^{-5}$	$2.4 \times 10^{-4}$	0.0078
SBH8	$5.3 \times 10^{-7}$	$3.1 \times 10^{-6}$	$2.2 \times 10^{-5}$	$4.3 \times 10^{-5}$	$3.3 \times 10^{-4}$	0.3325
SBRP	$5.3 \times 10^{-7}$	$3.1 \times 10^{-6}$	$2.2 \times 10^{-5}$	$4.3 \times 10^{-5}$	$3.3 \times 10^{-4}$	0.3325
SBRPS	$5.32 \times 10^{-7}$	$3.06 \times 10^{-6}$	$2.19 \times 10^{-5}$	$4.23 \times 10^{-5}$	$3.32 \times 10^{-4}$	0.3334
<b>SBRPK</b>	$3.33 \times 10^{-7}$	$2.66 \times 10^{-6}$	$2.13 \times 10^{-5}$	$4.16 \times 10^{-5}$	$3.33 \times 10^{-4}$	0.3333
Analy solution	$5.33 \times 10^{-7}$	$3.1 \times 10^{-6}$	$2.2 \times 10^{-5}$	$4.3 \times 10^{-5}$	$3.3 \times 10^{-4}$	0.3333

### B. Simply Supported Plate with Concentrated Load

The plate is subjected to a point load P applied at the center of the plate. The convergence results obtained for maximum displacement at the center of the plate are given in Table II and compared with the Kirchhoff solution [14] and those given by other elements. The geometrical and material properties are: L=20, h=0.2, P=1, ν = 0.3, E=10<sup>6</sup>

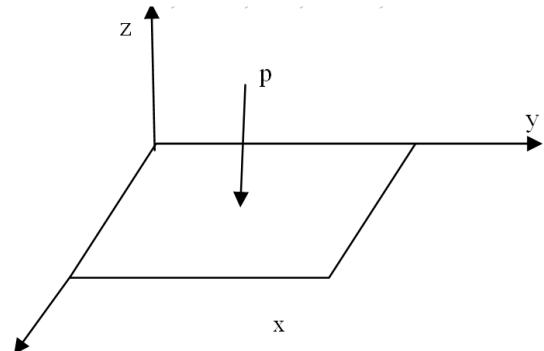

Fig. 3 Simply supported square plate

TABLE II  
CONVERGENCE VERTICAL DISPLACEMENT

Mesh	Maximum vertical displacement ( $(\frac{wD}{PL^2}) \cdot 10000$ )				
	ACM	SBH8	SBRP	SBRPS	SBRPK
2 × 2	123,553	25.566	18,284	17,09	139,089
4 × 4	118,297	85.63	84,496	83,71	123,313
8 × 8	116,703	111,674	111,641	101,80	118,294
10 × 10	116,465	113,756	113,74	117,96	117,542
Kirchhoff solution			<b>116,0</b>		

Analytical solution (Kirchhoff solution) is given by:

$$(w_{ref} = 11.6 \cdot 10^{-3} \frac{PL^2}{D})$$

*C. An Elongated Thin Cantilever Beam Subjected to End Shear:*

An elongated thin cantilever beam subjected to end shear. This is a standard problem to test finite element accuracy. Young's modulus and Poisson's ratio are denoted by E and  $\nu$ . These parameters and the mesh division are shown in Fig. 4, while the results are presented in Table III.

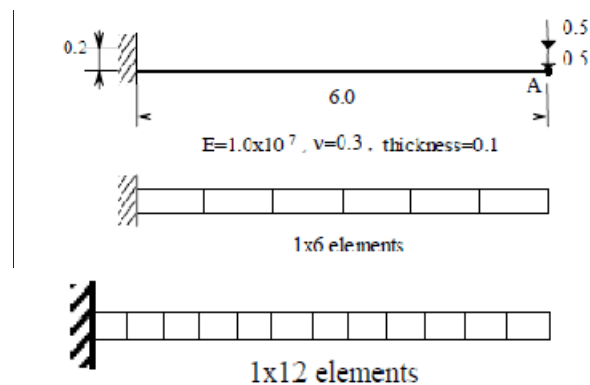

Fig. 4 An elongated thin cantilever beam subjected to end shear

TABLE III  
NORMALIZED DEFLECTION AT POINT A OF A THIN CANTILEVER BEAM UNDER SHEAR

Mesh	Normalized tip deflection	
	1 × 6	1 × 12
SBRPK	<b>0.986</b>	<b>0.992</b>
Analytical Solution	1.000(0.1081)	

VI. CONCLUSION

From the numerical applications and the results obtained for different type of elements used, the following conclusions can be drawn:

The formulated element "SBRPK" is very powerful for the analysis of thin plate compared to other elements based on displacement formulation (ACM and R4) (see Table I).

The element "SBRPK" converge rapidly for thin plate compared to other strain based elements (SBPR, SBH8 and SBRPS) which confirm its efficiency for thin plates (see Table II)

The plate bending elements SBRP, SBRPS and SBH8 have similar behaviour, and they can be used for both thin and thick

plates. Furthermore; they are free from any shear locking since they converge to the Kirchhoff solution for thin plates.

The efficiency of the strain based elements has been demonstrated, and the advantageous of using the strain approach are confirmed.

REFERENCES

- [1] O. C. Zienkiewicz and R.L. Taylor, "The finite element method in solid and fluid mechanics, dynamics and nonlinearity", Vol. II, (Mc Graw Hill, New York, 1991).
- [2] R.H. Gallagher, "Introduction to the finite elements" .Printice-Hall, Inc., Englewood Cliffs, (New Jersey, USA, 1975).
- [3] Belarbi M.T. and Maalem T., On improved rectangular finite element for plane linear elasticity analysis, Revue européenne des éléments finis, Vol. 14, N° 8, 2005.
- [4] Djoudi M.S. and Bahai H., A shallow shell finite element for the linear and nonlinear analysis of cylindrical shells. Engineering structures (25): 769- 778, 2003.
- [5] Djoudi M.S. and Bahai H., A cylindrical strain-based shell element for vibration analysis of shell structures. Finite Elements in Analysis and Design, 40: 1947-1961.
- [6] Belarbi M.T. and Maalem T., On improved rectangular finite element for plane linear elasticity analysis, Revue européenne des éléments finis, Vol. 14, N° 8, 2005.
- [7] D. Hamadi, M. Mellas, R. Chebili and M. Nouaouria, "An efficient quadrilateral membrane element for civil engineering analysis", World Journal of Engineering, Vol. 4 No.1, 2007, pp. 54 -65.
- [8] Belounar L. and Guenfoud M., A new rectangular finite element based on the strain approach for plate bending, Thin-Walled Structures 43 (2005) 47- 63.
- [9] Hamadi D., Derbane S. and Ounis A., "Formulation of A new plate bending finite element based on the strain approach, international conference on applied and computational mathematics October 2012 Ankara.
- [10] Batoz JL, Daht G. Mode'lisatlon des structures par e'lements finies. Poutres et plaques, vol. 2. Paris: Hermes; 199.
- [11] Belarbi M.T. et Charif A., Développement d'un nouvel élémenthexaédrique simple basé sur le modèle en déformation pour l'étude des plaques minces et épaisses, Revue Européenne des éléments finis, Vol. 8, N° 2, pp. 135-157, 1999.
- [12] D. Hamadi, "Analysis of structures by non-conforming finite elements", PhD Thesis, Civil engineering department, Biskra University, Algeria, 2006, pp. 130.
- [13] A. Adini. and R.W. Clough., "Analysis of plate bending by the finite element method", Report to the Nat. Sci. Found., U.S.A., G 7337, 1961.
- [14] Timoshenko S, Woinowsky-Krieger S. Theory of plates and shells. London: McGraw-Hill; 1959.

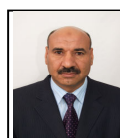

**HAMADI Djmal** was born in Batna, Algeria, in 1959. He earned M.Sc degree in Civil Eng. Structures, at City University, School of engineering and mathematics, London, United Kingdom, in 1989 and PhD in Civil Eng. Structures at Biskra University, Igeria in 2006. He has more than 24 years of teaching experience and currently works as a Professor at the civil and hydraulics department, Faculty of Sciences and Technology, and a researcher in the Laboratory of Civil Engineering, Hydraulics, Development and Durability, Biskra University, Algeria.

Prof. Djmal has published more than 25 research papers in International association of Engineering conference proceedings and international journals. His research interests include numerical analysis of structures, finite element method, strain based approach, structures modelling and FORTRAN programming finite elements.

Prof. Djmal became a Member of IAENG since 2008.

**ABDERRAHMANI Sifeddine** was born in 1989 in Algeria, He earned Master degree in civil Eng. Design and calculation of structures at Biskra University in 2012. Currently he is pursuing in PhD level at Biskra University, modeling of plates by finite element method.

**MAALEM Toufik** has more than 20 years of teaching experience and currently works a senior lecturer at Batna university and a as a director of a Laboratory of Civil Engineering, Batna university, Algeria.

Dr. Toufik has published more than 10 research papers in International Engineering conference proceedings and international journals. His research interests include finite elements analysis of plates and shells, computer programming with FORTRAN language.

**TEMAMI Oussama** was born in May 1987 in Algeria, He earned Master degree in civil Eng. Design and calculation of structures at Biskra University in 2011. Currently his pursuing in PhD level at Biskra University, numerical modeling shell structures.