

A Comparative Study between Displacement and Strain Based Formulated Finite Elements Applied to the Analysis of Thin Shell Structures

Djamal Hamadi, Oussama Temami, Abdallah Zatar, Sifeddine Abderrahmani

Abstract—The analysis and design of thin shell structures is a topic of interest in a variety of engineering applications. In structural mechanics problems the analyst seeks to determine the distribution of stresses throughout the structure to be designed. It is also necessary to calculate the displacements of certain points of the structure to ensure that specified allowable values are not exceeded. In this paper a comparative study between displacement and strain based finite elements applied to the analysis of some thin shell structures is presented. The results obtained from some examples show the efficiency and the performance of the strain based approach compared to the well known displacement formulation.

Keywords—Displacement formulation, Finite elements, Strain based approach, Shell structures.

I. INTRODUCTION

CONSIDERABLE attention has been given to applying the finite element method in the analysis of curved structures. Grafton and Strome [1] developed conical segments for the analysis of revolution shells. Later Jones and Strome [2] modified the method and used meridional elements which were found to lead to considerably improved results for the stresses. Curved rectangular and cylindrical shell elements were also developed by Connor and Brebbia [3] Cantin and Clough [4] and Sabir and lock [5]. Several shell elements have been developed to analyze shell structures of different shape, except the last one, all previous elements are developed using the displacement formulation. Meanwhile, at Cardiff University (UK), a different approach has been used to the development of curved and shell elements by Sabir et al. [6]-[13]. This approach is based on the development of displacement functions based on the strain approach and satisfying the compatibility equation. An element for arches deforming in the plane, containing the curvature and out of the plane curvature [6] and [7] as well as for cylindrical shells [8]-[10] were first developed. This approach was further extended to develop a general quadrilateral cylindrical element and was used to investigate the stress concentration problems in cylinders having circular and elliptical holes, and also to

obtain a solution to the problem of normally intersecting cylinders [11]. Recently, Sabir and Ramadhani [12] developed an even simpler curved element for general shell analysis. The element is rectangular in plan and has only the essential five external nodal degrees of freedom at each of the four corner nodes. The formulated element was tested by applying it the analysis of cylindrical as well as spherical shells [13] and the results show a high degree of accuracy and can converge to the correct solution with relatively coarse meshes. Some other elements for shells and three-dimensional elasticity have been also developed by Djoudi et al. [14], Sabir et al. [15], Belarbi et al. [16] and Assan [17]; from the validation tests, these elements have been shown to produce results of an acceptable degree of accuracy without the use of large number of elements. Lately, Djoudi and Bahai have developed a new strain based shell element for the linear and nonlinear analysis of cylindrical shells [18] and two other elements for vibration analysis of shell structures [19], [20]. The effectiveness of these elements was demonstrated and good convergence was also observed. Most recently, a new flat shell element was formulated by Hamadi et al. [21]; it is a quadrilateral element obtained by the superposition of the Q4SBE1 (quadrilateral strain based element) membrane strain based element [22] with the ACM standard plate bending element [23], [24]. The performance of the developed shell element is evaluated on standard test problems. Finally, the main objective of this paper is to present the advantageous and efficiency of the shell finite elements based on the strain approach compared to other displacement elements, and this is through some validation tests.

II. PRESENTATION OF DIFFERENT FORMULATIONS

According to the choice of the interpolation field, several models of the finite elements can be generated which are [25]:

A. Displacement Model

This model is the most popular formulation. In this model, the finite elements are based on an interpolation of the displacements field. The displacements are determined in a single and detailed way in the structure, whereas the stresses are not continuous at the boundaries [26].

B. Stress Model

In this model the element is formulated on the base of stress field approximation only.

Djamal Hamadi, Oussama Temami, and Seif Eddine Abderrahmani are with laboratory of Civil Engineering, Hydraulics, Development and Durability, Department of Civil Engineering and Hydraulics, Biskra University, B.P. 145 RP, 07000 Biskra, Algeria (e-mail: d.hamadi@univ-biskra.dz, o.temami@univ-biskra.dz, abderrahmani_1989@yahoo.com).

Abdallah Zatar is with Civil Engineering and Hydraulics Department Faculty of Sciences and Technology, Biskra University B.P. 07000, Algeria (e-mail: abdullah_zatar@yahoo.fr).

C. Mixed Model

This model is based on two independent interpolations of two or more various unknown fields, generally the displacements fields and stresses fields within the element. This model takes the unknown parameters of these fields as degrees of freedom.

D. Hybrid Model

This model takes in consideration an assumed stress distribution within the element and assumed displacements along its edges.

E. Strain Based Approach

This approach is based on the calculation of the exact terms representing all the rigid body modes and the other components of the displacement functions; which are based on assumed independent strain functions insofar as it is allowed by the compatibility equations.

III. ADVANTAGEOUS OF THE STRAIN BASED APPROACH

Direct interpolation based on the strain approach provides a better precision on these values and on constraints and displacements (obtained by integration); compared to the classic formulation where deformations are obtained by derivation of the chosen displacement fields.

The main advantages of this approach are [27], [28]:

- 1) Easy satisfaction of the main two convergence criteria bound directly to strains (constant strains and rigid body movement).
- 2) Effortlessly decoupling of the various strain components (a field of uncoupled displacements generates coupled strains).
- 3) Possibility of enriching the field of displacements by terms of high order without the introduction of intermediate nodes or of supplementary degrees of freedom (allowing so to treat the problem of locking).

IV. PRESENTATION OF SOME DEVELOPED FINITE ELEMENTS BASED ON THE STRAIN APPROACH

A. Hazim Element

A strain-based hyper finite element is developed by Hazim [29]. This element is rectangular in plan with corner nodes only and six degrees of freedom at each node. These degrees of freedom are taken to be the essential external degrees of freedom namely $u, y, w, \partial w / \partial y$ and $\partial w / \partial x$ with an additional degree of freedom representing the in plane rotation associated with plane membrane elasticity ϕ represented by:

$$\phi = 1/2 \left(\frac{\partial v}{\partial x} - \frac{\partial u}{\partial y} \right) \quad (1)$$

B. Mousa and El Naggar Element

A spherical shell rectangular strain-based finite element was developed also by A.I. Mousa and M.H. El Naggar [30], using shallow shell formulations. The element has six degrees of freedom at each corner node, the essential five external degrees of freedom as well as an additional sixth degree of

freedom representing the in-plane rotation. This element can be used in conjunction with arched beam elements having all the essential six degrees of freedom. This element is applied to the analysis of shell roof with diagonal arched beams, acceptable results are obtained.

C. Djoudi and Bahai Element

A cylindrical strain-based shell element for vibration analysis of shell structures was developed by Djoudi and Bahai [19]. This element have only five degrees of freedom at each of the four corners, $u, v, w, \partial w / \partial x$ and $\partial w / r \partial \theta$. Therefore, the shape functions should contain 20 independent constants. First the displacement fields are:

$$u = a_7 x + a_8 r x \theta - a_{10} r^2 \theta^2 + a_4 r \theta / 2 - a_4 r^3 \theta / 24 - a_4 r^4 \theta^3 / 120 - a_4 r^2 \theta^3 / 12 \quad (2)$$

$$v = -a_4 x^2 / 2 + a_4 r \theta + a_4 r x \theta + a_4 x / 2 + a_4 r^2 \theta^3 / 6 + a_4 r^2 x \theta^3 / 6 + a_4 r^3 \theta^3 / 24 + a_4 r^3 x \theta^3 / 24 + a_4 r x \theta^3 / 4 \quad (3)$$

$$w = -a_4 x^2 / 2 - a_4 x^3 / 6 - a_{14} r x^2 \theta / 2 - a_{15} r x^3 \theta / 6 - a_{16} r^2 \theta^3 / 2 - a_{17} r^2 x \theta^3 / 2 - a_{18} r^3 \theta^3 / 6 - a_{19} r^3 x \theta^3 / 6 - a_{20} r x \theta / 2 \quad (4)$$

The complete shape function is the sum of corresponding expressions. Consider the cylindrical element shown in Fig. 1, O is the centre of the element and the origin of the curvilinear co-ordinates x, y and z . It is well known that the stiffness matrix for the element can be written in the form:

$$[K] = [C^{-1}]^T \left\{ \int_{-\alpha}^{\alpha} \int_{-\beta}^{\beta} [B]^T [D] [B] r dx d\theta \right\} [C^{-1}] \quad (5)$$

and the mass matrix can be written as

$$[m] = [C^{-1}]^T \left\{ t p \int_{-\alpha}^{\alpha} \int_{-\beta}^{\beta} [P]^T [P] r dx d\theta \right\} [C^{-1}] \quad (6)$$

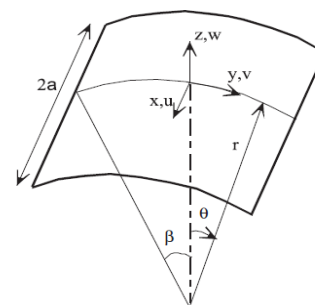

Fig. 1 Shell element

D. Hamadi Et Al Element

Hamadi et al [21] formulated a new shell element baptised ACM_Q4SBE1. It composed by assembling the two elements: Membrane element Q4SBE1 and bending element ACM Fig. 2.

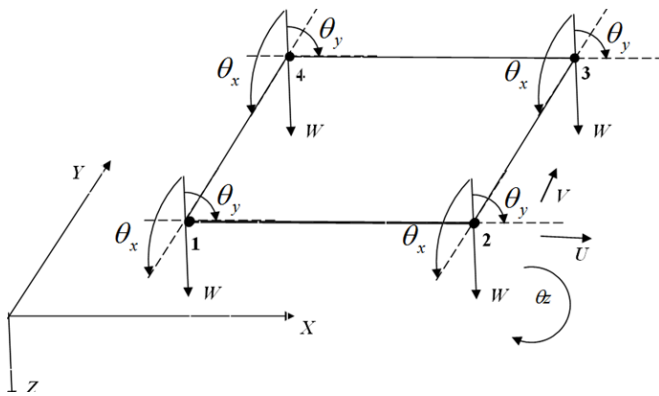

Fig. 2 The shell element ACM_Q4SBE1

The stiffness matrix of the formulated shell element ACM_Q4SBE1 is obtained by using the analytical integration of the membrane and bending stiffness matrices. The calculation of the element stiffness matrix is summarized with the following well known expressions equations (7)-(9):

$$[K_e] = [A^{-1}]^T \left[\iint_S [Q]^T [D] [Q] dx dy \right] [A^{-1}] \quad (7)$$

$$[K_e][K_0] = [A^{-1}]^T [K_e][K_0][A^{-1}] \quad (8)$$

With:

$$[K_0] = \iint_S [Q]^T [D] [Q] dx dy \quad (9)$$

V. PRESENTATION OF SOME NUMERICAL APPLICATIONS

A. Analysis of Gable Roof

A complex type of hyperbolic paraboloid shell which is usually referred to as the gable (or hipped) roof is analyzed by Hazim [29]. This structure is usually constructed by a combination of four hyper shells together with crown and edge beams, as shown in Fig. 3. The dimensions of the gable roof are shown in Fig. 4.

The analysis is carried out using strain based element of Hazim. Due to symmetry of geometry and the uniform loading, only one quarter of the shell needs to be analyzed. Convergence tests were carried out, using the last strain element, for the maximum deflection at the shell crown and the maximum bending moments in the crown and edge beams. The convergence curves for these three values are given in Figs. 5-(7), which show that an 8x8 mesh of the present elements gives results that are in close agreement to those given by Schnobrich [33].

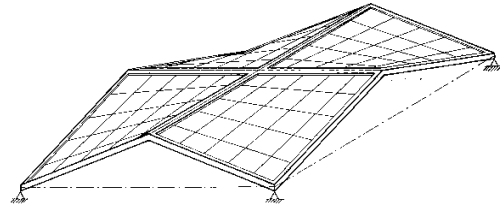

Fig. 3 Gable roof hyperbolic paraboloid shell

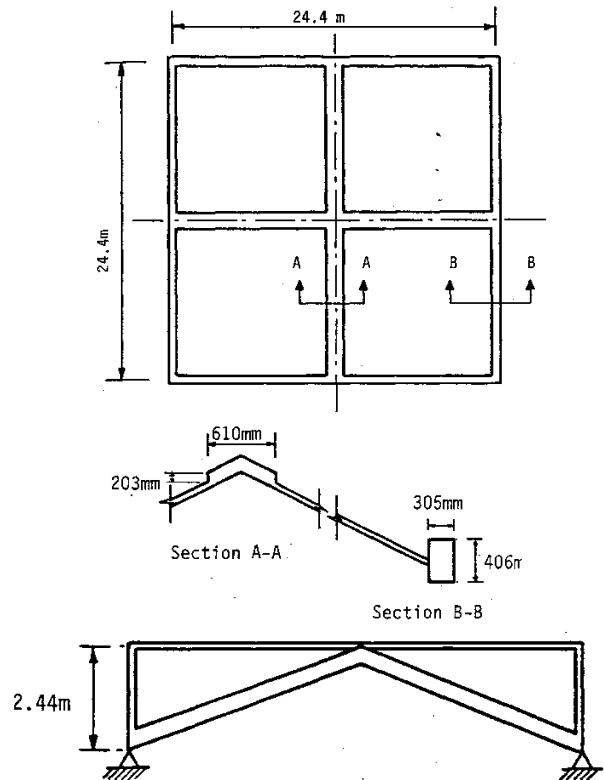

Fig. 4 Gable roof dimensions and configuration

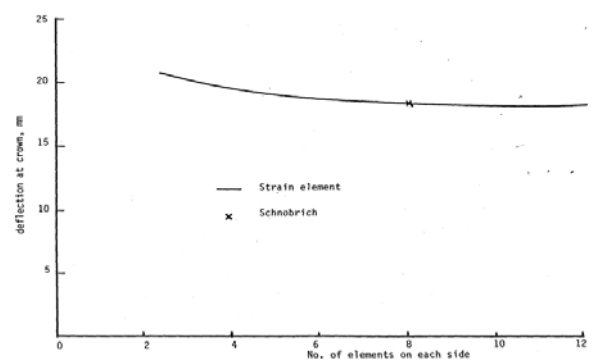

Fig. 5 Gable roof, Convergence of maximum deflection w at crown

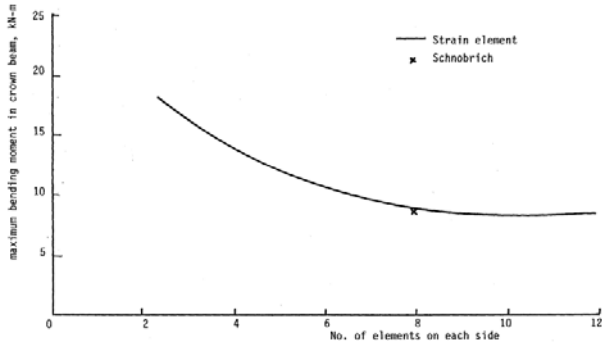

Fig. 6 Gable Roof. Convergence of maximum bending moment in crown beam

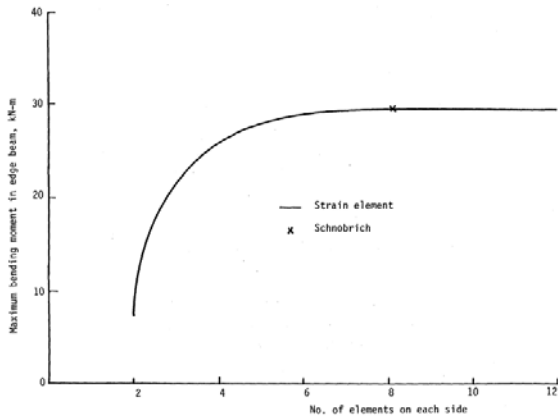

Fig. 7 Gable Roof, convergence of maximum bending moment in edge beam

B. Scordelis-Lo Roof

The next test to be considered which is frequently used to test the performance of shell element is that of Scordelis-Lo roof having the geometry as shown in Fig. 9. The straight edges are free, while the curved edges are supported on rigid diaphragms along their plan. The geometrical and mechanical characteristics are given in Fig. 9. Considering the symmetry of the problem only one quarter of the roof is analysed (part ABCD).

The results obtained by the flat shell elements ACM_Q4SBE1 [22], for the vertical displacement at the midpoint B of the free edge and the centre C of the roof are compared to the reference values based on the deep shell theory. Furthermore, the convergence of this element is also compared to other kinds of quadrilateral shell elements Q4 [24], DKQ24 [31] and ACM-SBQ4 [32]. We should mention that the analytical solution based on the shallow shell theory is given by Scordelis and Lo [34], which is slightly different from the deep shell theory.

Convergence curves (Figs. 9 and 10) show the good contribution of the strain based approach.

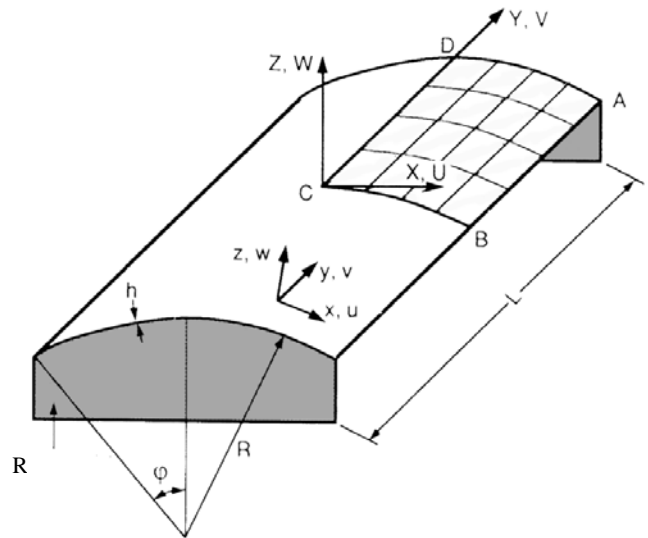

Fig. 8 Scordelis-Lo roof

Data:

$L = 6 \text{ m}$; $R = 3 \text{ m}$; $h = 0.03 \text{ m}$; $\phi = 40^\circ$
 $E = 3 \times 10^{10} \text{ Pa}$; $\nu = 0$; $f_z = -0,625 \times 10^4 \text{ Pa}$

Boundary conditions:

$U = W = \theta Y = 0$ for AD

Symmetry conditions:

$U = \theta Y = \theta Z = 0$ for CD

$V = \theta X = \theta Z = 0$ for CB

Reference value (Deep Shell Theory):

$WB = -3,61 \text{ cm}$; $WC = 0,541 \text{ cm}$

Analytical solution (Shallow Shell theory):

$WB = -3,703 \text{ cm}$; $WC = 0,525 \text{ cm}$

$UB = -1,965 \text{ cm}$; $VA = -0,1513 \text{ cm}$

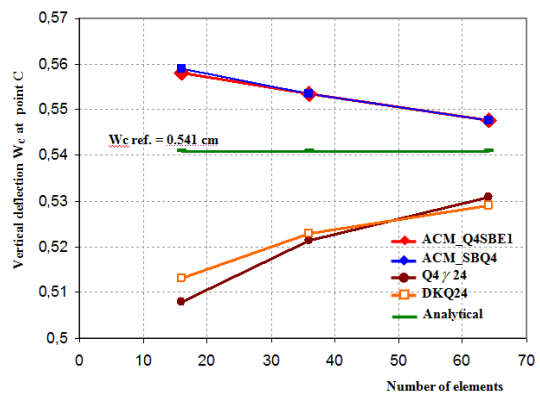

Fig. 9 Convergence curve for the deflection W_c at point C

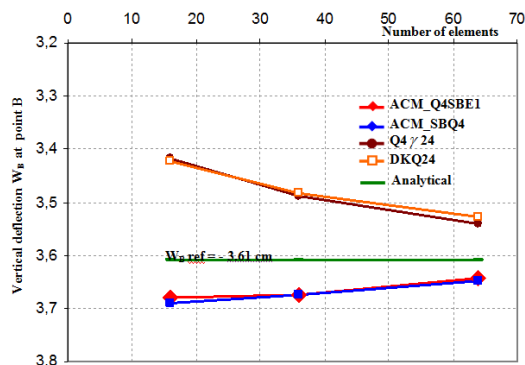

Fig. 10 Convergence curve for the deflection WB at point B

VI. CONCLUSION

From the numerical applications and the results obtained for different finite elements, the following conclusions can be drawn:

Both strain based finite elements ACM_Q4SBE1 and ACM_SBQ4 have similar behavior and they show good converge to the exact solution compared to the corresponding displacements based finite elements Q4/24 and DKQ24.

The results obtained by the use of Hazim element are shown to converge more rapidly, for gable roof example.

The deflections and stresses in the hypar are shown to be highly influenced by the stiffness of the edge beams, and a significant reduction in the values of the maximum membrane stresses in the shell are shown to occur when stiffer edge beams are used.

The efficiency of the strain based elements has been demonstrated, and the advantageous of using the strain approach are confirmed.

REFERENCES

- [1] Grafton, P.E and Strome, D.R. "Analysis of axsymmetric shells by the direct stiffness method" AIAA.Vol 1.10, 1963, PP2342-2347.
- [2] Jones, R.E and Strome, D.R "Direct stiffness method analysis of shells of revolution utilizing curved elements "AIAA J., Vol. 4, 1966, PP1519-1525.
- [3] Brebbia, C and Connor, j.j. "Stiffness matrix for shallow rectangular shell element" J. Eng. Mech. Div. ASCE 93 EMS, 1967, PP43-65.
- [4] Cantin, G. and Clough, R.W. "A curved cylindrical shell finite element". AIAA Journal, vol 6, 1968, PP1057-1062.
- [5] Sabir, A.B. and lock, A.C "A curved cylindrical shell finite element". Int. J. Mech. Sci.14, 1972, P125.
- [6] Ashweil,D.G., Sabir,A.B. and Roberts,T.M. "Further studies in the application of curved finite elements ta circular arches", Int. J. Mech. Sci., vol. 13, 1971, pp. 507-517.
- [7] Sabir, A.B. "Stiffness matrices for general deformation (out of plane and in plane) of curved beam members based on independent strain functions", The Math. of Finite Elements and Applications II, Academic Press, 34, 1975, pp. 411-421.
- [8] Ashweil,D.G. and Sabir,A.B. "A new cylindrical shell finite element based on simple independent strain functions", Int. J. Mech. Sci., vol. 14, 1972, pp. 171-183.
- [9] Sabir,A.B. and Charchafchi,T.A, "Curved rectangular and general quadrilateral shell element for cylindrical shells" The math. of finite elements and applications IV, Academic Press, 1982, pp. 231-239.
- [10] Ashwell,D.G. and Sabir,A.B. "Diffusion of concentrated loads into thin cylindrical shells", The math. of finite elements and appl. III, Academic Press, 33, 1979, pp. 379-389.

- [11] Sabir,A.B. "Strain based finite elements for the analysis of cylinders with holes and normally intersecting cylinders", Nuclear Engg and Design, 76, 1983, pp. 111-120.
- [12] Sabir,A.B. and Ramadhani,F. "A shallow shell finite element for general shell analysis", Proc. 2nd Int. Conf. on variational methods in eng., Univ. of Southampton, 1985 pp. 5-3 to 5-13.
- [13] Sabir,A.B."Strain—based shallow spherical shell element", Proc. Int. Conf. on the mathematics of finite elements and appl., Brunel Univ., 1987.
- [14] Djoudi M.S. & Sabir A.B., Finite element analysis of singly and doubly curved dams of constant or variable thickness. Thin-walled structures (21): 279- 289, 1995.
- [15] Sabir A.B. & Moussa A.I., Finite element analysis of cylindrical-conical storage tanks using strain-based elements. Structural Engineering Review (8) 4: 367-374. 1996.
- [16] Belarbi M.T. et Charif A., Développement d'un nouvel élément hexaédrique simple basé sur le modèle en déformation pour l'étude des plaques minces et épaisses, Revue Européenne des éléments finis, Vol. 8, N° 2, pp. 135-157, 1999.
- [17] Assan A.E., Analysis of multiple stiffened barrel shell structures by strain-based finite elements. Thin-walled structures (35): 233-253, 1999.
- [18] Djoudi M.S. & Bahai H., A shallow shell finite element for the linear and nonlinear analysis of cylindrical shells. Engineering structures (25): 769- 778, 2003.
- [19] Djoudi M.S. & Bahai H., A cylindrical strain-based shell element for vibration analysis of shell structures. Finite Elements in Analysis and Design, 40: 1947-1961. 2004.
- [20] Djoudi M.S. & Bahai H., Strain- based finite element for the vibration of cylindrical panels with openings. Thin-walled structures (42): 575-588, 2004.
- [21] D. Hamadi, R. Chebili and M. Mellas: Numerical and Experimental Investigation of an Elliptical Paraboloid Shell Model. Computer Technology and Application, 6 Vol. 2 No 4 April 2011, pages 324-328, Editor David Publishing Company, ISSN: 1934-7332 (Print), ISSN: 1934-7340 (Online). Website: www.davidpublishing.com
- [22] D. Hamadi, M. Mellas, R. Chebili and M. S. Nouaouria, "An efficient quadrilateral membrane element for civil engineering analysis", World Journal of Engineering, Vol 4 N°. 1, 2007, pp 54-65.
- [23] A. Adini. and R.W. Clough., "Analysis of plate bending by the finite element method", Report to the Nat. Sci. Found., U.S.A., G 7337, 1961.
- [24] R.J. Melosh, "Basis of derivation of matrices for the direct stiffness method", J.AIAA Vol. 1 N7, 1963, pp. 1631-1637.
- [25] Dhatt G ,and Touzot G; "une présentation de la méthode des élement finis ", Eds Maloine, Paris,1984.
- [26] Fraeijs de veubeke B ;"Les connexions cinématiques co-déformables des éléments de coques plans" , Univ de Liège,1974.
- [27] Belarbi M.T. et Charif A., Développement d'un nouvel élément hexaédrique simple basé sur le modèle en déformation pour l'étude des plaques minces et épaisses, Revue Européenne des éléments finis, Vol. 8, N° 2, pp. 135-157, 1999.
- [28] D. Hamadi, "Analysis of structures by non-conforming finite elements", PhD Thesis, Civil engineering department, Biskra University, Algeria, 2006, pp. 130.
- [29] F.E Hazim, "Finite element analysis of shell structures"; University of Wales College of Cardiff, Phd Thesis 1989.
- [30] A.I. Mousa and M.H. El Naggar." Shallow Spherical Shell Rectangular Finite Element for Analysis of Cross Shaped Shell Roof ", *Electronic Journal of Structural Engineering*, 7(2007).
- [31] Batoz J.L. et Dhatt G., Modélisation des structures par éléments finis, Vol. 3 : coques, Eds Hermès, Paris, 1992.
- [32] M.T. Belarbi , "Développement de nouveaux éléments finis bases sur le modèle en déformation. Application linéaire et non linéaire". *Thèse de Doctorat d'état, Université de Constantine, Algérie*, 2000.Scordelis
- [33] Schnobrich,W.C. "Stresses in gable roof H.P. Shells", Bull. Int. Assoc. for shells and spatial structures, 1977.
- [34] A.C. Scordelis A.C. and Lo K.S., Computer analysis of cylindrical shells, J. Amer. Concrete Institute Vol. 61, pp. 539-561, 1969. *Journal of Structural Engineering*, 7(2007).



Hamadi Djamel was born in Batna, Algeria, in 1959. He earned M.Sc degree in Civil Eng. Structures, at City University, School of engineering and mathematics, London, United Kingdom, in 1989 and PhD in Civil Eng. Structures at Biskra University, Algeria in 2006. He has more than 24 years of teaching experience and currently works as a Professor at the civil and hydraulics department, Faculty of Sciences and Technology, and a researcher in the Laboratory

of Civil Engineering, Hydraulics, Development and Durability, Biskra University, Algeria.

Prof. Djamel has published more than 25 research papers in International association of Engineering conference proceedings and international journals. His research interests include numerical analysis of structures, finite element method, strain based approach, structures modelling and FORTRAN programming finite elements.

Prof. Djamel became a Member of IAENG since 2008.



Temami Oussama was born in May 1987 in Algeria, He earned Master degree in civil Eng. Design and calculation of structures at Biskra University in 2011. Currently he is pursuing in PhD level at Biskra University, numerical modeling shell structures.



Zatar Abdallah has more than 27 years of teaching experience and currently works as Vice Director of Civil and Hydraulics Department and a senior lecturer at Faculty of Sciences and Technology, and a researcher in the Laboratory of Civil Engineering, Biskra University, Algeria.

Dr. Abdallah has published more than 15 research papers in International Engineering conference proceedings and international journals. His research interests include computer aid design, finite element method and local materials.

Abderrahmani Sifeddine was born in 1989 in Algeria, He earned Master degree in civil Eng. Design and calculation of structures at Biskra University in 2012. Currently he is pursuing in PhD level at Biskra University, modeling of plates by finite element method.