

Iraqi Short Term Electrical Load Forecasting Based On Interval Type-2 Fuzzy Logic

Firas M. Tuaimah, Huda M. Abdul Abbas

Abstract—Accurate Short Term Load Forecasting (STLF) is essential for a variety of decision making processes. However, forecasting accuracy can drop due to the presence of uncertainty in the operation of energy systems or unexpected behavior of exogenous variables. Interval Type 2 Fuzzy Logic System (IT2 FLS), with additional degrees of freedom, gives an excellent tool for handling uncertainties and it improved the prediction accuracy. The training data used in this study covers the period from January 1, 2012 to February 1, 2012 for winter season and the period from July 1, 2012 to August 1, 2012 for summer season. The actual load forecasting period starts from January 22, till 28, 2012 for winter model and from July 22 till 28, 2012 for summer model. The real data for Iraqi power system which belongs to the Ministry of Electricity.

Keywords—Short term load forecasting, prediction interval, type 2 fuzzy logic systems.

I. INTRODUCTION

THE forecasting is a phenomenon of calculating or estimating a measure in the next coming time periods. Tools and models for accurate forecasting of electric power load are essential to the operation and planning of utility companies. Load forecasts are used by participants in electric energy generation, transmission, distribution, and markets for a variety of decision-making processes, such as economy dispatch, unit commitment, hydro-thermal coordination, transaction evaluation, and expansion planning. There has always been a need for accurate forecasting of future load demands. However, the need has intensified in the last decade due to deregulation of the energy industries in developed countries. As the energy prices may be boosted by a factor of ten or more during periods of peak demands, precise short term load forecasting becomes vitally important to the utilities. Taking into account this as well as rapid fluctuations of demands and abrupt changes in weather condition, access to reliable models for accurate prediction of load demand is essential [1]-[4].

Fuzzy set was first introduced by L.A. Zadeh in 1965 to manipulate the unprobabilistic and uncertainty of data and information. Fuzzy sets and fuzzy logic are the basis of the fuzzy system aiming to mimic how human brain works in manipulating the non-exact information. Therefore, this method is suitable to model complex systems, non-linear and difficult model in uncertainty and this method is implemented on short term load forecasting (STLF). In term of period of

time, STLF is valid for load forecasts within one day to one week ahead of load occurrence [3], [4].

Takagi-Sugeno-Kang (TSK) fuzzy inference systems will be used for developing the IT2 TSK FLS set for the load forecasting. Type-2 FLS (T2 FLS) is an emerging paradigm that uses Type-2 Fuzzy Sets (T2 FS). T2 FSs are characterized by a three dimensional fuzzy MF, that includes a footprint of uncertainty. The footprint of uncertainty and the third dimension of MFs provide additional degrees of freedom that make it possible to directly model and handle uncertainties. Therefore, a T2 FLS has the potential to outperform a Type-1 FLS (T1 FLS) [1]-[5].

Zadeh originally introduced the concept of T2 FSs as an extension of the concept of an ordinary type-1 fuzzy set in 1975. Mendel and Karnik et al. [5]-[9], further developed the theory of T2 FLSs. The structure of rules in the T2 FLS and its inference engine are similar to those in T1 FLS. A T2 FLS includes a fuzzifier, a rule base, fuzzy inference engine, and an output processing unit composed of a type reducer and a defuzzifier (Fig. 1) [1]-[5].

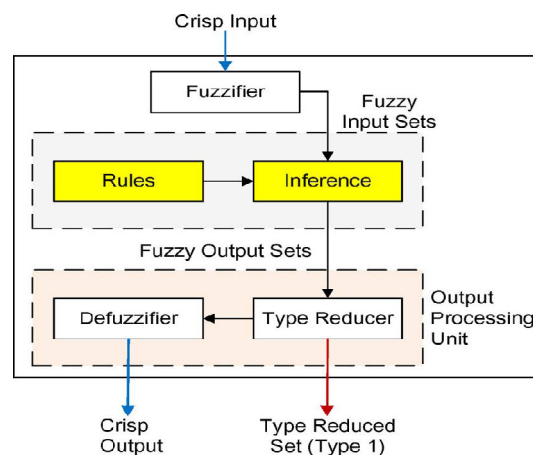

Fig. 1 Structure of a type-2 fuzzy logic system

The computational complexity of general T2 FLSs hinders their widespread use in practical applications. As a restricted class of T2 FLSs, Interval T2 FLSs (IT2 FLSs) [7] were introduced to avoid the massive computational requirement. IT2 FLSs are characterized by secondary MFs that only take the value of 1 over their domain. Such a restriction greatly reduces the computational burden of performing inference compared with general T2 FLSs. T2 FLSs, and in particular IT2 FLSs, have drawn a great deal of attention from both academia and industry in the last few years.

Firas M. Tuaimah and Huda M. Abdul Abbas are with the University of Baghdad. (e mail: Dr.firasmt@gmail.com).

II. INTERVAL TYPE-2 TSK FUZZY LOGIC SYSTEMS

IT2 TSK FLSs are TSK fuzzy models, where antecedent MFs are IT2 FSs or consequent parameters are intervals. As per this definition, three classes of models can be formed [2]:

- A2-C1: Antecedents are IT2 FSs, and consequents are interval T1 FSs.
- A2-C0: Antecedents are similar to the case of A2-C1 model; however, consequent parameters are crisp.
- A1-C1: Antecedents and consequents are both type-1 fuzzy sets.

A. Class A2-C0

In an IT2 TSK FLS (A2-C0) with a rule base of M rules in which each rule has antecedents, let the l th rule be denoted by R^l

$$R^l: \text{If } x_1 \text{ is } \tilde{F}_1^l, x_2 \text{ is } \tilde{F}_2^l, \dots, \text{ and } x_p \text{ is } \tilde{F}_p^l, \text{ then } Y^l = C_0^l + \sum_{i=1}^p C_i^l x_i \quad (1)$$

where $l = 1, \dots, M$, c_0 and c_i are crisp values. \tilde{F}_i^l is the i th IT2 FS ($i = 1, \dots, p$) composed of a lower and upper bound MF

$$\mu_{\tilde{F}_i^l}(x_i) = \left[\underline{\mu}_{\tilde{F}_i^l}(x_i), \overline{\mu}_{\tilde{F}_i^l}(x_i) \right] \quad (2)$$

where the result of the input and antecedent operations (firing strength) is an interval type-1 set, $F^l = [\underline{f}^l, \overline{f}^l]$ where

$$\underline{f}^l(x) = \underline{\mu}_{\tilde{F}_1^l}(x_1) * \underline{\mu}_{\tilde{F}_2^l}(x_2) * \dots * \underline{\mu}_{\tilde{F}_p^l}(x_p) \quad (3)$$

$$\overline{f}^l(x) = \overline{\mu}_{\tilde{F}_1^l}(x_1) * \overline{\mu}_{\tilde{F}_2^l}(x_2) * \dots * \overline{\mu}_{\tilde{F}_p^l}(x_p) \quad (4)$$

where $*$ represents a t-norm. It is assumed that the singleton fuzzifier (the input fuzzy set has only a single point on nonzero membership)

Y^l in (1) is the output from the l th If-Then rule, which is a T1 FS, Y_{cos} which is expressed as [2]

$$Y_{cos} = Y^l = [y_L^l, y_R^l],$$

This interval set is determined by its two end points left and right, y_L and y_R , which corresponds to the centroid of the type-2 interval consequent set, The values of y_L and y_R define the output interval of the type-2 fuzzy system and evaluated as

$$y_L^l = \sum_{i=1}^p c_i^l x_i + c_0^l - \sum_{i=1}^p s_i^l |x_i| - s_0^l \quad (5)$$

$$y_R^l = \sum_{i=1}^p c_i^l x_i + c_0^l + \sum_{i=1}^p s_i^l |x_i| - s_0^l \quad (6)$$

With the exception of c_0 and c_i are crisp values. As parameters of the consequent part of rules are crisp, then

$$y^l = y_L^l = y_R^l$$

The upper and lower firing strength of rule is as defined in (3) and (4). The final output of the IT2 TSK FLS model is obtained through combining the outcomes of M rules [3]

$$Y = [y_L, y_R] = \int_{f^l \in [\underline{f}^l, \overline{f}^l]} \cdot \int_{f^M \in [\underline{f}^M, \overline{f}^M]} 1 / \frac{\sum_{i=1}^M f^i y^i}{\sum_{i=1}^M f^i} \quad (7)$$

the outputs of the inference engine should be type-reduced and then defuzzified. Unfortunately, there is no direct theoretical solution (closed-form formula) for calculation of y_L and y_R in (7). However, they can be calculated using the iterative Karnik-Mendel (KM) procedure for type reduction, which transfers a T2 FS into a T1 FS using the concept of center of sets. In the KM algorithm, the left and right end points of type reduced FS can be defined as

$$y_L = \frac{\sum_{i=1}^L \overline{f}_i^l + \sum_{i=L+1}^M \underline{f}_i^l y^i}{\sum_{i=1}^L \overline{f}_i^l + \sum_{i=L+1}^M \underline{f}_i^l} \quad (8)$$

$$y_R = \frac{\sum_{i=1}^R \underline{f}_i^l + \sum_{i=R+1}^M \overline{f}_i^l y^i}{\sum_{i=1}^R \underline{f}_i^l + \sum_{i=R+1}^M \overline{f}_i^l} \quad (9)$$

From the type-reducer, an interval set Y_{cos} (center of set) obtained, the defuzzified crisp output from the IT2 TSK FLS is the average of y_L and y_R [7]

$$y = \frac{y_L + y_R}{2} \quad (10)$$

B. Number of Fuzzy Network Parameters

There are four inputs to the IT-2 TSK FLS models. These four inputs are the lagged values of loads in recent hours, the current temperature, and the day of the week.

A2-C0 class has in total $p \times n_{MF} \times n_{MFP} + M \times (p + 1)$ premise and consequent parameters, where p is the number of inputs =4, n_{MF} is the number of MFs for each input = 3, M is the number of rules = $n_{MF}^p = (3)^4 = 81$ rule, and n_{MFP} is the number of parameters of an MF =3, the total will be 441 parameters [2].

III. STRUCTURE AND TRAINING OF IT2 TSK FLS MODELS

A. Membership Functions of IT2 TSK FLS

The performance of an IT2 TSK FLS depends on several factors, such as type and quantity of MFs, training algorithm, number of inputs, and the amount of available data for training. One of the most common options for the antecedent MFs is the Gaussian MF with fixed mean and uncertain standard deviations [2]

$$\mu_{\tilde{F}_i^l}(x_i, k) = \exp \left[-\frac{1}{2} \left(\frac{x_{i,k} - m_i^l}{\sigma_i^l} \right)^2 \right] = \mathcal{N}(m_i^l, [\sigma_{i,2}^l]) \quad (11)$$

where $i = 1, \dots, p, l = 1, \dots, M$, and k indicates the sample index. The lower and upper MFs are

$$\underline{\mu}_{\tilde{F}_i^l}(x_i, k) = \mathcal{N}(m_i^l, \sigma_{i,1}^l) \quad (12)$$

$$\bar{\mu}_{F_i^l}(x_{i,k}) = \mathcal{N}(m_i^l, \sigma_{i,1}^l, \sigma_{i,2}^l) \quad (13)$$

Fig. 2 shows the graphical representation of these two MFs for arbitrary chosen values for $m_i^l, \sigma_{i,1}^l$ and $\sigma_{i,2}^l$. The uniformly shaded region is the Footprint of Uncertainty (FOU) for the IT2 Gaussian MF. The uncertain standard deviation helps to capture the non-stationary behavior of the targets.

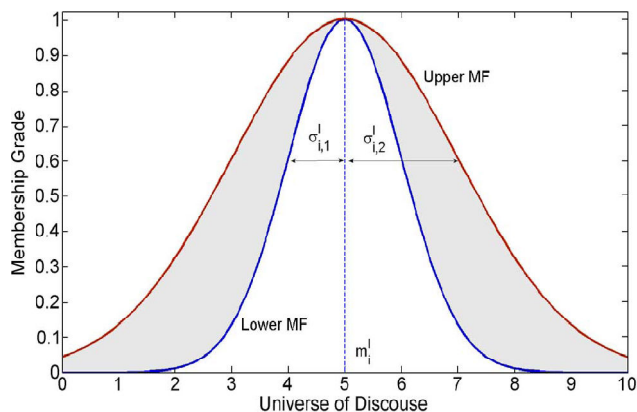

Fig. 2 IT-2 Gaussian MFs with Fixed Mean and Uncertain Standard Deviation

B. Genetic Algorithm for Training

The genetic algorithm (GA) is used for adjusting parameters of the IT2 TSK FLS models. GAs increases the probability of finding the global solution to the minimization problem.

The GA includes three main operators, namely reproduction (elitism), crossover, and mutation. Offspring (new populations) are generated through crossover and mutation. Reproduction is a process in which individual chromosomes are copied according to their scaled fitness function values. Mutation introduces random changes to the chromosomes by altering the value to a gene with a probability called the mutation rate. The crossover operator determines how the GA combines two parents to form an offspring (crossover child) for the next generation.

Once a decision on the number of inputs and MFs per input is made, we can code the IT2 TSK FLS parameters into a chromosome. In each rule, premise parameters (mean and two standard deviations of each input membership function) and consequent parameters are coded as real variables and allowed to take real values. The root mean squared error (RMSE) is considered as the fitness function

$$RMSE = \left(\frac{1}{n} \sum_{i=1}^n (y_i - \hat{y}_i)^2 \right)^{\frac{1}{2}} \quad (14)$$

where y_i and \hat{y}_i are the i th actual and forecasted load. n is also the number of load samples. Parameters of premise and consequent parts of IT2 TSK FLS are randomly initialized. Exploration of solution space continues until termination conditions are met. The maximum number of iterations, a minimum convergence speed, and a satisfactory small value of RMSE are the stopping criteria used in this training. After termination of the GA optimization, test samples are used for

examining performance of the trained model [2]. The procedure for adjusting parameters of IT2 TSK FLS models based on genetic algorithm, can be given within the following steps:

- Step 1. Split samples into training (D_{train}) and test (D_{test}) sets
- Step 2. Initialization of genetic algorithm parameters
- Step 3. Assign new parameters to IT2 TSK FLS model
- Step 4. Calculate the fitness function for the new population
- Step 5. Record the best results depending on termination criterion, if Perform forecasting for samples of D_{test} , else generate a new population and go to step 3 until termination iteration reached.

IV. DATA AND PERFORMANCE EVALUATION

A. Training Data

The training data used in this study covering the period from January 1, 2012 to February 1, 2012 for winter model and the period from July 1, 2012 to August 1, 2012 for summer model. The actual load forecasting period starts from January 22, till 28, 2012 for winter model and from July 22 till 28, 2012 for summer model. The purpose is to forecast the one-week a head loads based on the past observations.

The profile of loads for the covering period is shown in Fig. 3. There is a periodic behavior with rapid fluctuations in the amount of consumed loads. Load peaks occur in summer, where load demand is minimum in winter. Additionally, there is an upward trend in the curve, which indicates monthly growth load demand.

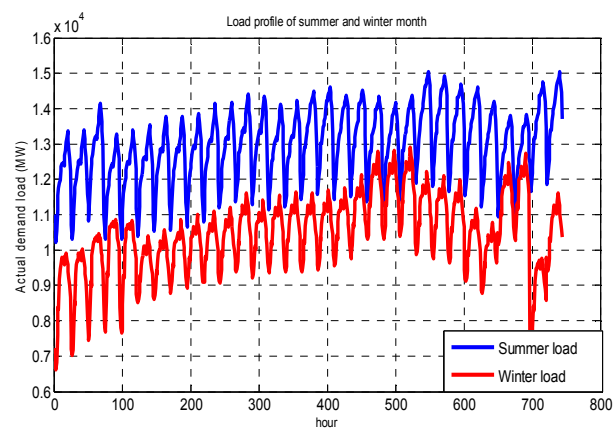

Fig. 3 Hourly Load Profile for Iraqi power System for January and July-2012

The inputs to the IT2 TSK FLS models are listed in Table I. These inputs are the lagged values of loads in recent hours, the current temperature, and the day of the week.

TABLE I
 INPUTS OF IT2 TSK FLS FOR STL

Input	Quantity
Load demand in the last two hours	2
Current temperature	1
Day of the week	1

B. Performance Evaluation

In order to evaluate the performance of the load forecasting model, the mean square absolute percentage error (MAPE) is considered to measure the accuracy of the load forecast performance between the actual load data and the forecasted load data.

The MAPE is defined as follows:

$$MAPE = \frac{1}{N} \sum_{i=1}^N \left[\frac{P_{actual\ i} - P_{predicted\ i}}{P_{actual\ i}} \right] \quad (15)$$

where P_{actual} is the actual load demand, and $P_{predicted}$ is the forecasted or predicted load data of absolute percentage errors.

V. SIMULATION RESULTS AND DISCUSSION

A. IT-2 TSK FLS Technique for Iraqi Power System Load Forecasting for One Week Ahead for Winter and Summer Seasons

This week will be starts from one hour till 168 hour which should be complete one week. The IT-2 TSK FLS was applied to predict the load for each day in the forecasted week, which covers the period from January 22, 2012 till January 28, 2012 for winter season and the period from July 22, 2012 till July 28, 2012 for summer season. The real data for Iraqi network will be taken from Iraqi operation and control center which belongs to the Ministry of Electricity. Figs. 4 and 5 show the actual and the forecasted load for one week ahead for winter and summer seasons. The MAPE term is an index that provides information about the bias of the model and how close forecasts or predictions are to the eventual outcomes. Positive small values indicate under-prediction of the power load, i.e. the predicted values are lower than the observed, and thus the model is 'fail-safe'. An application of IT-2 FLS shows a very good performance, by scoring 0.835% and 0.1566% for winter and summer respectively as illustrated in Table II.

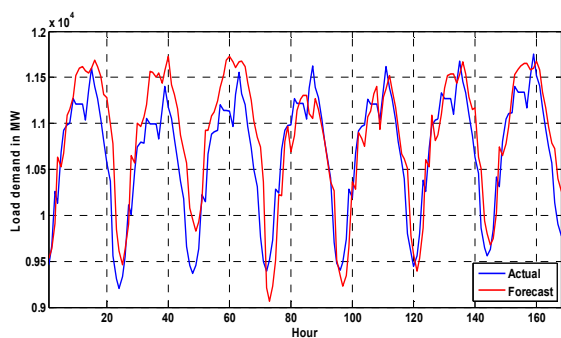

Fig. 4 Actual load & IT-2 FLS Forecasted load in winter season

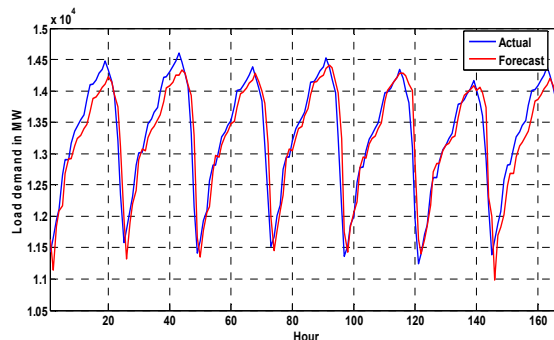

Fig. 5 Actual load & IT-2 FLS Forecasted load in summer season

TABLE II
 MAPE FOR WINTER AND SUMMER FORECASTED WEEK

Winter Season	Summer Season
IT-2 TSK FLS	IT-2 TSK FLS
0.835	0.1566

Figs. 6 and 7 represent scatter plot of the forecasted load demand versus actual load demand by applying IT-2 FLS for both winter and summer season. Scatter plots shows the relationship between two variables by displaying data points on a two-dimensional graph. Scatter plots are especially useful when there are a large number of data points. It is evident that there is a good agreement between the observed and forecasted load demands when using IT-2 FLS method. It is important to notice that all models perform well for loads around 11500 MW for winter and 14000 MW for summer. However, their performance significantly differs as load values become smaller or larger.

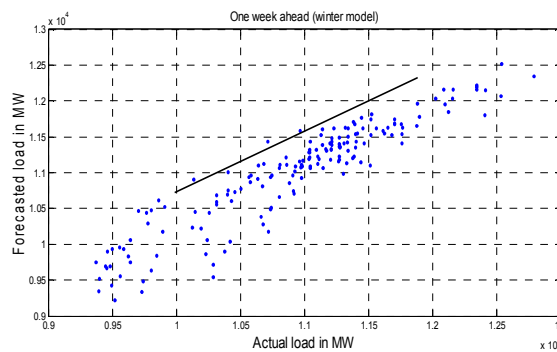

Fig. 6 Scatter plot for the forecasted & actual load in Winter Season

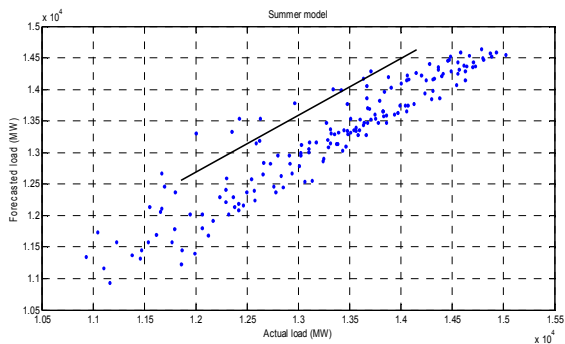

Fig. 7 Scatter plot for the forecasted & actual load in Summer Season

B. Daily Load Forecasting Based on IT-2 TSK FLS Method for Winter Season

The same method will be applied to predict the load for each day in the forecasted week covering the period from January 22, 2012 till January 28, 2012 for winter season. Figs. 8-14 show the actual and the forecasted load of each day in the forecasted week of winter season.

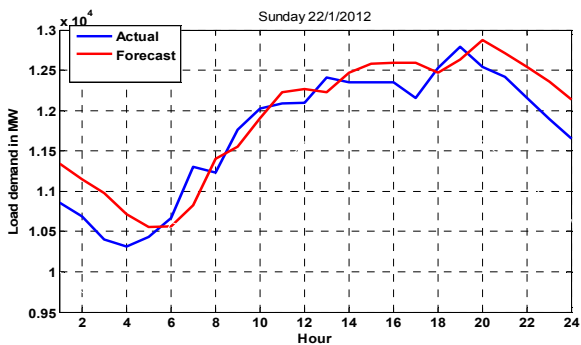

Fig. 8 Load Forecasting for Sunday in winter season based on IT-2 TSK FLS

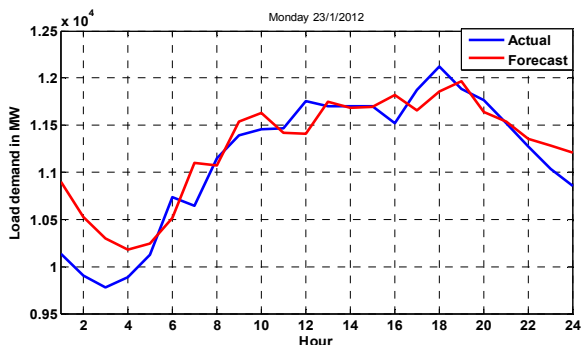

Fig. 9 Load Forecasting for Monday in winter season based on IT-2 TSK FLS

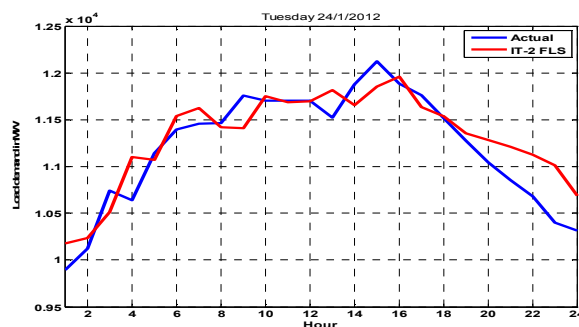

Fig. 10 Load Forecasting for Tuesday in winter season based on IT-2 TSK FLS

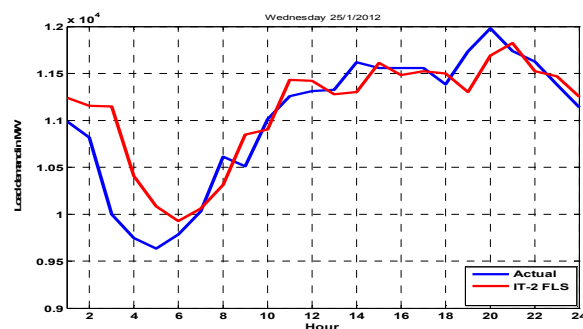

Fig. 11 Load Forecasting for Wednesday in winter season based on IT-2 TSK FLS

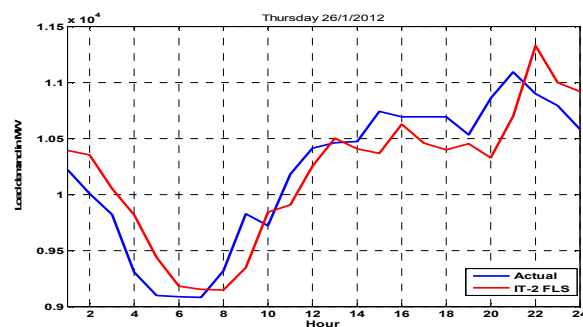

Fig. 12 Load Forecasting for Thursday in winter season based on IT-2 TSK FLS

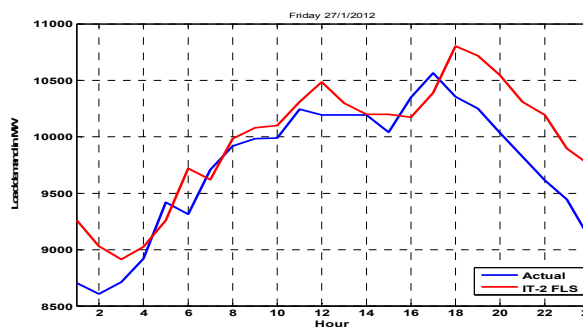

Fig. 13 Load Forecasting for Friday in winter season based on IT-2 TSK FLS

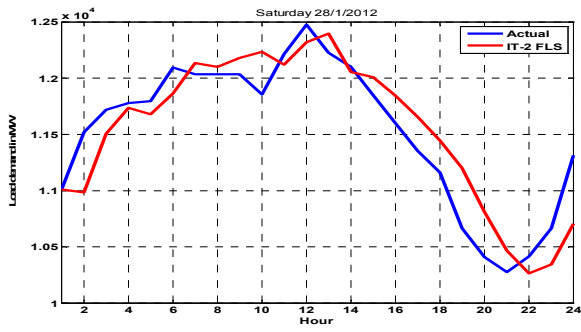

Fig. 14 Load Forecasting for Saturday in winter season based on IT-2 TSK FLS

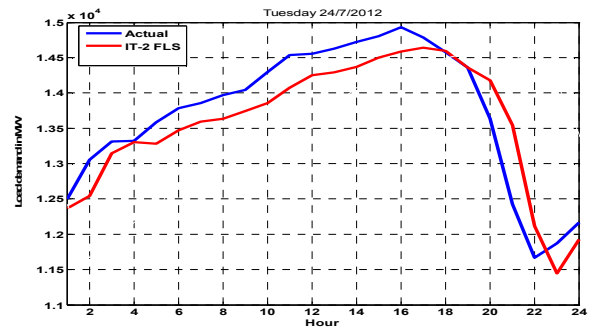

Fig. 17 Load Forecasting for Tuesday in summer season

C. Daily Load Forecasting Based On IT-2 TSK FLS Method for Summer Season

The same method will be applied to predict the load for each day in the forecasted week covering the period from July 22, 2012 till July 28, 2012 for summer season. Figs. 15-21 show the actual and the forecasted load of each day in the forecasted week of summer season.

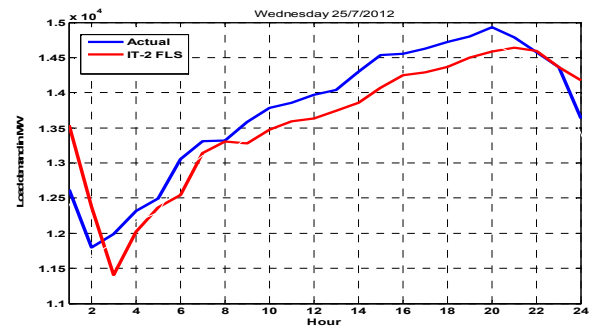

Fig. 18 Load Forecasting for Wednesday in summer season

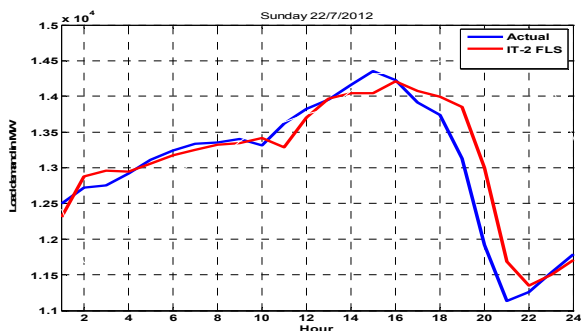

Fig. 15 Load Forecasting for Sunday in summer season

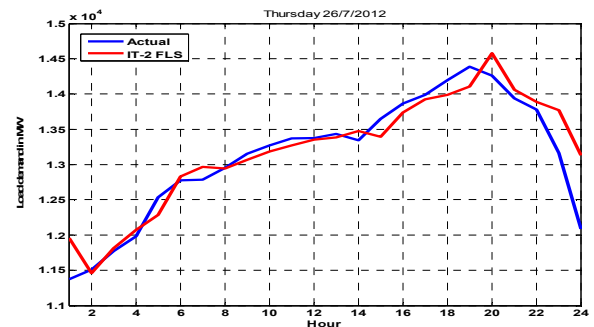

Fig. 19 Load Forecasting for Thursday in summer season

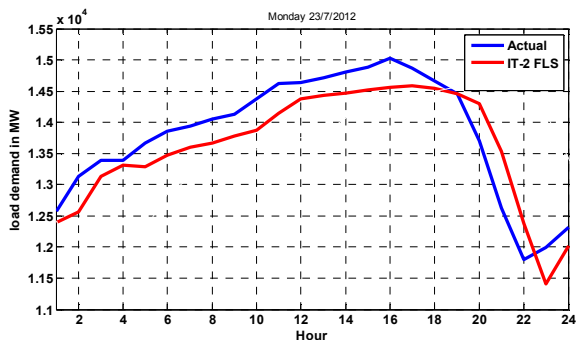

Fig. 16 Load Forecasting for Monday in summer season

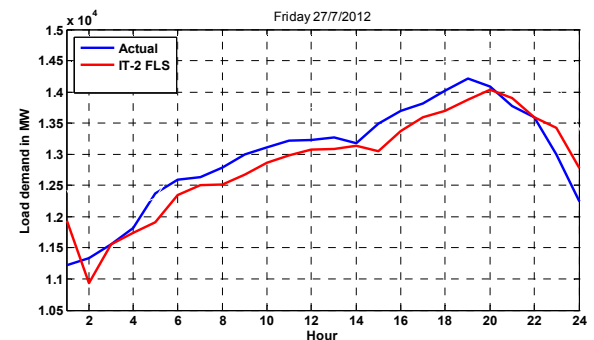

Fig. 20 Load Forecasting for Friday in summer season

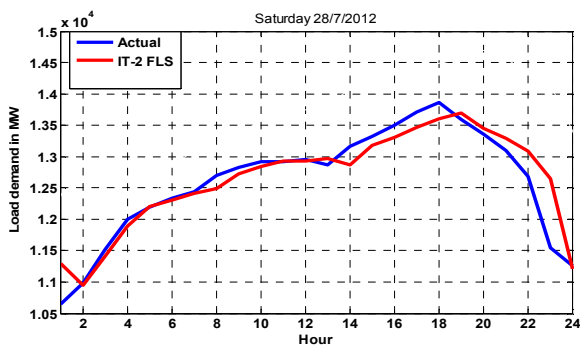

Fig. 21 Load Forecasting for Saturday in summer season

An IT-2 FLS achieved a very good performance results for winter and summer respectively as illustrated in Table III. All of the calculation processes used **m files** and running on Matlab's.

TABLE III
MAPE OF WINTER AND SUMMER FORECASTED DAYS

DAY	Winter Model	Summer Model
Sunday	0.594	1.087
Monday	1.808	1.713
Tuesday	1.064	3.05
Wednesday	0.157	0.39
Thursday	2.874	0.84
Friday	2.109	2.78
Saturday	0.646	4.29

VI. CONCLUSION

In this paper, the interval type-2 TSK fuzzy logic system was used for the problem of short term load forecasting in Iraqi power system. Lagged load demands and weather information are used as inputs to the forecasting model. Developed models are trained using the genetic algorithm. The conclusion of this research is that short term power demand for one week ahead and each day in the covering week period can be accurately forecasted using interval type-2 TSK fuzzy logic systems. The extra degrees of freedom of these models provide the analyzers with sufficient capacity for modeling nonlinear relationships and handling of uncertainties.

REFERENCES

- [1] Agus Dharma, Imam Robandi and Mauridhi Hery Purnomo, "Application of Interval Type-2 Fuzzy Logic System in Short Term Load Forecasting on Special Days" IPTEK, The Journal for Technology and Science, Vol. 22, No. 2, May 2011.
- [2] Abbas Khosravi, Saeid Nahavandi, Doug Creighton, and Dipti Srinivasan, "Interval Type-2 Fuzzy Logic Systems for Load Forecasting: A Comparative Study", IEEE Trans.on power system, Vol. 27, NO. 3, august 2012.
- [3] Abbas Khosravi, Saeid Nahavandi and Doug Creighton, "Short Term Load Forecasting Using Interval Type-2 Fuzzy Logic Systems", IEEE International Conference on Fuzzy Systems, June, 2011.
- [4] Agus Dharma, Imam Robandi and Mauridhi Hery Purnomo, "Application of Short Term Load Forecasting on Special Days Using Interval Type-2 Fuzzy Inference Systems: Study Case in Bali Indonesia", Journal of Theoretical and Applied Information Technology, Vol. 49 No.2, 20th March 2013.

- [5] Jerry M. Mendel, Robert I. John and Feilong Liu, "Interval Type-2 Fuzzy Logic Systems Made Simple", IEEE Trans. On Fuzzy Systems, Vol. 14, No. 6, 2006.
- [6] Qilian Liang and Jerry M. Mendel, "Interval Type-2 Fuzzy Logic Systems: Theory and Design", IEEE Trans. On Fuzzy Systems, Vol. 8, No. 5, 2000.
- [7] Oscar Castillo and Patricia Melin, "Type-2 Fuzzy Logic: Theory and Applications", Studies in Fuzziness and Soft Computing, Vol 223, Springer-Verlag Berlin Heidelberg, 2008.
- [8] Farah N, Khadir M.T., Bouaziz I. and Kennouche, H. "Short-term Forecasting of Algerian Load Using Fuzzy Logic And Expert System", IEEE, 2009.
- [9] Thiag and Yongky Kurniawan, "Electrical Load Time Series Data Forecasting Using Interval Type-2 Fuzzy Logic System", IEEE, 2010.

Firas M. Tuaimah received the B.Sc, M.Sc, and Ph.D. degrees in electrical engineering from the university of Baghdad, college of engineering, electrical department, Iraq in 1997, 2002, and 2006, respectively. From August 2002 till now, he was with the department of electrical engineering, Baghdad University, where he is currently an Assistant Professor and the Continuing Education Unit Director at the college of Engineering. His research interests include power system control, reactive power control, power system stability, reliability, with a large number of published papers.

Huda M. Abdul Abbas received her B.Sc. degrees in electrical the engineering from the university of Baghdad, College of Engineering, Electrical Department, Iraq in 1990, currently she is an M.Sc. student in the electrical Engineering Department.