

Simulation of Die Casting Process in an Industrial Helical Gearbox Flange Die

Mehdi Modabberifar, Behrouz Raad, Bahman Mirzakhani

Abstract—Flanges are widely used for connecting valves, pipes and other industrial devices such as gearboxes. Method of producing a flange has a considerable impact on the manner of their involvement with the industrial engines and gearboxes. By Using die casting instead of sand casting and machining for manufacturing flanges, production speed and dimensional accuracy of the parts increases. Also, in die casting, obtained dimensions are close to final dimensions and hence the need for machining flanges after die casting process decreases which makes a significant savings in raw materials and improves the mechanical properties of flanges. In this paper, a typical die of an industrial helical gearbox flange (size ISO 50) was designed and die casting process for producing this type of flange was simulated using ProCAST software. The results of simulation were used for optimizing die design. Finally, using the results of the analysis, optimized die was built.

Keywords—Die casting, finite element, flange.

I. INTRODUCTION

WITH the growth of technology, various methods of casting have been introduced and used in industries. One of these methods is die casting. Die-casting can be done using a cold chamber (high pressure) or hot chamber (low pressure) process. In high pressure casting process, molten metal is injected into die under high pressure of 2000-20000psi. However, typical injection pressures for a hot chamber die casting machine are between 1000 and 5000 psi. The procedure for filling die cavity in die casting is similar to *permanent mold casting* except that the metal is injected into the mold under high pressure. This results in a more uniform part, generally good surface finish and good dimensional accuracy. For many parts, post-machining can be totally eliminated, or very light machining may be required to bring dimensions to size.

The dies are typically composed of two halves - the cover die, which is mounted onto a stationary platen, and the ejector die, which is mounted onto a movable platen. This design allows the die to open and close along its parting line. Once closed, the two die halves form an internal part cavity which is filled with the molten metal to form the casting. This cavity is formed by two inserts, the cavity insert and the core insert,

which are inserted into the cover die and ejector die, respectively. The cover die allows the molten metal to flow from the injection system, through an opening, and into the part cavity. The ejector die includes a support plate and the ejector box, which is mounted onto the platen and inside contains the ejection system. When the clamping unit separates the die halves, the clamping bar pushes the ejector plate forward inside the ejector box which pushes the ejector pins into the molded part, ejecting it from the core insert. Multiple-cavity dies are sometimes used, in which the two die halves form several identical part cavities (Fig. 1).

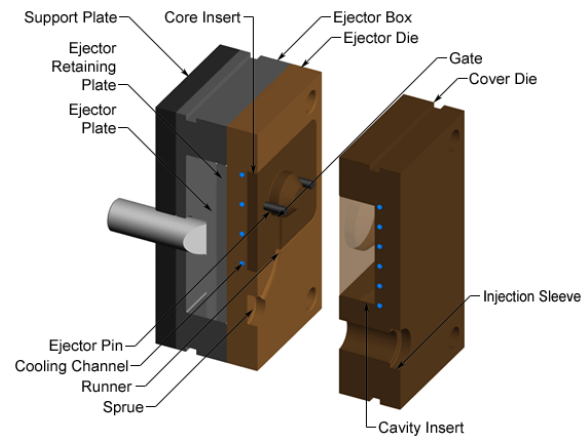

Fig. 1 Die assembly and components (cold chamber) [1]

The first theoretical explanation about the cavity filling in Die casting was given by Frommer and Brandt. Frommer explained the filling the die cavity with alloy as a hydrodynamic streaming without losses by friction. In Frommer analysis, the alloy stream passes through the die cavity and disperses on the wall of the die cavity opposite the gate and fills the die cavity from here. According to studies by Brandt the alloy stream with lower speed widens after entrance into the die cavity and touches walls of the die cavity [1].

Kopf proved that both frommer and brandt theory are correct. If the kinetic energy in injection gate is greater than the die cavity resistance to molten metal flow, then die filling will be based on Frommer theory. Also, if the kinetic energy in injection gate is lesser than the die cavity resistance to molten metal flow then die filling will be based on brandt theory [2]. In 1991 the thermal field simulation in die casting dies was developed by computer software. This software solves two-dimensional model of heat conduction in the die casting dies using boundary element method (BEM). In recent

Mehdi Modabberifar is with Mechanical Engineering Department, Faculty of Engineering, Arak University, Arak 3815688349, Iran (phone: +98-86-32625700; fax: +98-86-34173450; e-mail: m-modabberifar@araku.ac.ir).

Behrouz Raad was with Mechanic Department of Science and Research branch, Islamic Azad university, Arak, Iran (e-mail: behrouz.rad66@gmail.com).

Bahman Mirzakhani is with Metallurgy Engineering Department, Faculty of Engineering, Arak University, Arak 3815688349, Iran (phone: +98-86-32625820; fax: +98-86-34173450; e-mail: b-mirzakhani@araku.ac.ir).

years, by developing simulation software, it is possible to predict defects such as shrinkage porosities in casting parts [3]-[5].

In this paper, an industrial helical gearbox flange (size ISO 50) die casting die is designed and die casting process is simulated. By using simulation results, die design is optimized and by using CAD / CAM technology, final die is produced.

II. DESIGN OF HELICAL GEARBOX FLANGE DIE CASTING DIE

There are many design issues that must be considered in the design of the dies. Firstly, the main die cavity must be same as the flange and allows the molten metal to flow easily into all of the cavities. Equally important is the removal of the solidified casting from the die, so a draft angle must be applied to the walls of the part cavity. In addition, other factors such as molten metal flow rate and pressure, solidification shrinkage, size and location of overflows and feeding system should be considered. On the other hand the location of the main cavity depends on parting line.

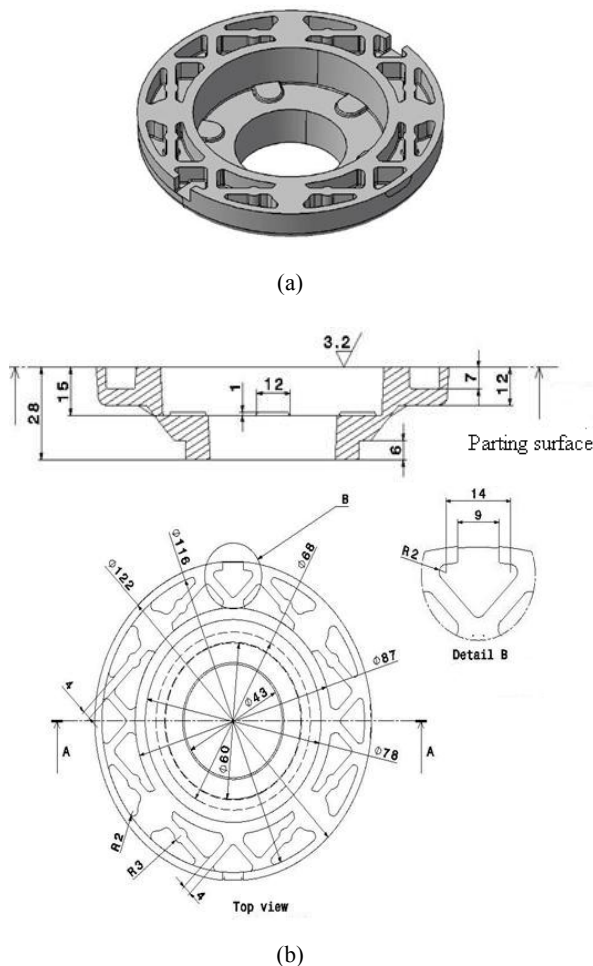

Fig. 2 (a) Model and (b) dimensions of the helical gearbox flange (all dimensions are in mm)

The first step for designing the die is computer modeling of the flange. Fig. 2 shows a three-dimensional model and dimensions of the flange. Next step is defining parting surface

which separates two halves of the die (core and cavity). Parting surface has a direct effect on material flow and die filling. The best parting surface for helical gearbox flange is flat type (Fig. 2). Walls draft angle was selected 1 degree. The amount of over size for compensating solidification shrinkage was selected 0.006 mm/m based on the selected material (here ALSI9CU3).

Cavity half die is the main part of the die and included runner, injection nozzle, feeder channels and gate. Sectional area of injection nozzle can be calculated with the following equation:

$$s_a = \frac{Q}{r_a} \quad (1)$$

In this equation, Q is flow (m³/s) and r_a is flow velocity (m/s). Injection time depends on the thinnest flange wall and material and for wall thickness of 10 mm; range of injection time is between 0.65 to 0.8 seconds. The injection time for filling die cavity can be written as:

$$t = \left(\frac{v}{s_a}\right)v_a \quad (2)$$

In this equation, t is the injection time (s), s_a is cross-sectional area of gate (m²) and v is the volume of flange (m³). v_a is flow velocity in injection nozzle and can be calculated using following equation:

$$v_a = \sqrt{\frac{2p}{\rho}} \quad (3)$$

where p and ρ are injection pressure (pa) and density of the metal (kg/ m²). Injection pressure is determined based on injection machine (here Model 08). Molten metal flow velocity is selected 25 (m/s) based on experience and the average thickness of the casting part. In addition, the cross-sectional area of the injection nozzle is 15.5 (mm²).

Finally, based on the above calculations, the core and cavity were modeled which are shown Fig. 3.

III. SIMULATION AND ANALYSIS OF HELICAL GEARBOX FLANGE CASTING PROCESS

In order to analyze the process of die casting, ProCAST was used. To do this, firstly, the die was modeled in CATIA software, then the model data files imported to ProCAST and die casting process was simulated. At first stage of the simulation, all die parts including the runner, feeding system overflows, and so on were meshed and then boundary conditions were applied to the meshed model.

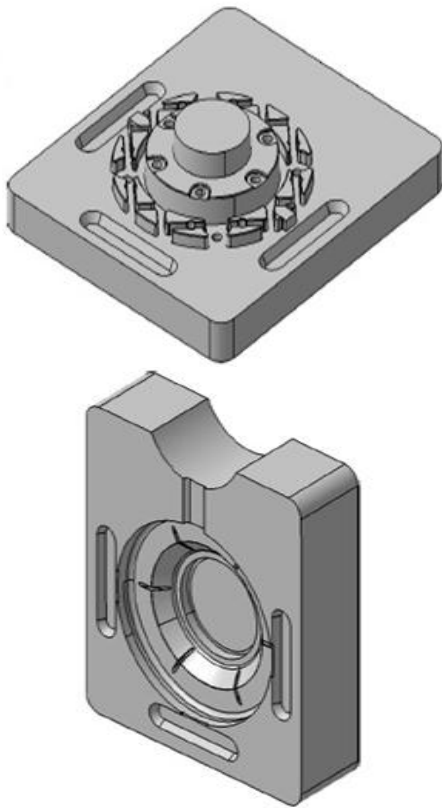

Fig. 3 Model of core and cavity

Fig. 4 shows the meshed model with boundary conditions. As the die casting die shape is same as the shape of the flange (with considering design considerations such as contraction and draft angle etc.), in simulation of die casting process, the most important variables are runner and feeding systems. Proper design of these parts reduces costs and improves the quality of casting parts. In this study, injection pressure and temperature are 20 Mpa and 700°C respectively. Also, the ambient temperature and preheating temperature of the die are 20° and 300°C respectively.

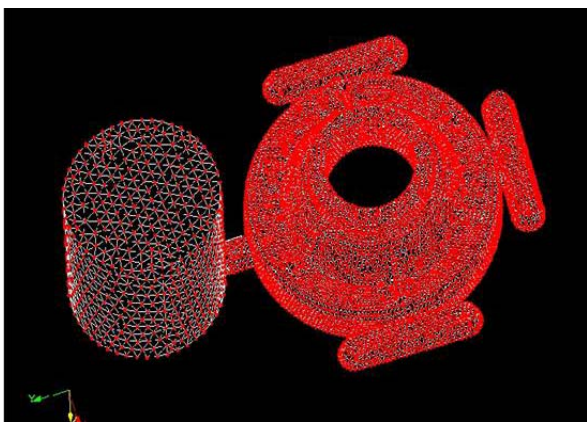

Fig. 4 Meshed model with boundary conditions

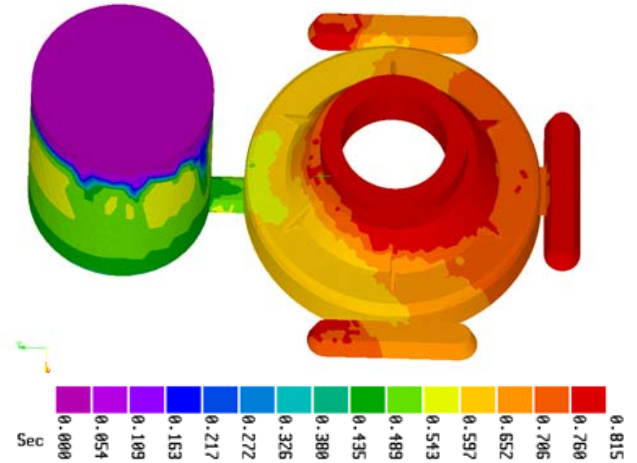

Fig. 5 Contour of filling time of the die cavity

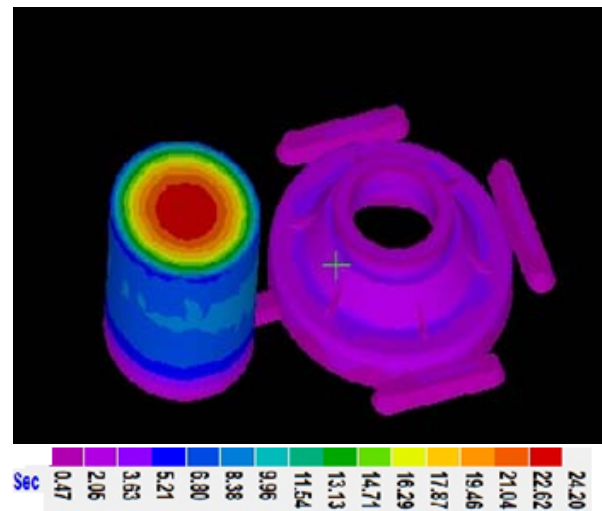

Fig. 6 Contour of solidification time

Based on the type of injection machine (Model 08), radius of gate and injection pressure was chosen.

Fig. 5 illustrates the Contour of filling time of the die cavity, the total time of filling and the filling procedure in different parts of the die. This figure shows that this die is filled in less than 1 second.

Fig. 6 shows the contour of solidification time. As can be seen in this figure, the total solidification time is 24 second and runner is the last solidified point.

Fig. 7 depicts the contour of temperature distribution 7.31 seconds after injection. By using this contour at different times, it is possible to determine the best time for ejecting the flange.

Another important parameter is flow lines during filling of the die. In this stage of design, the feeder channel and injection nozzle should be designed to reduce the possibility of turbulence in molten metal flow.

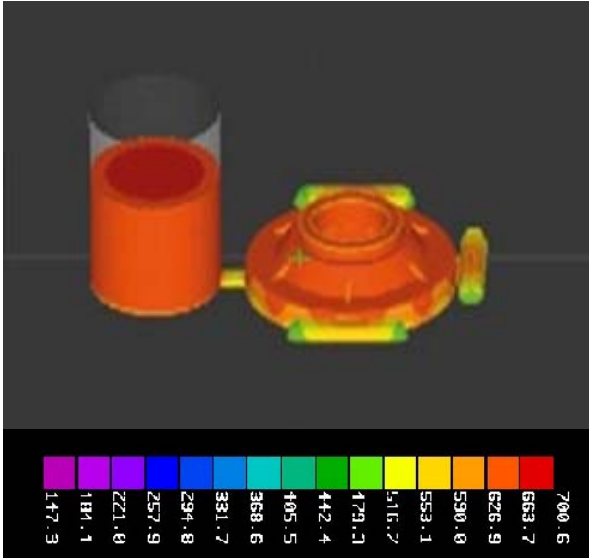

Fig. 7 Contour of temperature distribution 7.31 seconds after injection

Turbulence in molten metal flow increases the gas porosities in the flange. The effect of changing injection pressure, gate radius, and area of feeder channel on flow lines investigated in this die and it was found that by reducing pressure inside the die and injection nozzle radius, the mechanical strength of the part decreases. Fig. 8 shows the flow lines in injection pressure of 15 MPa, feeder channel

cross-sectional area of 225 mm², injection nozzle cross-sectional area of 13.5 mm² and the gate radius of 22.5 mm.

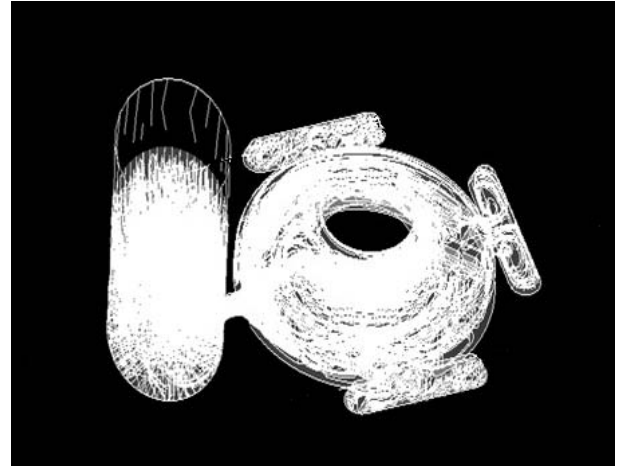

Fig. 8 Flow lines in die cavity

Another important parameter in designing the die is shrinkage porosities. The main factors affecting the shrinkage porosity are injection pressure, feeder channel cross-sectional area, injection nozzle cross-sectional area, gate radius and overflows cross section. Here, by considering different scenarios (based on experience) for these parameters, the lowest number of shrinkage porosity is obtained. Selected conditions have been shown in Table I.

TABLE I
 SELECTED CONDITIONS FOR INVESTIGATING THE EFFECT OF VARIOUS PARAMETERS ON THE NUMBER OF SHRINKAGE POROSITY IN FINAL PART

6 th Conditions	5 th Conditions	4 th Conditions	3 rd Conditions	2 nd Conditions	1 st Conditions	Parameter
20	20	20	15	20	15	injection pressure (MPa)
459	459	459	459	225	225	feeder channel cross-sectional area(mm ²)
15.3	15.3	15.3	15.3	13.5	13.5	injection nozzle cross-sectional area (mm ²)
37.5	37.5	37.5	22.5	37.5	22.5	gate radius (mm)
135	1200	412.5	412.5	412.5	412.5	overflow cross-sectional area(mm ²)

Figs. 9 (a)-(d) illustrate shrinkage porosities within the part in the first to fourth condition. These figures show that the fourth state has fewer holes than the other scenarios. In addition, the depths of the cavities in the first and second condition are more than other states. (In Figs. 9 depth of cavities decreases from green to blue and then violet)

After reaching the best condition for gate radius, feeder channel cross-sectional area, injection nozzle cross-sectional area and injection pressure in the die, the effect of overflows size (scenarios V and VI) on shrinkage porosity was investigated. The results were shown in Figs. 10 (a), (b).

As shown in Fig. 10 (a) it can be seen that by increasing overflows size compared to 4 previous conditions, there are no significant changes in the rate of shrinkage porosities, but the change causes more raw material and thereby increases the cost of process. Fig. 10 (b) shows that by reducing the overflow size, shrinkage porosities dramatically increases and thus the final part will reject.

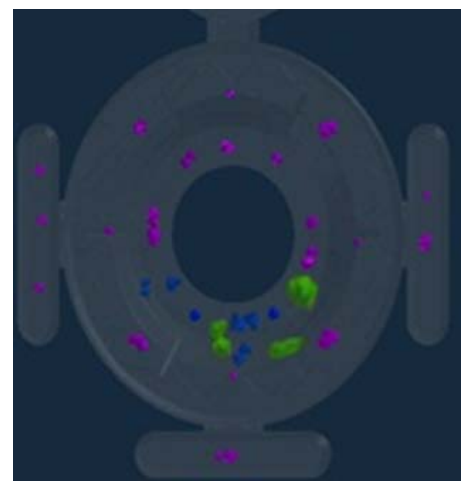

(a)



(b)

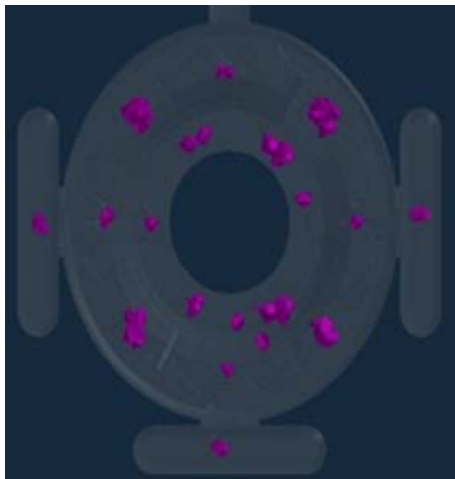

(c)



(d)

Fig. 9 (a)-(d) Shrinkage porosity in the part for conditions 1-4 in Table I respectively

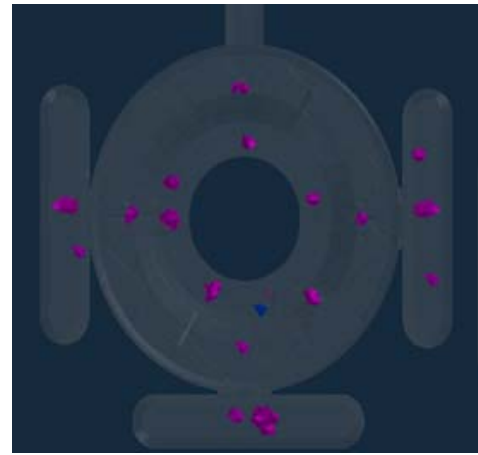

(a)

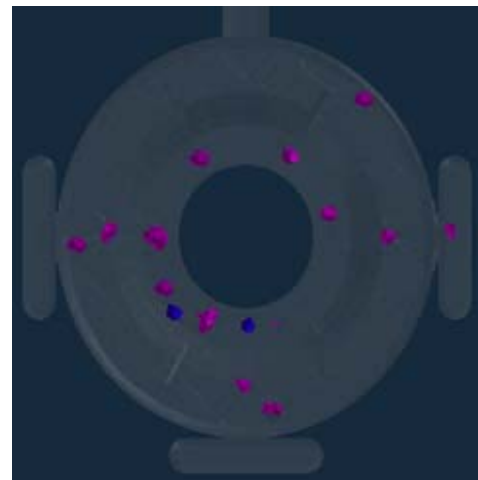

(b)

Fig. 10 (a), (b) Shrinkage porosity in the part for conditions 5 and 6 in Table I respectively

IV. MANUFACTURING HELICAL GEARBOX FLANGE DIE

By finalization of the die dimensions from simulation results, the die was built using CAD/CAM technology. Die was built from steel (H13) X40 CrMov51 and also got hardened. Core and cavity were machined using CNC machined and other parts machined by universal machine tools. Figs. 11 (a)-(c) show the core (top), cavity (middle) and the final part (bottom).

REFERENCES

- [1] E. Brunhuber, *Moderne Druckgussfertigung*, Berlin. Fachverlag Schiele & Schon GMBH, 1963.
- [2] G. Bar-Meir, *Fundamentals of Die Casting Design*, Potto Project, 1999.
- [3] H. Yan, W. Zhuang, Y. Hu, Q. Zhang, H. Jin, *Numerical simulation of AZ91D alloy automobile plug in pressure die casting process*, Journal of Materials Processing Technology, Volumes 187–188, Pages 349–353, 2007.
- [4] K. Domkin, J.H. Hattel, J. Thorborg, *Modeling of high temperature- and diffusion-controlled die soldering in aluminum high pressure die casting*, Journal of Materials Processing Technology, Volumes 209, Pages 4051–4061, 2009.
- [5] B.H. Hu, K.K. Tong, X.P. Niu, I. Pinwill, *Design and optimisation of runner and gating systems for the die casting of thin-walled magnesium telecommunication parts through numerical simulation*, Journal of Materials Processing Technology, Volumes 105, Pages 128–133, 2000.



(a)



(b)



(c)

Fig. 11 (a), (b) Manufactured die and (c) the final part

V. CONCLUSION

In this paper, design, process simulation and production of an industrial helical gearbox flange die casting die were presented. The simulation results showed that by increasing molten metal injection pressure and decreasing Injection nozzle cross-sectional area the mechanical strength of final part increases. Also, by reducing overflows size, number of shrinkage porosity increases.