

Design and Implementation of a Control System for a Walking Robot with Color Sensing and Line Following Using PIC and ATMEL Microcontrollers

Ibraheem K. Ibraheem

Abstract—The aim of this research is to design and implement line-tracking mobile robot. The robot must follow a line drawn on the floor with different color, avoids hitting moving object like another moving robot or walking people and achieves color sensing. The control system reacts by controlling each of the motors to keep the tracking sensor over the middle of the line. Proximity sensors used to avoid hitting moving objects that may pass in front of the robot. The programs have been written using micro c instructions, then converted into PIC16F887 ATmega48/88/168 microcontrollers counterparts. Practical simulations show that the walking robot accurately achieves line following action and exactly recognizes the colors and avoids any obstacle in front of it.

Keywords—Color sensing, H-bridge, line following, mobile robot, PIC microcontroller, obstacle avoidance, phototransistor.

I. INTRODUCTION

THE field of robotics encompasses a broad spectrum of technologies in which computational intelligence is embedded in physical machines, creating systems with capabilities far exceeding the core components alone. Such robotic systems are then able to carry out tasks that are unachievable by conventional machines, or even by humans working with conventional tools. The ability of a machine to move by itself that is “autonomously” is one such capability that opens up an enormous range of applications that are uniquely suited to robotic systems. Robotic vehicles are machines that move “autonomously” on the ground, in the air, undersea, or in space. Such vehicles are “unmanned,” in the sense that no humans are on board. These vehicles move by themselves, under their own power, with sensors and computational resources onboard to guide their motion. However, such “unmanned” robotic vehicles usually integrate some form of human oversight or supervision of the motion and task execution. Robotic vehicles are capable of traveling where people cannot go or where the hazards of human presence are great [1].

While human exploration of Mars may someday be possible, it is clear that robotic exploration is a fundamental step that provides enormous scientific and technological rewards enhancing our knowledge of other planets. The National Aeronautics and Space Administration (NASA) Mars

rover is a robotic vehicle that has successfully achieved these goals, becoming a remote scientific laboratory for exploration of the Martian surface. The Mars rover is an example of a robotic vehicle under supervisory control from the earth, and capable of local autonomous operation for segments of motion and defined scientific tasks). Another example of a hostile and hazardous environment where robotic vehicles are essential tools of work and exploration is the undersea world. In addition to space and oceans, there are many applications where human presence is hazardous. Nuclear and biological contamination sites must often be explored and mapped to determine the types and extent of Contamination, and provide the basis for remediation. Military operations incorporate many different autonomous and remotely operated technologies for air, sea, and ground vehicles [2]. The problem of robotic control has been reported by so many researchers in literature, in [3] authors suggests effective visual tracking system for moving objects with specified color and motion information, while [4] Designed a Low-cost Autonomous Mobile Robot using image processing and IR sensor circuits. Autonomous Mobile Robots with On-Board Vision and Local Intelligence has been investigated by [5]; they developed their own controllers with a variety of digital/analog I/O facilities and their own operating system RoBIOS, which allows maximum flexibility. The design of an obstacle avoidance robot has been studied and implemented in [6]-[9], while researchers in [10] described the integration of laser-based perception, footstep planning, and walking control of a humanoid robot for navigation over previously unknown rough terrain. [11] Introduced algorithms that enable a robot to devise its own curriculum; and recognize when the lighting conditions have changed sufficiently to warrant learning a new color map. A visually guided swimming robot has been designed in [12], whereas [13] presented the design of a four-legged walking robot using neural networks. A Quadruped walking robot with multi PIC microcomputer system has been designed by authors in [14]. The researchers in [15] designed an effective visual tracking system for moving objects with specified color and motion information.

II. PIC AND ATMEL MICROCONTROLLERS

A. PIC Microcontroller

The PIC16F887 is a well-known product by Microchip (Fig. 1). It features all the components which modern

This work was supported by Baghdad University.

Ibraheem K. Ibraheem is with the Department of Electrical Engineering /Engineering College / Baghdad University, Al-Risafa, Al-Jadriyah, Iraq, (phone: 009647702562658; e-mail: ibraheem151@gmail.com).

microcontrollers normally have. For its low price, wide range of application, high quality and easy availability, it is an ideal solution in applications such as the control of different processes in industry, machine control devices, measurement of different values etc. Some of its main features (see Fig. 2) are [16]:

- RISC architecture: Only 35 instructions to learn, all single-cycle instructions except branches.
- Operating frequency 0-20 MHz.s
- Precision internal oscillator: Factory calibrated, Software selectable frequency range of 8MHz to 31 KHz.
- Power supply voltage 2.0-5.5V: Consumption: 220uA (2.0V, 4MHz), 11uA (2.0 V, 32 KHz) 50nA (stand-by mode).
- Power-Saving Sleep Mode.
- Brown-out Reset (BOR) with software control option.
- 35 input/output pins: High current source/sink for direct LED drive, software and individually programmable *pull-up* resistor, Interrupt-on-Change pin.
- 8K ROM memory in FLASH technology: Chip can be reprogrammed up to 100.000 times.
- 256 bytes EEPROM memory: Data can be written more than 1.000.000 times.
- 368 bytes RAM memory.
- A/D converter 14-channels, 10-bit resolution.
- 3 independent timers/counters.
- Watch-dog timer.
- Analogue comparator module with two analogue comparators, fixed voltage reference (0.6V), Programmable on-chip voltage reference.
- PWM output steering control.
- Enhanced USART module.
- Supports RS-485, RS-232 and LIN2.0, Auto-Baud Detect.
- Master Synchronous Serial Port (MSSP): supports SPI and I2C mode.
- In-Circuit Serial Programming Option: Chip can be programmed even embedded in the target device.

B. ATMEGA 168 Microcontroller

The Atmel ATmega48/88/168 microcontroller is a low-power CMOS 8-bit microcontroller based on the AVR enhanced RISC architecture (Fig. 3). By executing powerful instructions in a single clock cycle, the ATmega48/88/168 achieves throughputs approaching 1 MIPS per MHz allowing the system designer to optimize power consumption versus processing speed. The AVR core combines a rich instruction set with 32 general purpose working registers. All the 32 registers are directly connected to the Arithmetic Logic Unit (ALU), allowing two independent registers to be accessed in one single instruction executed in one clock cycle. The features of the ATmega48/88/168 microcontroller are (see Fig. 4) [17]:

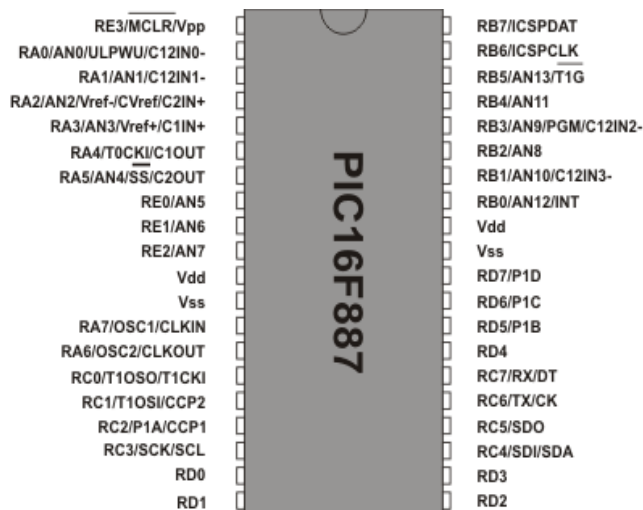

Fig. 1 PIC16F887 PDIP 40 Microcontroller

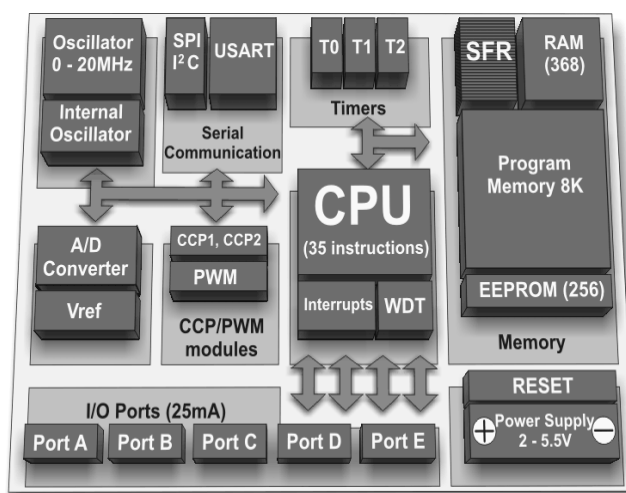

Fig. 2 PIC16F887 Microcontroller block diagram

- High performance, low power Atmel AVR 8-bit microcontroller
- Advanced RISC architecture
 - 131 powerful instructions – most single clock cycle execution.
 - 32 × 8 general purpose working registers.
 - Fully static operation
 - Up to 20 MIPS throughput at 20MHz
 - On-chip 2-cycle multiplier
- High endurance non-volatile memory segments
 - 4/8/16 Kbytes of in-system self-programmable flash program memory
 - 256/512/512 bytes EEPROM
 - 512/1K/1Kbytes internal SRAM
 - Write/erase cycles: 10,000 flash/100,000 EEPROM
 - Data retention: 20 years at 85°C/100 years at 25°C.
 - Optional boot code section with independent lock bits
- * In-system programming by on-chip boot program.
- * True read-while-write operation.

- Programming lock for software security
- QTouch library support
- Capacitive touch buttons, sliders and wheels
- QTouch and QMatrix acquisition
- Up to 64 sense channels
- Peripheral features
- Two 8-bit timer/counters with separate prescaler and compare mode
- One 16-bit timer/counter with separate prescaler, compare mode, and capture mode
- Real time counter with separate oscillator
- Six PWM channels
- 8-channel 10-bit ADC in TQFP and QFN/MLF package
- 6-channel 10-bit ADC in PDIP Package
- Programmable serial USART
- Master/slave SPI serial interface
- Byte-oriented 2-wire serial interface (Philips I2C compatible)
- Programmable watchdog timer with separate on-chip oscillator
- On-chip analog comparator
- Interrupt and wake-up on pin change
- Special microcontroller features
- Debug WIRE on-chip debug system
- Power-on reset and programmable brown-out detection
- Internal calibrated oscillator
- External and internal interrupt sources
- Five sleep modes: Idle, ADC noise reduction, power-save, power-down, and standby.

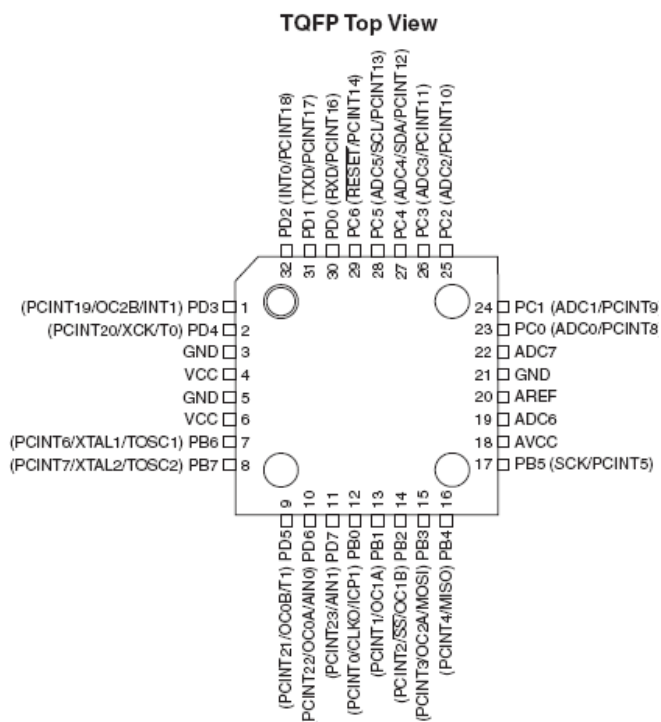

Fig. 3 ATmega48/88/168 Microcontroller

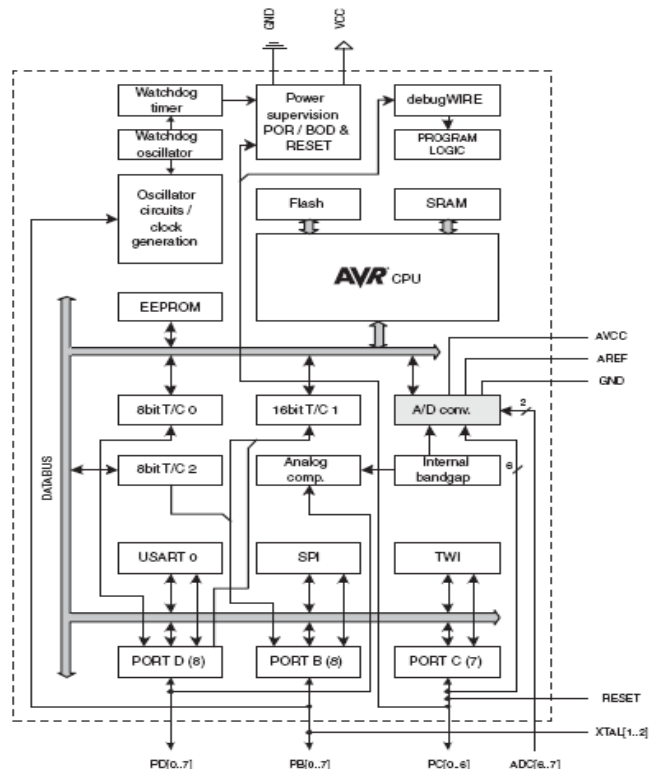

Fig. 4 Block diagram of the ATmega48/88/168 Microcontroller

- I/O and packages
- 23 programmable I/O lines
- 28-pin PDIP, 32-lead TQFP, 28-pad QFN/MLF and 32-pad QFN/MLF
- Operating voltage
- 1.8V - 5.5V for Atmel ATmega48V/88V/168V
- 2.7V - 5.5V for Atmel ATmega48/88/168.
- Temperature range
- -40°C to 85°C
- Speed grade
- ATmega48V/88V/168V: 0 - 4MHz @ 1.8V - 5.5V, 0 - 10MHz @ 2.7V - 5.5V
- ATmega48/88/168: 0 - 10MHz @ 2.7V - 5.5V, 0 - 20MHz @ 4.5V - 5.5V
- Low power consumption
- Active mode: 250µA at 1MHz, 1.8V, 15µA at 32 KHz, 1.8V (including oscillator)
- Power-down mode: 0.1µA at 1.8V

III. CONTROL SYSTEMS DESIGN FOR WALKING ROBOT

Three control units have been designed for the walking robot, these are:

A. DC Motor Driving Using H-Bridge

An H bridge is an electronic circuit that enables a voltage to be applied across a load in either direction. These circuits are often used in robotics and other applications to allow DC motors to run forwards and backwards. In the robot implementation two H-Bridges are used; one for each side to

control both motors for that side. An H bridge is built with four switches (solid-state or mechanical). When the switches S1 and S4 (according to Fig. 5) are closed (and S2 and S3 are open) a positive voltage will be applied across the motor. By Opening S1 and S4 switches and closing S2 and S3 switches, this voltage is reversed, allowing reverse operation of the motor. The switches S1 and S2 should never be closed at the same time, as this would cause a short circuit on the input voltage source. The same applies to the switches S3 and S4. This condition is known as shoot-through. The operation of the H-Bridge can be described as:

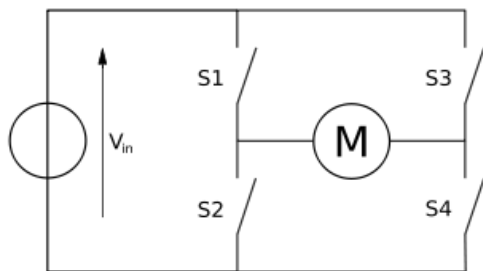

Fig. 5 H-Bridge diagram for the dc motor driving

The H-bridge arrangement is generally used to reverse the polarity of the motor, but can also be used to 'brake' the motor, where the motor comes to a sudden stop, as the motor's terminals are shorted, or to let the motor 'free run' to a stop, as the motor is effectively disconnected from the circuit. Fig. 6 summarizes the operation, with S1-S4 corresponding to the diagram above.

S1	S2	S3	S4	Result
1	0	0	1	Motor moves right
0	1	1	0	Motor moves left
0	0	0	0	Motor free runs
0	1	0	1	Motor brakes
1	0	1	0	Motor brakes

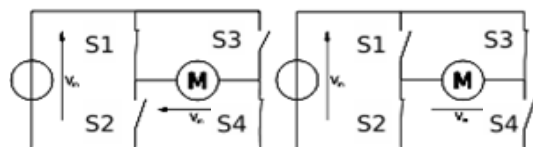

Fig. 6 The two basic states of an H-bridge

A solid-state H bridge is typically constructed using opposite polarity devices, such as PNP BJTs or P-channel MOSFETs connected to the high voltage bus and NPN BJTs or N-channel MOSFETs connected to the low voltage bus. So to operate a MOSFET, we applied a voltage to the gate (from your microcontroller), and suddenly a current of electrons passes through the other two pins. Connect a motor (M) in line

with one of the pins and your robot is set to go. In the schematic shown in Fig. 7 you will notice the letters A and B. These are your two control lines which you apply this logic voltage to. Since you have two pins, and only a binary control, there are four possible things that can happen.

- * A=0 B=0: Nothing happens, the motor is turned off.
- * A=1 B=0: Motor rotates clockwise.
- * A=0 B=1: Motor rotates counterclockwise.
- * A=1 B=1: Your circuit explodes into pretty sparks.

The motion of the four motors of the walking robot is entirely controlled via PWM speed control, when we send a square wave at a certain frequency to control the MOSFET as shown above. Basically you are telling your controller to turn on and off the motor at very high rates. So through inductance the motor is neither fully on or fully off, but somewhere in between. Such as at a slower speed. Also a note that motor torque, under PWM, remains the same whether fully on or only a percentage on. However, varying voltage for speed control reduces torque. So with PWM you have maximum torque yet slower speeds. we will have to experiment with wave length for both on and off periods, as well as frequency, to optimize your speed control. But a guess usually works.

B. Color Sensor control Circuit Design

The main objective of this sub-control unit is to force the walking robot to step at certain color (see Fig. 8); this is achieved with the use of **CDS photo Resistors – PGM 5526**. Its series specification provides the mechanical data, electronic characteristic and test condition in terms of 5mm, 12mm, and 20mm. Token CDS resistors can be costumed designs and tighter tolerance available on request. The features of CDS photo Resistors – PGM are Epoxy or hermetical package, Reliable Performance, Quick Response, and Good Characteristic of spectrum.

The algorithm to Check Color can be explained in the following, the aim of color sensor to check the color of each station, since each station is determined by specific color. Once the robot stopped at any station, it gave an indication to the **PIC16F887** to begin test on the station's color as following:

- 1) The **PIC16F887** turned on each LED (red, green, and blue) in sequence each for **100ms**.
- 2) Each time turned the LED on the analog channel (**A2**) read the variable resistance voltage.
- 3) After taking the three readings, the PIC compares the readings taken and the lowest value of the voltage indicates that the color of that LED is the station's color as shown in Fig. 9.

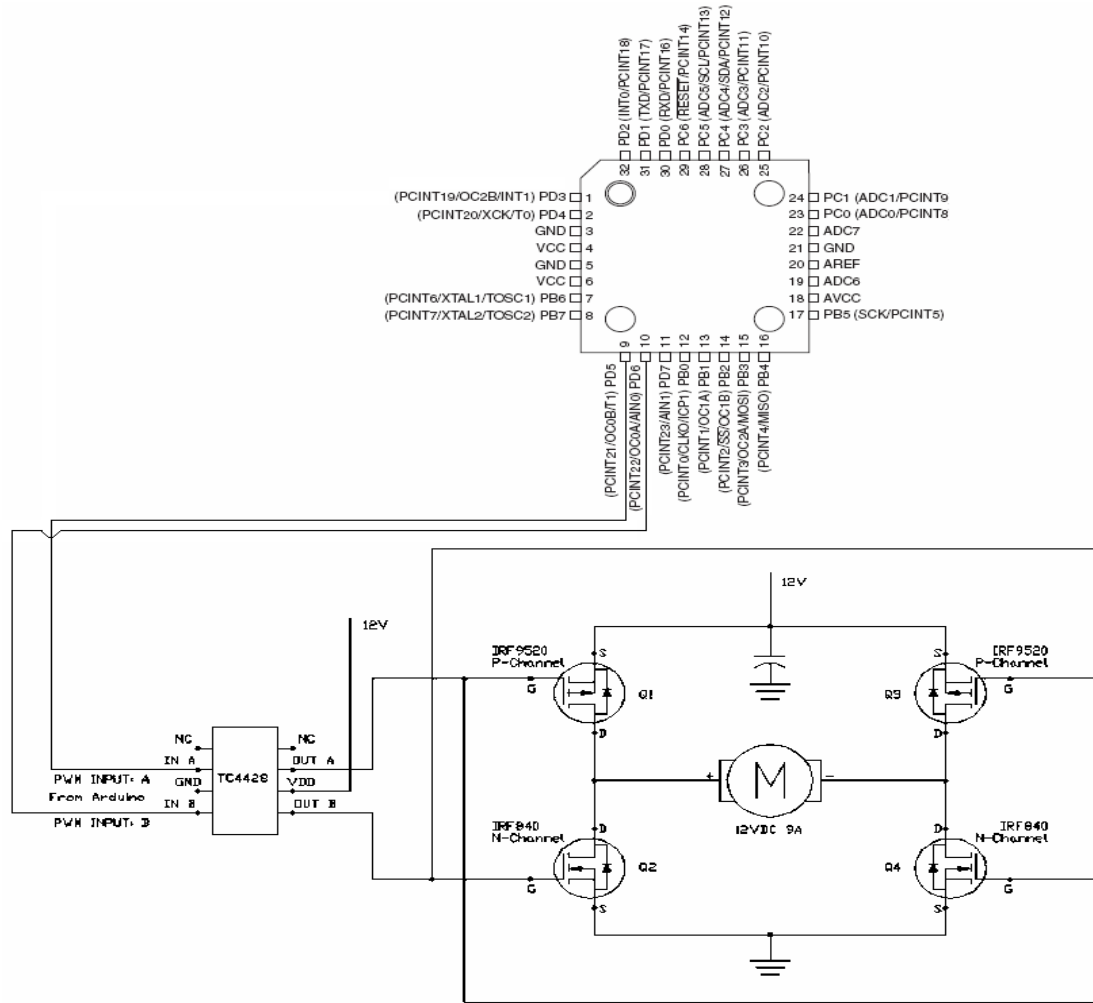

Fig. 7 H-Bridge diagram for the dc motor driving

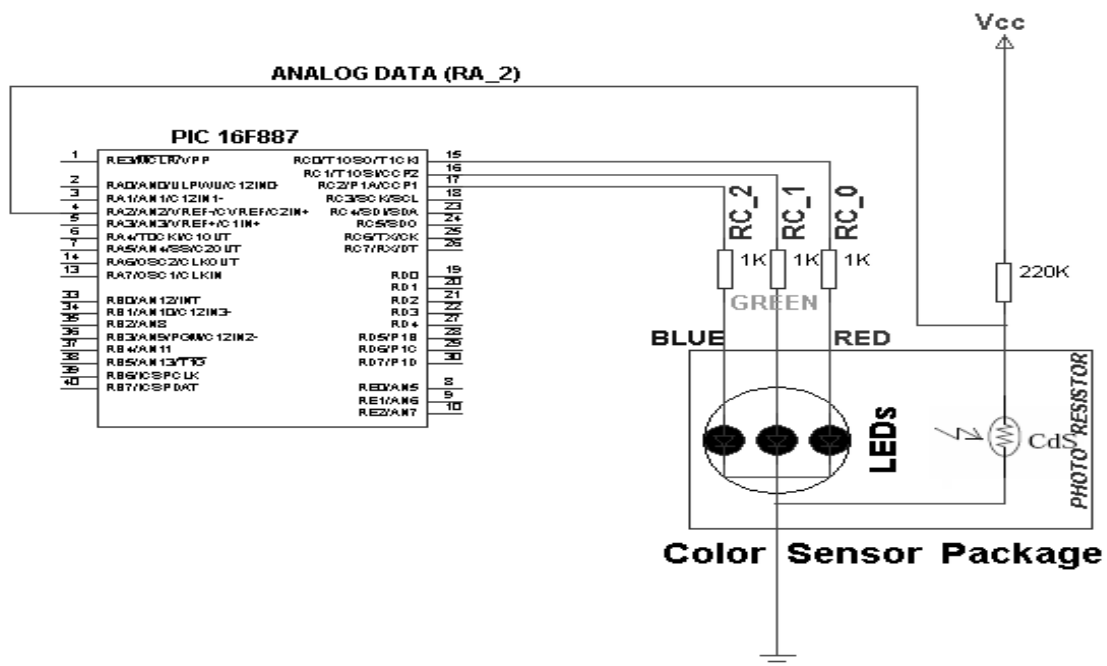

Fig. 8 Circuit and wiring diagram of the color-sensing unit

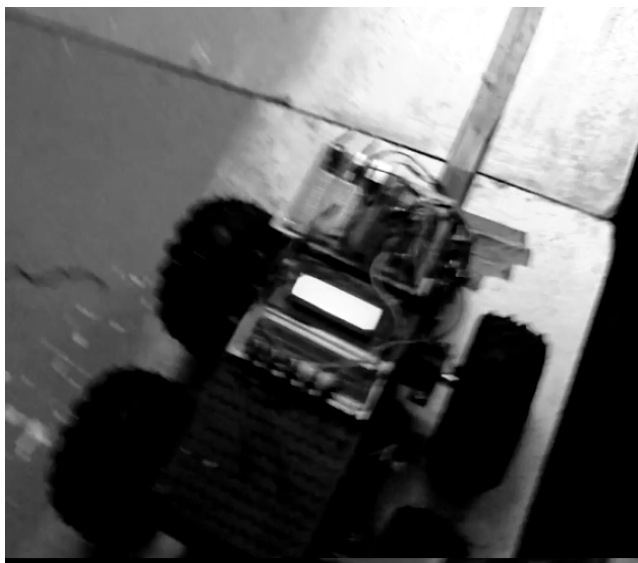

Fig. 9 Robot stopped at red station

C. Line Following Control Circuit Design

Within the implementation of this project five IR sensors have been used for tracking the line. Each of IR LED sends an IR all surfaces, except black ones, reflects the IR wave. If the surface is white, the IR receiver transistor receives the reflected wave and becomes on. This way the emitter-collector voltage becomes approximately zero. The output is taken from the emitter (emitter voltage) which should be approximately

equals DC source voltage. If the surface that the robot is walking over it is not white, the emitter voltage will be less than the DC source voltage until it reaches to zero at the black surfaces. The emitter voltage is then inputted to the comparator that compares with the reference voltage to convert it to the digital. So, when the color of the surface is black the output from comparator is zero volt (logic zero), else the comparator output is five volts (logic one). By this technique robot can recognize the route determined by black line. Fig. 10 depicts the circuit diagram of the line following sub-system. The components used in this unit are:

1. **IR333C-A 5mm IR LED:** EVERLIGHT's Infrared Emitting Diode (IR333C-A) is a high intensity diode, molded in a water clear plastic package. The device is spectrally matched with phototransistor, photodiode and infrared receiver Module.
2. **PT334-6B 5mm IR phototransistor:** PT334-6B is a high speed and high sensitive silicon NPN epitaxial planar phototransistor in a standard $\phi 5$ mm package. The package is an IR filter; spectrally match to infrared emitter diode.
3. **LM324 Amplifier:** The LM324 consist of four independent, high gains, internally frequency compensated operational amplifiers which were designed specifically to operate from a single power supply over a wide voltage range.

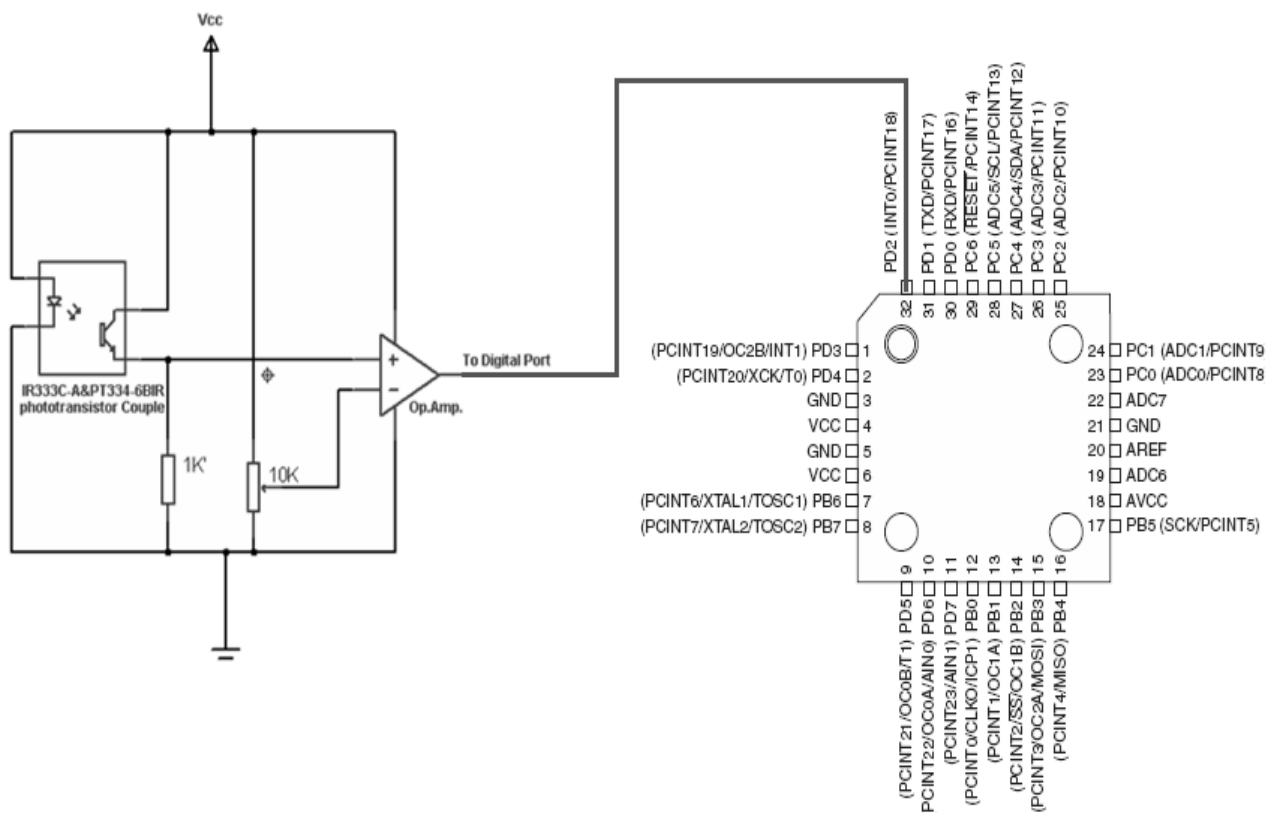

Fig. 10 The Line follower circuit diagram

D. Obstacle Avoidance Sub-System Design

We used MC005 the photoelectric sensor to detect an object. The MC005 can detect object in distance ranged between (0-80) cm. So, if an object exists, an IR wave sent from the transmitter will be reflected from object back to the receiver then the output will be taken from receiver transistor collector as shown in Fig. 11 becomes zero volt (logic zero). On contrary, if there is no object, no IR wave will be reflected back to the receiver, then the output will be one (five volts). The circuit diagram of the obstacle avoidance control unit is shown in Fig 12.

IV. RESULTS

The complete circuit diagram of the walking robot control system is shown in the Fig. 13; while Fig. 14 shows the hardware wiring implementation of the control system designed for this circuit. Concerning color sensing function, each station can be identifying by specific color or unique sequence of colors. Color sensor used to identify any station by detecting its color. So that, when the robot arrives to any one of station, the microcontroller ((PIC16F887)) performs testing on that station where as in case of that desired station.

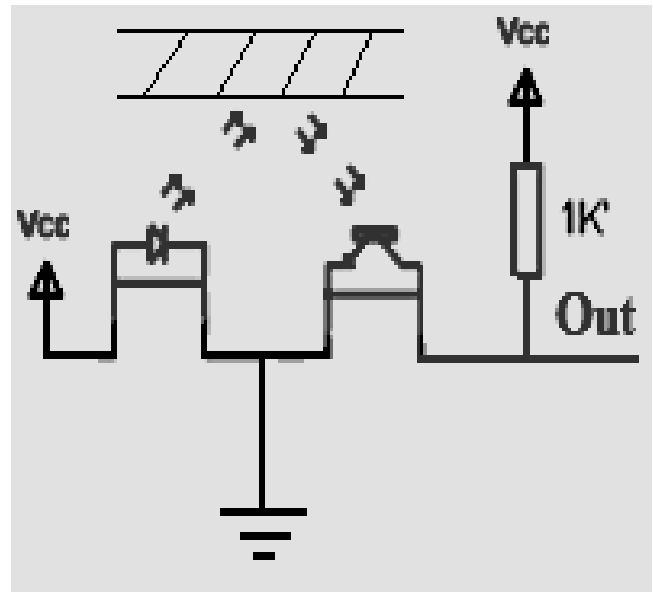

Fig. 11 Object detector electric circuit

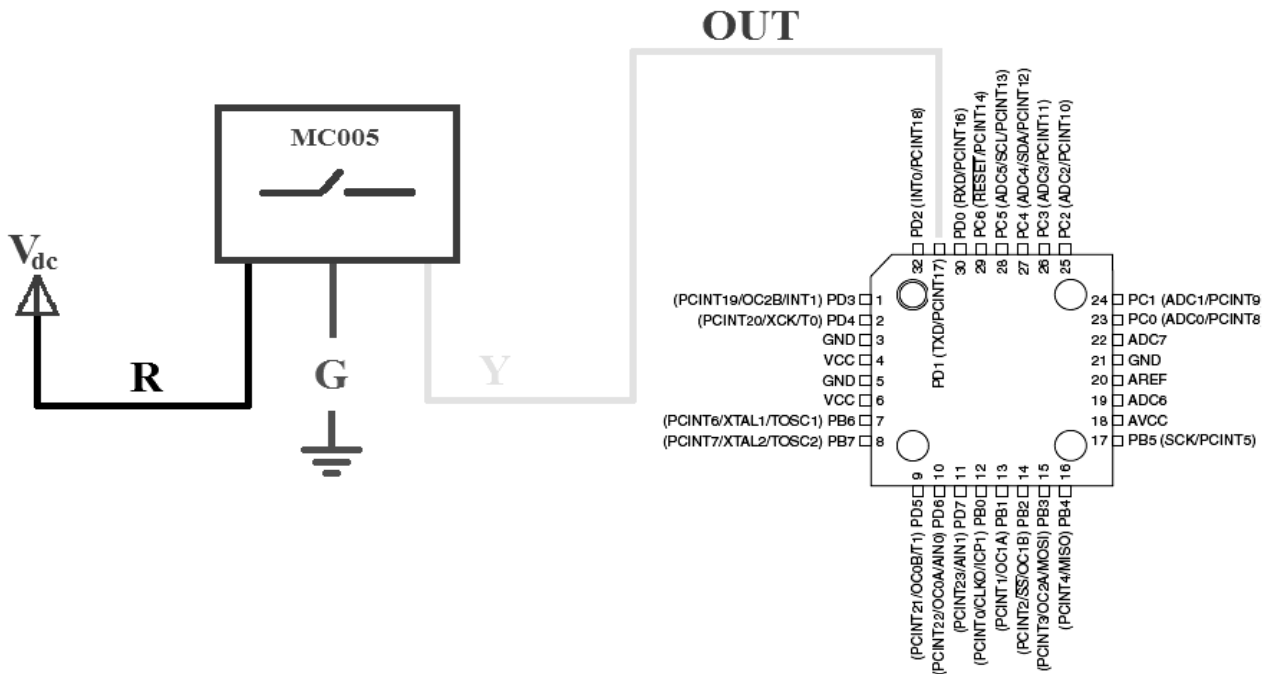

Fig. 12 Obstacle Avoidance Control Sub-System Unit

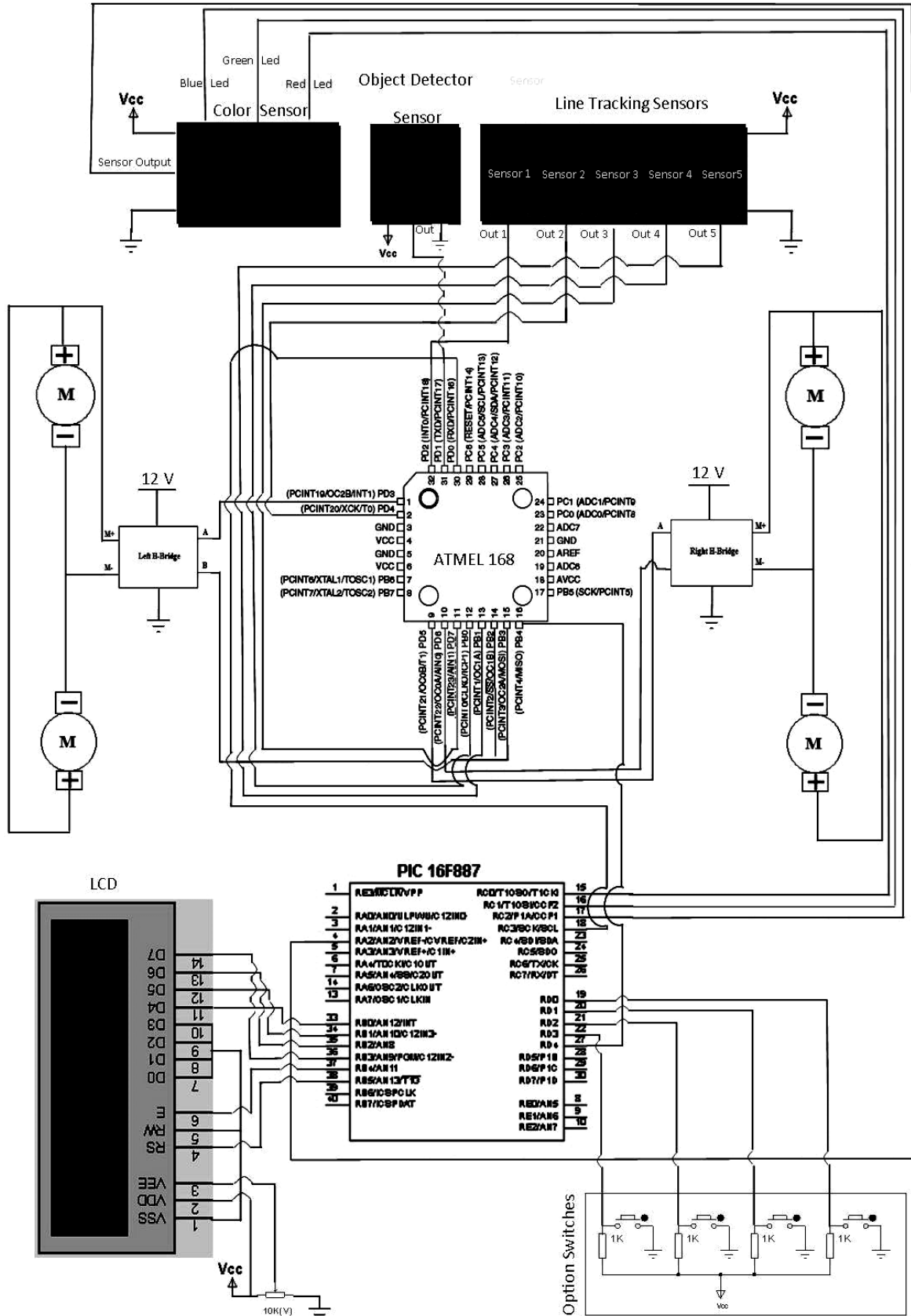

Fig. 13 Complete circuit diagram of the walking robot

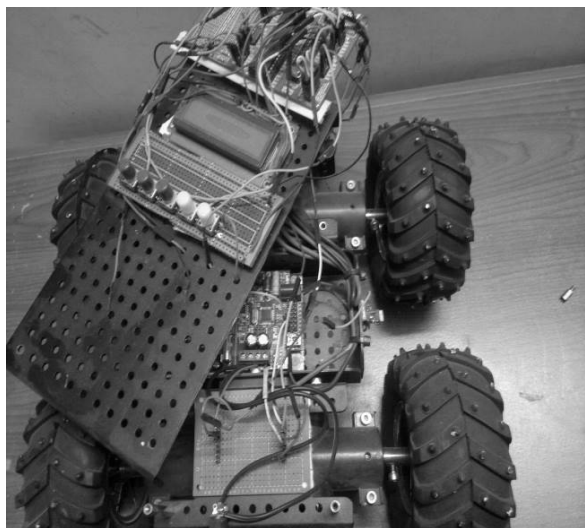

Fig. 14 H/W wiring implementation of the designed control system

The station is chosen by using the buttons attached on the walking robot (see Fig. 14) to identify the colored station that we want to stop at, each station has been given a number to mean a certain color, for example see Fig. 15. An indication of arrival is displayed on LCD when the walking robot arrives to that specific station as shown in Fig. 16.

Obstacle avoidance is satisfied in such a way when the robot moves on the line and detect any obstacle it stop until that obstacle move from the line. The robot can detect any obstacle using photo sensor connected to the microcontroller ((ATMEL 168)) and placed in front of the walking robot as shown in Fig. 17. In order to detect any obstacle, the microcontroller periodically checks the status of photo sensor to ensure that the route is clear.



Fig. 15 Choosing the station using colors

The line following function has been done by using sensors that arranged to be perpendicular on the line and each one form a deviation angle roughly by $(180/5)$ degrees, by reading the status of these sensors the controller forces the robot to stay on the line by controlling the motion of the motors, see Fig. 18.



Fig. 16 Station arrival indication

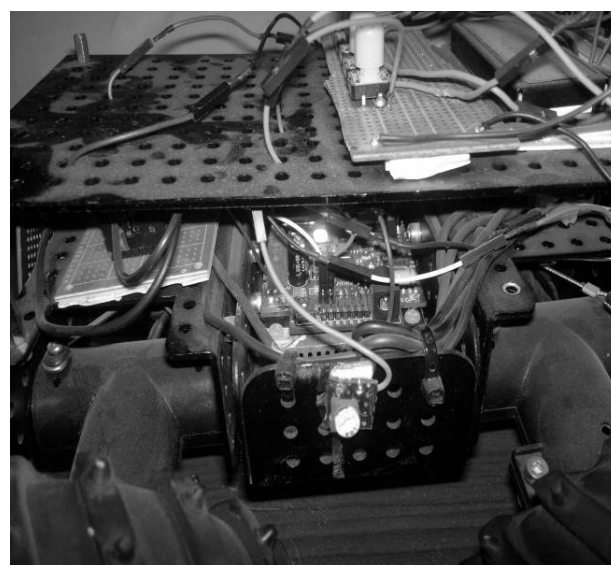

Fig. 17 Obstacle avoidance sensor

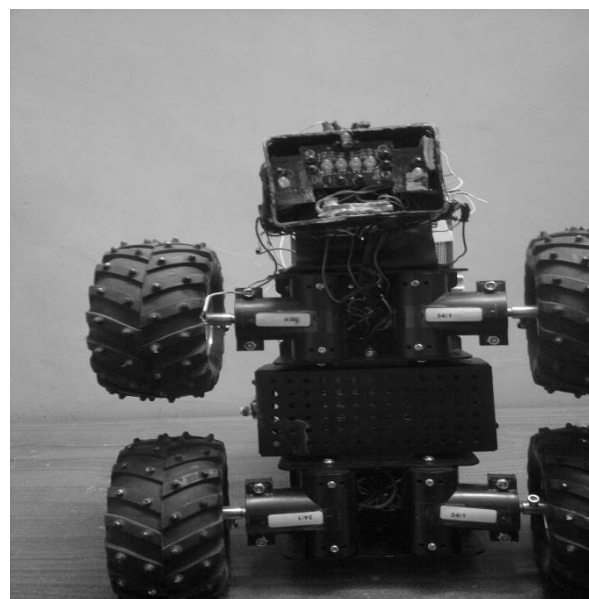

Fig. 18 The Line follower sensors

Finally, the operation of the complete system can be described as follows, PIC16F887 microcontroller represent the master that instruct ((ATMEL 168)) who read the status of the IR sensor that detect the line in order to remain the robot on the line until arrive to station. When the robot arrives to station, PIC16F887 signals to ATMEL 168 to stop the motion of the robot until complete the checking of this station. Therefore, if that station is the desired, an indication of arrival will be displayed on LCD, robot remains in that station until another request for other station is issued.

V. CONCLUSIONS

The system has been built with two microcontrollers; PIC is in charge of the intelligent functions proposed in this research, while the Atmel is responsible for the motion and the steering of the walking robot. It is found that good responses have been obtained with this configuration, the PIC responds so fast to the commands and the Atmel too just with one shortage that is the H-bridge circuit of the Atmel is very sensitive to high voltages where a high Dc voltage was required to turn On / Off the four motors. Because of the On /Off control to the motors, little fluctuations have been observed when the walking robot tries to stop at certain or during line following.

REFERENCES

- [1] B. Siciliano, L. Sciavicco, L. Villani, G. Oriolo, Robotics: Modelling, Planning, and Control. Springer, 2009.
- [2] R. R. Murphy. Introduction to AI Robotics. MIT Press, 2000.
- [3] S. Kim, S. Lee, S. Kim, and J. Lee, "Object Tracking of Mobile Robot using Moving Color and Shape Information for the aged walking," International Journal of Advanced Science and Technology, Vol. 3, February, 2009.
- [4] K. K. Jinasena and R. N. Meegama, "Autonomous Mobile Robots with On-Board Vision and Local Intelligence," International Journal of Robotics and Automation, (IJRA), Vol. 2, Issue 1, 2011.
- [5] T. Bräunl and B. Graf, "Design of a Low-cost Autonomous Mobile Robot," Proc. 2nd IEEE Workshop on Perception for Mobile Agents, Fort Collins CO, pp 51-57, June 1999.
- [6] P. Kinsky and Q. Zhou, "Obstacle Avoidance Robot," Bachelor Project Report, Worcester Polytechnic Institute, 2008.
- [7] G. Freitas, B. Hamner, M. Bergerman, and S. Singh, "A practical obstacle detection system for autonomous orchard vehicles," IEEE/RSJ International Conference on Intelligent Robots and Systems (IROS), pp. 3391 – 3398, 7-12 Oct. 2012.
- [8] Y. K. Cho, W. S. Lee, E. G. Kim, and S. H. Han, "A study on obstacle avoidance for stable walking of biped robots Control," 11th International Conference on Automation and Systems (ICCAS), pp 1104-1105, 26-29 Oct. 2011.
- [9] Y. Huang, C. Wu, ; C. Ko ; K. Young , "Collision-free guidance for passive robot walking helper," IEEE International Conference on Systems, Man, and Cybernetics (SMC), pp. 3129 – 3134, 14-17 Oct. 2012.
- [10] K. Nishiwaki, J. Chestnutt, and S. Kagami, "Autonomous Navigation of a Humanoid Robot over Unknown Rough Terrain using a Laser Range sensor," The International Journal of Robotics Research, 17 August 2012.
- [11] M. Sridharan and P. Stone, "Color Learning on a Mobile Robot: Towards Full Autonomy under Changing Illumination," IJCAI, pp. 2212-2217, 2012.
- [12] Dudek, Gregory, et al. "A visually guided swimming robot," IEEE International Conference on Intelligent Robots and Systems (IROS), 2005.
- [13] S. Yldirim, "Four Legged Walking Robot Control using neural Networks," Journal of Scientific and Industrial research, vol. 65, pp. 887-893, Nov. 2006.
- [14] Y. Takahashi, M. Watanabe, and S., "Quadruped walking robot with multi PIC microcomputer system," International Conference on Control Automation and Systems (ICCAS), pp. 953 – 956, 27-30 Oct. 2010.
- [15] S. Kim, S. Lee, and S. Kim, ., "Object Tracking of Mobile Robot Using Moving Color and Shape Information for the Aged Walking," Second International Conference on Future Generation Communication and Networking, Vol. 2, pp. 293 – 297, 13-15 Oct. 2008.
- [16] M. Verle, PIC Microcontrollers. mikroElektronika; 1st edition 2008.
- [17] D. Wheat. Arduino Internals. Apress Academic, 30 Nov. 2011.