

Passenger Seat Vibration Control of Quarter Car System with MR Shock Absorber

Devdutt, M. L. Aggarwal

Abstract—Semi-active Fuzzy control of quarter car system having three degrees of freedom and assembled with magneto-rheological (MR) shock absorber is studied in present paper. First, experimental work was performed on an MR shock absorber under different excitation conditions to obtain force-displacement and force-velocity curves. Then, for the application of experimental data in semi-active quarter car system, a polynomial model was selected. Finally, Fuzzy logic controller was designed having the combination of Forward fuzzy controller and Inverse fuzzy controller for integration in secondary suspension system of concerned model. The proposed controlled quarter car model was compared with uncontrolled system using simulation work under bump type of road excitation. Results obtained by simulation work shows the effectiveness of fuzzy controlled suspension system in improving the ride comfort and safety of travelling passengers compared to uncontrolled suspension system.

Keywords—MR shock absorber, three degrees of freedom, quarter car model, fuzzy controller.

I. INTRODUCTION

SUSPENSION system has to fulfill conflicting multiple tasks related to passenger ride comfort, controlling the suspension deflection within designed limits as well as to enhance and provide road holding capability to travelling vehicles. Depending on the effectiveness and performance delivering behavior of the vehicle system, a suspension system can be categorized into three types generally known as passive or uncontrolled, semi-active and active. Normally, passive suspension system is assembled with uncontrollable shock absorber having no feedback control and represents cost-effective technology. However, optimum ride comfort and related requirements cannot be achieved in a desired way due to uncontrollable damping force generation nature of shock absorber thus limiting its performance within certain frequency range as well as under changing vehicle travelling conditions. While active suspension system technology can provide best results in a wider frequency range when the problems related to ride comfort, safety of vehicle and working of suspension system are considered due to assembly of mechatronics based devices such as sensors and actuators. Unfortunately, high cost of assembled parts and complex technology pose major hindrance in its wide spread

commercial adaptability. These drawbacks of passive and active suspension system technology forced the researchers and automotive industries to design and develop semi-active suspension system concept by investment of time and money. In recent decades, application of semi-active technology is increasing and widely accepted by various industries, manufacturing different devices based on this technology since it can provide better performance benefits compared to passive one and at very low cost compared to active one. Research efforts in the direction of semi-active suspension technology have given rise to the birth of controllable shock absorbers known as electro-rheological (ER) and magneto-rheological (MR) shock absorbers, making this technology practically feasible for engineering applications.

MR shock absorber based semi-active control technology has influenced various fields ranging from automotive sector, medical applications as well as civil structures, utilizing the MR devices for vibration mitigation purpose. Vehicles having semi-active control based on the MR shock absorber damping force generation capability is emerging area for research and development which laid down the foundation for further research and explored by many researchers [1]-[3]. The performance related to vibration parameters of semi-active systems is dependent on the selected and implemented control strategy. In past, researchers have studied different control strategies such as preview control [4], linear optimal control [5], sliding mode control [6], skyhook, groundhook and hybrid control [7], model-following sliding mode control [8], neuro-fuzzy control [9]-[10], gain scheduling control [11], H_∞ control [12]-[13], on-off sky-hook, continuous sky-hook, on-off balance, continuous and adaptive damping control [14], fuzzy logic control [15] and human-simulated intelligent control [16] for the development, testing, performance comparison and implementation of necessary mechatronics based devices using semi-active technology.

The crucial problem and challenging task for the effective and desired performance of MR shock absorber during working period is its hysteretic and nonlinear dynamic nature. Thus, to take full advantage in terms of real life applications of MR shock absorbers, proper understanding and modelling of its test results under various excitation conditions is very important. Various nonparametric and parametric models have been presented in literature after proper development and testing to adequately characterize and track the dynamic performance of MR shock absorbers. Nonparametric models include neuro-fuzzy model [17]-[19], polynomial model [20], black-box model [21]-[23], neural network model [24]-[26], Ridgenet model [27], fuzzy model [28] and query based model

Devdutt is research scholar in Mechanical Engineering Department, YMCA University of Science and Technology, Faridabad, Haryana, India (phone: 91-129-4198100, fax: 91-129-4198444, e-mail: devdutt.ymca@gmail.com).

Dr. M.L. Aggarwal is Professor in Mechanical Engineering Department, YMCA University of Science and Technology, Faridabad, Haryana, India. (email: aggarwalmlal@rediffmail.com).

[29] while parametric models represent the combination of certain mechanical devices and physical elements such as springs, coulomb friction and dashpots. The required parameters related to mentioned mechanical elements in the model are found out with the help of experimental results of MR shock absorber. Some of the useful parametric models are Bouc-Wen hysteresis model [30], Bingham model [31], phenomenological model [32], nonlinear hysteretic biviscous model [33], viscoelastic-plastic model [34], LuGre model [35], Dahl model [36] and hyperbolic tangent function-based model [37].

In present research, for tracing the experimental results of MR shock absorber, polynomial model is selected. Fuzzy logic control strategy is used in present paper for semi-active control of quarter car model having three degrees of freedom. For proper MR damping force generation and vibration control of suspension system, a combination of Forward and Inverse fuzzy controller is designed. The designed Forward fuzzy controller is responsible for generation of desired damping force signal whereas Inverse fuzzy controller generates current signal in output side which is supplied to assembled MR shock absorber for real time working. The effectiveness of the presented semi-active quarter car system in controlling the passenger seat vibrations taking into account is evaluated using simulation work in time domain while the vehicle travels over the bump type of input road profile. Simulation results are presented in graphical form and mathematical form which shows that the designed semi-active vehicle system with MR shock absorber provide much better performance in terms of passenger ride comfort and safety compared to uncontrolled or passive suspension system.

II. POLYNOMIAL MODELLING FOR MR SHOCK ABSORBER TEST RESULTS

MR shock absorber selected for testing purpose in present work is RD-1005-3, its technical characteristics can be found

in [38]. The supplied current to MR shock absorber coils is kept limited up to 1 A and increased from 0 A to 1 A with continuous increment of 0.25 A for safe and continuous working. To take the full advantage of MR shock absorber application in semi-active suspension system technology for vibration control purpose, testing work is necessary to know its damping force generation capability under various excitation conditions which was performed on MTS machine. The measured test results in terms of force-velocity curves while the excitation frequency is 0.5 Hz and displacement is ± 5 mm is given in Fig. 1 whereas the polynomial model fitted curves matching the dynamic behavior of tested MR shock absorber under test conditions are also shown in Fig. 1. On the other hand, calculated values of coefficients b_i and c_i are shown in Table I as obtained using polynomial model.

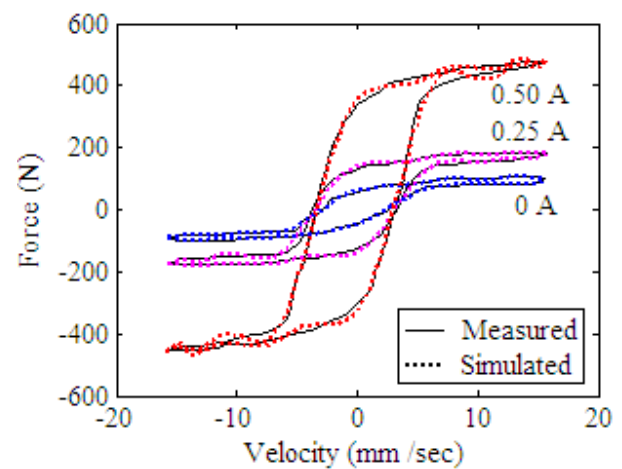

Fig. 1 Experimental and polynomial fitted curves (0.5 Hz, ± 5 mm): Force vs. Velocity

TABLE I
 CALCULATED COEFFICIENTS b_i AND c_i OF FITTED CURVE WITH VALUES

Positive acceleration				Negative acceleration			
Coefficients		Coefficients		Coefficients		Coefficients	
b_0	-28.75	c_0	-555.47	b_0	38.75	c_0	591.05
b_1	9.97	c_1	76.59	b_1	5.71	c_1	70.40
b_2	1.54	c_2	32.90	b_2	-2.00	c_2	-27.25
b_3	-0.03	c_3	2.41	b_3	0.26	c_3	2.37
b_4	-0.04	c_4	-0.72	b_4	0.05	c_4	0.47
b_5	-8.68E-04	c_5	-0.06	b_5	-0.01	c_5	-0.06
b_6	5.96E-04	c_6	7.65E-03	b_6	-5.93E-04	c_6	-3.72E-03
b_7	1.13E-05	c_7	5.48E-04	b_7	6.60E-05	c_7	4.75E-04
b_8	-3.99E-06	c_8	-4.29E-05	b_8	3.55E-06	c_8	1.37E-05
b_9	-4.97E-08	c_9	-2.11E-06	b_9	-2.66E-07	c_9	-1.75E-06
b_{10}	1.30E-08	c_{10}	1.21E-07	b_{10}	-1.03E-08	c_{10}	-2.08E-08
b_{11}	7.85E-11	c_{11}	2.94E-09	b_{11}	3.87E-10	c_{11}	2.38E-09
b_{12}	-1.61E-11	c_{12}	-1.36E-10	b_{12}	4.80E-12	c_{12}	1.17E-11

III. SEMI-ACTIVE QUARTER CAR MODEL

A quarter car model represents one-fourth body mass of the complete vehicle system taking only single wheel movement

into account. It is very helpful in evaluating the semi-active suspension performance for the purpose of implemented control system development. Fig. 2 shows the semi-active

quarter car system with three-degree-of-freedom (3 DOF) for comparative study of controlled suspension system having MR shock absorber and uncontrolled suspension system taking passenger ride into account.

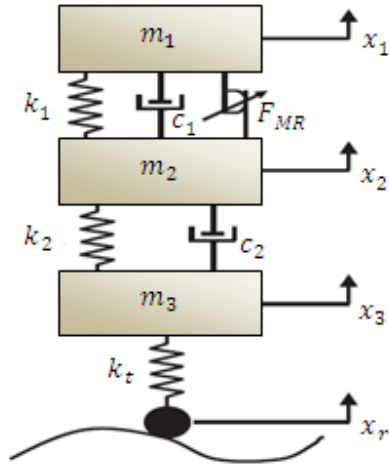

Fig. 2 Quarter car model with MR suspension

Following parameters are introduced into the designed model for study purpose as passenger mass, sprung mass and unsprung mass (m_1 , m_2 and m_3), primary suspension spring stiffness and damping coefficient (k_2 , c_2), secondary suspension spring stiffness and damping coefficient (k_1 , c_1) and single tire stiffness (k_t) respectively. The suspension system in the model performs as semi-active case when the MR shock absorber generated damping force (F_{MR}) can be controlled while in case of failure of control system i.e. when F_{MR} is zero, the system can still work in passive mode. Uncontrolled suspension system means that the primary and secondary suspension system of the quarter car system is integrated with traditional uncontrolled viscous shock absorber whereas controlled semi-active suspension denotes the assembly of MR shock absorbers in secondary suspension system.

The main interest of study in the designed model is the vertical dynamics of complete system without taking the roll and pitch dynamics into consideration. The governing mathematical equations of the three-degree-of-freedom system taking passenger seat dynamics can be derived using Newton's 2nd Law of Motion as follows:

$$m_1 \ddot{x}_1 + k_1(x_1 - x_2) + c_1(\dot{x}_1 - \dot{x}_2) + F_{MR} = 0 \quad (1)$$

$$m_2 \ddot{x}_2 - k_1(x_1 - x_2) - c_1(\dot{x}_1 - \dot{x}_2) + k_2(x_2 - x_3) + c_2(\dot{x}_2 - \dot{x}_3) - F_{MR} = 0 \quad (2)$$

$$m_3 \ddot{x}_3 - k_2(x_2 - x_3) - c_2(\dot{x}_2 - \dot{x}_3) + k_t(x_3 - x_r) = 0 \quad (3)$$

where x_1 , \dot{x}_1 , and \ddot{x}_1 are the displacement, velocity and acceleration of the passenger seat respectively; x_2 , \dot{x}_2 and \ddot{x}_2

are the displacement, velocity and acceleration of the sprung mass, respectively; x_3 , \dot{x}_3 and \ddot{x}_3 are the displacement, velocity and acceleration of the unsprung mass respectively; x_r is the road input variation.

IV. FUZZY LOGIC CONTROLLER DESIGN

Fuzzy logic control provides convenience to control system designers and engineers in the development of technology for performance improvement of systems whose exact mathematical modeling and numerical analysis is practically not feasible. Fuzzy controller works on the principle of rule base writing, based on the acquired knowledge and real life experience of particular process or system by the human operator or worker. The main reason for selecting fuzzy controller is its design simplicity, user friendly approach, ability to provide desired performance in vibration control applications and adjustment as well as setting of design parameters as per requirement during testing, before assembling and implementing it in vehicle suspension system.

In present case, for Fuzzy controller working, input-output variables for the concerned dynamic system must be defined. The Fuzzy controller used in present case is based on two-input variables and providing output as a single variable. All of the considered input and output variables for Forward FLC (FFLC) and Inverse FLC (IFLC) are defined with 12 linguistic grades as : NH (Negative High), NM (Negative Medium), NS (Negative Small), ZR (Zero), PS (Positive Small), PM (Positive Medium), PH (Positive High), ZR (Zero), S (Small), H (High), VH (Very High) and VVH (Very Very High) respectively.

The membership function shapes are selected based on the required performance as well as control system designer's knowledge and experience. In present case, a combination of trapezium and triangular form shapes is used for the input and output membership functions because the generated output response is better as evaluated by trial and error method. The membership function curves of the two inputs as passenger seat velocity (V_p) and secondary suspension velocity (V_{rel}) for FFLC are shown in Fig. 3 (a) while the single output from controller in terms of desired damping force (F_d) is shown in Fig. 3 (b). The input-output membership function plots used in Inverse fuzzy controller are shown in Fig. 4 providing the output in terms of supplied current (I).

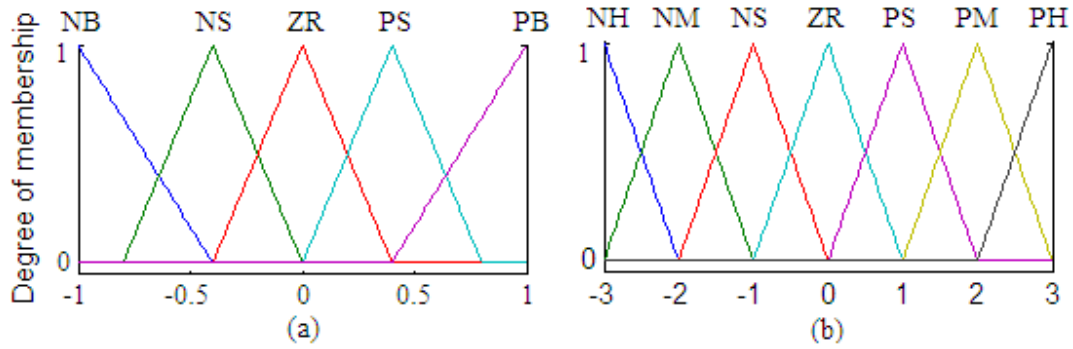

Fig. 3 MFs for FFLC (a) Input side, V_p and V_{rel} (b) Output side, F_d

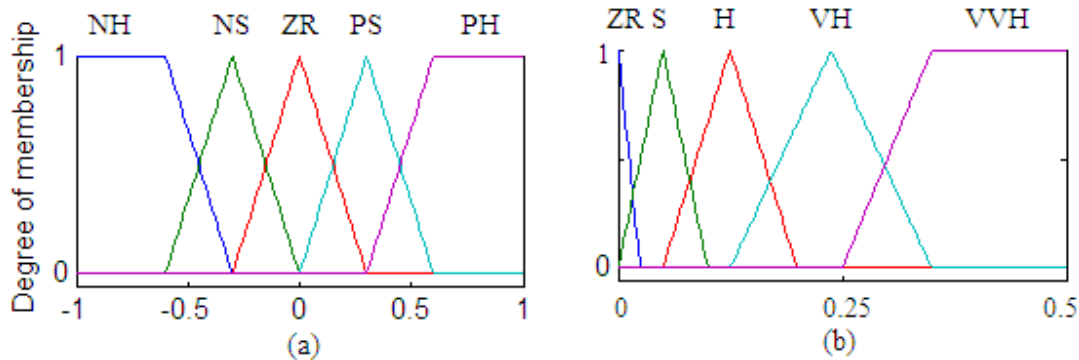

Fig. 4 MFs for IFLC (a) Input side, V_{rel} and F_d (b) Output side, I

To improve the passenger ride comfort and safety issues in travelling vehicle the written rule base for forward and inverse controller working are summarized in Tables II and III. The desired damping force from FFLC are computed using rule base in Table II while generation of control current signal as output from IFLC and presented in Table III.

TABLE II
FORWARD FUZZY RULE BASE

V_{rel} / V_p	NH	NS	ZR	PS	PH
NH	PH	PM	PS	PS	ZR
NS	PM	PS	PS	ZR	NS
ZR	PM	PS	ZR	NS	NM
PS	PS	ZR	NS	NS	NM
PH	ZR	NS	NS	NM	NH

TABLE III
INVERSE FUZZY RULE BASE

V_{rel} / F_d	NH	NS	ZE	PS	PH
NH	VVH	VH	VH	H	ZR
NS	VH	H	S	ZR	H
ZE	VH	S	ZR	S	VH
PS	H	ZR	S	H	VH
PH	ZR	H	VH	VH	VVH

Fuzzy inference criterion involves mapping/ conversion of input data to an output by application of fuzzy logic. In present work, for both FFLC and IFLC, Mamdani method is used in fuzzy inference system since it is mostly used fuzzy methodology. Centroid method is selected for defuzzification stage to get mathematical values from linguistic data.

V. SIMULATION WORK

Selected parameters for simulation work of quarter car model with three-degrees-of-freedom with symbols and values are listed in Table IV. Bump type of road input excitation, responses of the secondary suspension system having passenger seat using passive and semi-active suspension system are shown in Fig. 5 while the calculate RMS and Peak values are tabulated in Table V whereas the obtained input-output surfaces for FFLC and IFLC are shown in Figs. 6 and 7 respectively.

TABLE IV
PARAMETERS OF QUARTER CAR MODEL

Passenger seat mass, m_1	75 kg
Sprung mass, m_2	350 kg
Unsprung mass, m_3	45 kg
Primary suspension damping, c_1	1400 N/m/s
Secondary suspension damping, c_2	750 N/m/s
Primary suspension stiffness, k_1	24000 N/m
Secondary suspension damping, k_2	7500N/m
Tire stiffness, k_t	160,000 N/m

From Figs. 5 (b)-(d), it can be seen that controlled semi-active suspension system integrated with MR shock absorbers successfully suppresses the effects of vibrations as transmitted from unsprung mass to passenger seat resulting into improved performance related to passenger seat acceleration (\ddot{x}_1), passenger seat displacement (x_1) and secondary suspension system deflection ($x_1 - x_2$) compared to the uncontrolled or passive suspension system showing the advantages of using

MR shock absorbers in semi-active suspension systems for vibration control system applications when passenger ride comfort and safety issues are taken into account.

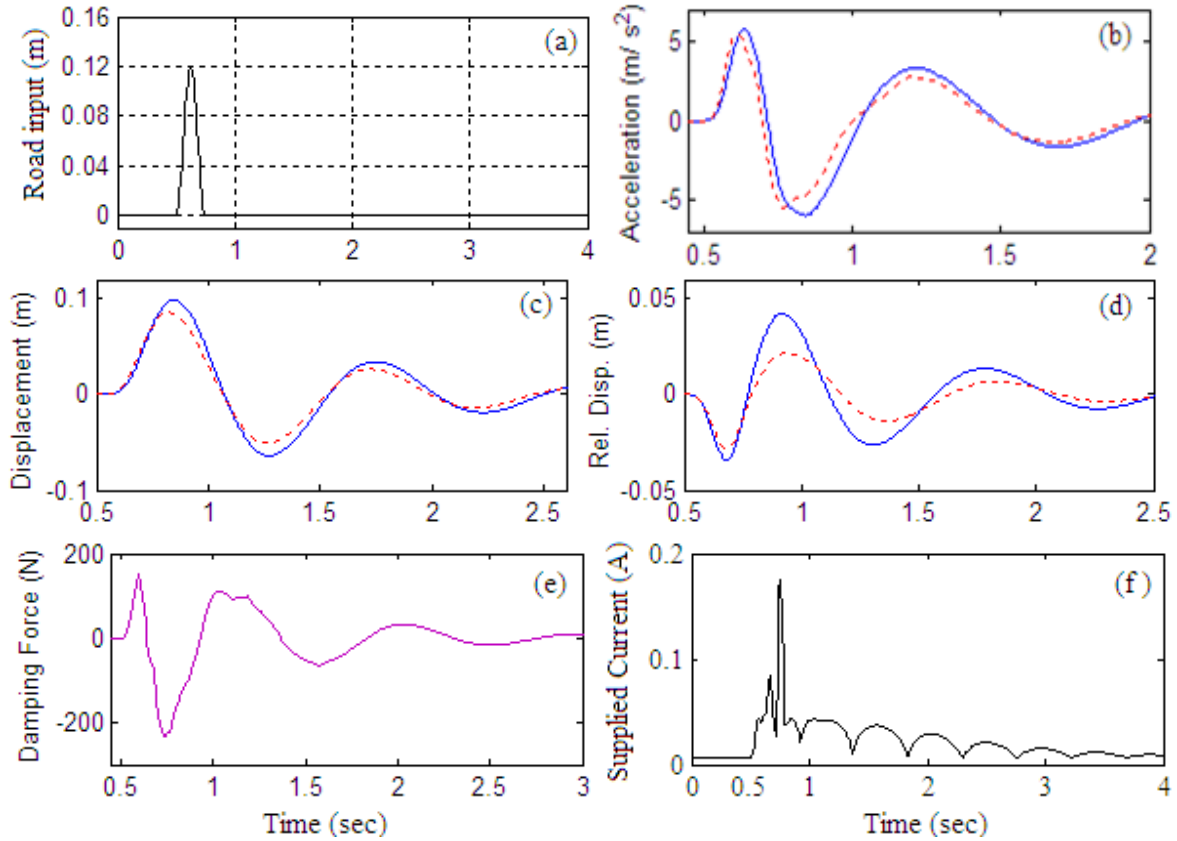

Fig. 5 Time history plots of passenger seat response under bump road excitation with vehicle speed of 40 km/h (a) input road profile (b) seat acceleration (c) seat displacement (d) secondary suspension deflection (e) the desired damping force (f) supplied current. (— uncontrolled, - - - controlled)

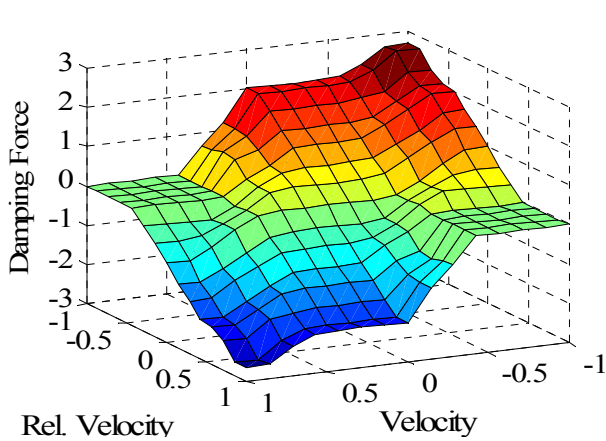

Fig. 6 Forward FLC input/output surface

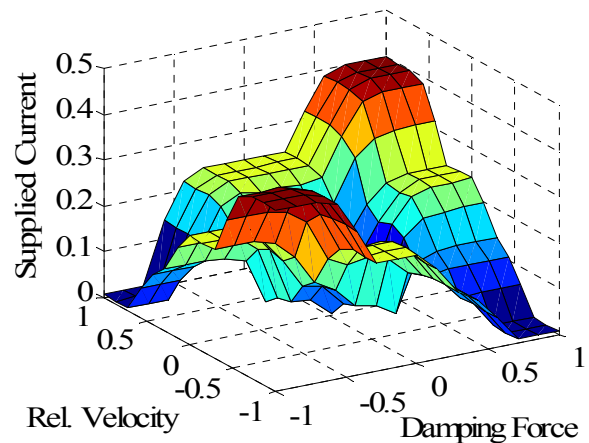

Fig. 7 Inverse FLC input/output surface

TABLE V
 RMS AND PEAK VALUES FOR QUARTER CAR MODEL AT 40 KM/HR

Parameter	RMS values			Peak values		
	Passive	Semi-active	Reduction (%)	Passive	Semi-active	Reduction (%)
\ddot{x}_1	1.698	1.489	12.31	5.840	5.494	5.91
x_1	0.029	0.024	15.68	0.098	0.086	12.67
$x_1 - x_2$	0.012	0.007	38.87	0.040	0.021	48.39

VI. ROBUSTNESS ANALYSIS

Figs. 8 & 9 show the robust stability and performance of semi-active quarter car system integrated with Fuzzy Logic Controller when the combination of variation in passenger mass as well as road height magnitude is taken for study using simulation work. Figs. 8 (a), (b) show the response surface plots of passenger seat in terms of root mean square (RMS) values of passenger seat acceleration and acceleration settling time (sec) while Figs. 9 (a), (b) represent the response surface plots of passenger seat in terms of root mean square (RMS) values of passenger seat displacement and displacement settling time (sec) respectively, taking uncontrolled and controlled systems into account. It can be observed and concluded from Figs. 8 and 9 that semi-active controlled suspension system delivers much better performance and shows stability in enhancing passenger ride comfort compared to uncontrolled suspension system, when the uncertainty parameters are taken, which affect the considered system.

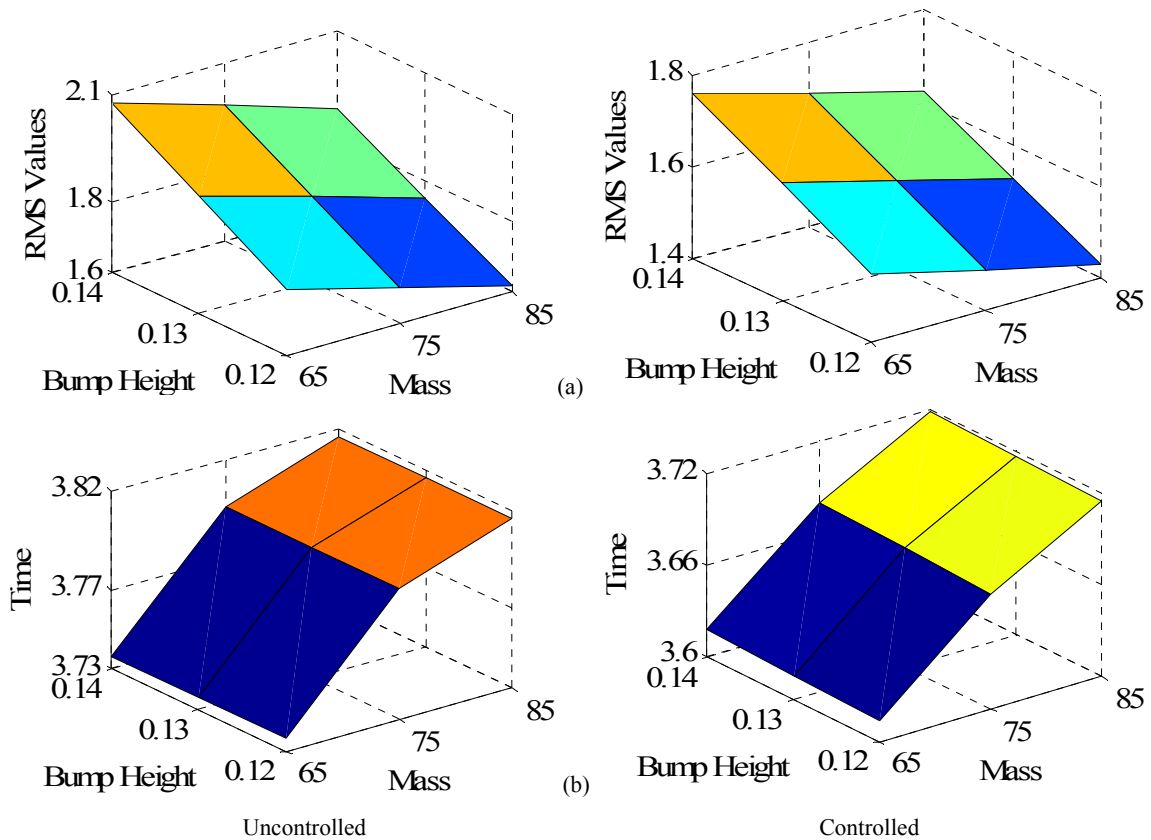

Fig. 8 (a) RMS Acceleration plot (b) Acceleration settling time plot

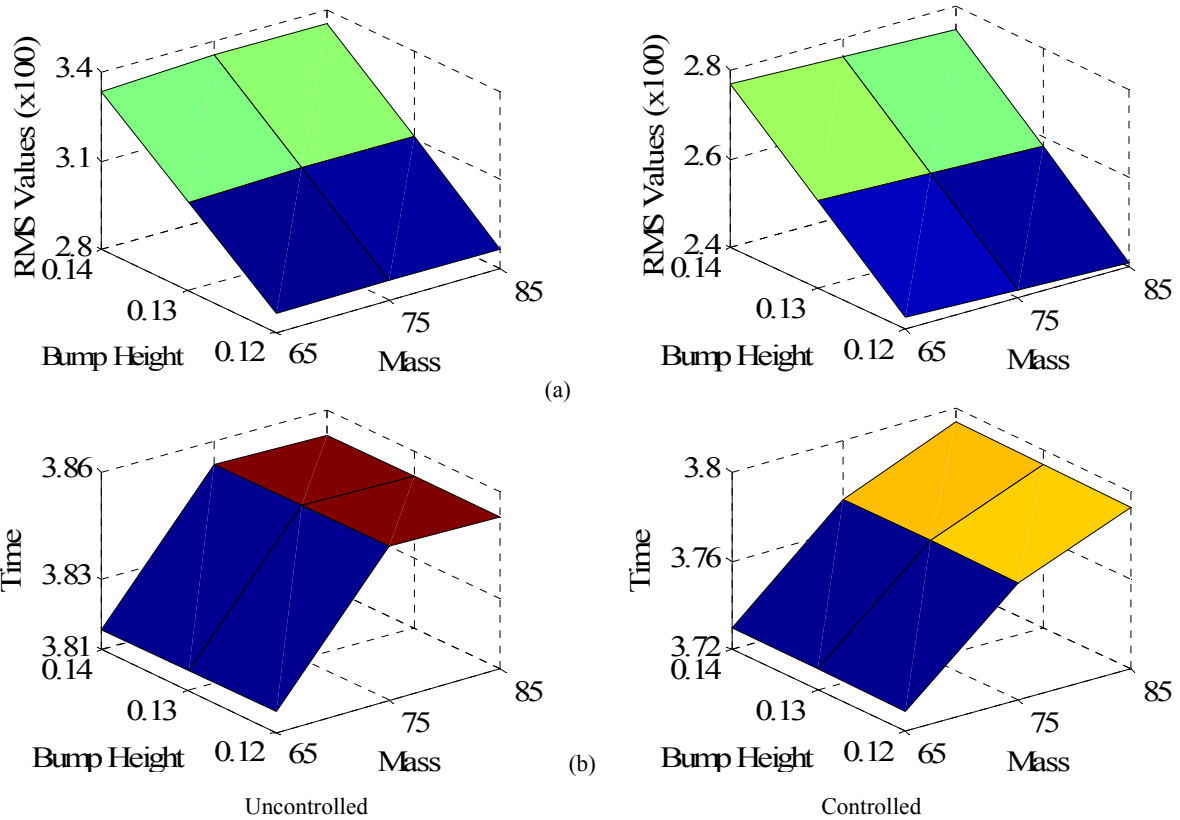

Fig. 9 (a) RMS Displacement plot (b) Displacement settling time plot

VII. CONCLUSION

In present paper, passenger ride comfort issues has been studied through simulation work using quarter car model with three degrees of freedom by taking acceleration and displacement factors into account. It has been observed that semi-active vehicle system integrated with MR shock absorber provides better performance in terms of controlling vibration effects on travelling passenger when different parameters such as passenger mass and road height are considered for simulation purpose. The designed Fuzzy controller can be successfully implemented for proper working of assembled MR shock absorber. Finally, it can be concluded that semi-active suspension system provides much better performance compared to passive suspension system for passenger ride comfort and safety in travelling vehicles.

REFERENCES

- [1] Carlson, J. D., and J. L. Sproston, "Controllable Fluids in 2000- Status of ER and MR Fluid Technology", Proc. of Actuator 2000, Bremen, 126-130, 2000.
- [2] G.Z. Yao et al., "MR damper and its application for semi-active control of vehicle suspension system", Mechatronics, Vol. 12, Issue 7, 963-973, 2002.
- [3] C.Y. Lai, W.H. Liao, "Vibration control of a suspension system via a magnetorheological fluid damper", Journal of Vibration and Control, Vol. 8, Issue 4, 527-547, 2002.
- [4] A. Hac and I. Youn, "Optimal semi-active suspension with preview based on a quarter car model", Trans. ASME, J. Vib. Acoust., Vol. 114, Issue 1, 84-92, 1992.
- [5] M.M. ElMadany and Z.S. Abduljabbar, "Linear quadratic Gaussian control of a quarter-car suspension", Veh. Syst. Dyn., Vol. 32, Issue 6, 479-497, 1999.
- [6] S.B. Choi, Y.T. Choi, and D.W. Park, "A sliding mode control of a full-car electrorheological suspension system via hardware-in-the-loop simulation", Trans. ASME, J. Dyn. Syst. Meas. Control, Vol. 122, Issue 1, 114-121, 2000.
- [7] M. Ahmadian and C.A. Pare, "A quarter-car experimental analysis of alternative semiactive control methods", J. Intell. Mater. Syst. Struct., Vol. 11, Issue 8, 604-612, 2000.
- [8] M. Yokoyama, J.K. Hedrick, S. Toyama, "A model following sliding mode controller for semi-active suspension systems with MR dampers", in: Proceedings of the American Control Conference, 2652-2657, 2001.
- [9] K.C. Schurter and P.N. Roschke, "Neuro-fuzzy control of structures using acceleration feedback", Smart Mater. Struct., Vol. 10, Issue 4, 770-779, 2001.
- [10] V.S. Atray and P.N. Roschke, "Neuro-fuzzy control of railcar vibrations using semiactive dampers", Comput. Aided Civil Infrastruct. Eng., Vol. 19, Issue 2, 81-92, 2004.
- [11] I. Fialho and G.J. Balas, "Road adaptive active suspension design using linear parameter-varying gain scheduling", IEEE Trans. Control Syst. Technol., Vol. 10, Issue 1, 43-54, 2002.
- [12] S.B. Choi, H.S. Lee, and Y.P. Park, "H ∞ control performance of a full-vehicle suspension featuring magnetorheological dampers", Veh. Syst. Dyn., Vol. 38, Issue 5, 341-360, 2002.
- [13] H.P. Du, K.Y. Sze, and J. Lam, "Semi-active H-infinity control of vehicle suspension with magneto-rheological dampers", J. Sound Vib., Vol. 283, Issue 3-5, 981-996, 2005.
- [14] Y. Liu, T. Waters, M. Brennan, "A comparison of semi-active damping control strategies for vibration isolation of harmonic disturbances", Journal of Sound and Vibration, Volume 280, Issue 1-2, 21-39, 2005.
- [15] M. Yu, C.R. Liao, W.M. Chen, and S.L. Huang, "Study on MR semi-active suspension system and its road testing", J. Intell. Mater. Syst. Struct., Vol. 17, Issue 8-9, 801-806, 2006.
- [16] M. Yu, X.M. Dong, S.B. Choi, and C.R. Liao, "Human simulated intelligent control of vehicle suspension system with MR dampers", J. Sound Vib., Vol. 319, Issue 3-5, 753-767, 2009.

- [17] Schurter K C and Roschke P N, "Fuzzy modeling of a magnetorheological damper using ANFIS", Proc. 9th IEEE Int. Conf. on Fuzzy Systems, Vol. 1, 122-7, 2000.
- [18] Schurter K C and Roschke P N, "Neuro-fuzzy control of structures using magnetorheological dampers", Proc. American Control Conf., Vol. 2, 1097-102, 2001.
- [19] Atray V S and Roschke P N, "Neuro-fuzzy control of railcar vibrations using semiactive dampers", Comput.-Aided Civil Infrastruct. Eng., Vol. 19, 81-92, 2004.
- [20] Choi S B, Lee S K and Park Y P, "A hysteresis model for the field-dependent damping force of a magnetorheological damper", J. Sound Vib., Vol. 245, 375-83, 2001.
- [21] Jin G, Sain et al., "Modeling MR-dampers: a nonlinear blackbox approach", Proc. American Control Conf., Vol. 1, 429-34, 2001.
- [22] Jin G, Sain M K and Spencer B E Jr, "Nonlinear blackbox modeling of MR-dampers for civil structural control", IEEE Trans. Control Syst. Technol., Vol. 13, 345-55, 2005.
- [23] Savaresi S M, Bittanti S and Montiglio M, "Identification of semi-physical and black-box non-linear models: the case of MR-dampers for vehicles control", Automatica, Vol. 41, 113-27, 2005.
- [24] Chang C. C. and Roschke P., "Neural network modeling of a magnetorheological damper", J. Intell. Mater. Syst. Struct., Vol. 9, 755-64, 1998.
- [25] Chang C. C. and Zhou L., "Neural network emulation of inverse dynamics for a magnetorheological damper", J. Struct. Eng. ASCE, Vol. 128, 231-9, 2002.
- [26] Wang X, Chang C C and Du F, "Achieving a more robust neural network model for control of a MR damper by signal sensitivity analysis", Neural Comput. Appl., Vol. 10, 330-8, 2002.
- [27] Jin G, Sain M K and Spencer B F Jr, "Modeling MR-dampers: the ridgenet estimation approach", Proc. 2002 American Control Conf. 3, 2457-62, 2002.
- [28] Atray V S and Roschke P N, "Design, fabrication, testing and fuzzy modeling of a large magnetorheological damper for vibration control in a railcar", Proc. 2003 IEEE/ASME Joint Rail Conf., 223-9, 2003.
- [29] Koga K and Sano A, "Query-based approach to prediction of MR damper force with application to vibration control", Proc. American Control Conf., 3259-65, 2006.
- [30] Wen, Y. K., "Method for random vibration of hysteretic systems", J. Engineering Mechanics Division, ASCE, Vol. 102(EM2, 249-263), 1976.
- [31] R. Stanway, J.L. Sproston, and N.G. Stevens, "Non-linear modelling of an electro-rheological vibration damper", J. Electrostat., No. 20, Vol. 2, 167-184, 1987.
- [32] B.F. Spencer et al., "Phenomenological model for magnetorheological dampers", J. Eng. Mech. ASCE, Vol. 123, Issue 3, 230-238, 1997.
- [33] N.M.Wereley, L. Pang, and G.M. Kamath, "Idealized hysteresis modeling of electrorheological and magnetorheological dampers", J. Intell. Mater. Syst. Struct., Vol. 9, Issue 8, 642-649, 1998.
- [34] W.H. Li et al., "Testing and steady state modeling of a linear MR damper under sinusoidal loading", Smart Mater. Struct., Vol. 9, Issue 1, 95-102, 2000.
- [35] R. Jimnez and L. Alvarez, "Real time identification of structures with magnetorheological dampers", 41st IEEE Conference on Decision and Control, Las Vegas, NV, 2002.
- [36] Q. Zhou, S. R. K. Nielsen, and W.L. Qu, "Semi-active control of three-dimensional vibrations of an inclined sag cable with magnetorheological dampers", J. Sound Vib., Vol. 296, Issue 1-2, 1-22, 2006.
- [37] N.M. Kwok et al., "A novel hysteretic model for magnetorheological fluid dampers and parameter identification using particle swarm optimization", Sens. Actuator A, Phys., Vol. 132, Issue 2, 441-451, 2006.
- [38] Dinh Quang Truong, and Kyoung Kwan Ahn, "Identification and application of black-box model for a self-sensing damping system using a magneto-rheological fluid damper", Sensors and Actuators A: Physical, Vol. 161, Issue 1-2, 305-321, 2010.

Faridabad, Haryana, India. His research areas of interest are noise, vibration and ride quality related to semi-active and active vehicle suspension system.



Dr. M.L. Aggarwal has done B.Sc. (Mechanical Engg.) from REC Kurukshetra, Haryana, India in 1988. He further completed his M.Tech. and Ph.D. from IIT New Delhi in 2003 and JMI New Delhi in 2007 respectively in the area of Design of Mechanical equipments. He has been working in YMCA University of Science & Technology Faridabad, Haryana, India since 1989. He has published 40 papers in International / National Journals in the relevant areas of design engineering. His research areas of interest are materials, shot peening and design.



Devdutt is PhD student in the Department of Mechanical Engineering, YMCA University of Science and Technology, Faridabad, Haryana, India. Presently he is working as Assistant Professor in the Department of Mechanical Engineering, Faculty of Engineering and Technology, Manav Rachna International University,