

# A Fuzzy Nonlinear Regression Model for Interval Type-2 Fuzzy Sets

O. Poleshchuk, E. Komarov

**Abstract**—This paper presents a regression model for interval type-2 fuzzy sets based on the least squares estimation technique. Unknown coefficients are assumed to be triangular fuzzy numbers. The basic idea is to determine aggregation intervals for type-1 fuzzy sets, membership functions of whose are low membership function and upper membership function of interval type-2 fuzzy set. These aggregation intervals were called weighted intervals. Low and upper membership functions of input and output interval type-2 fuzzy sets for developed regression models are considered as piecewise linear functions.

**Keywords**—Interval type-2 fuzzy sets, fuzzy regression, weighted interval.

## I. INTRODUCTION

THE methods of fuzzy regression analysis have received a lot of developing in the past years [1]-[24]. Advantages and differences existing methods are detailed in the [14], [24].

However, all these methods to the appearance of [24] have been limited by consideration of type-1 fuzzy sets (T1 FSs). This paper presents the first linear regression model for interval type-2 fuzzy sets. The development of such model has been quite logical and expected because the fuzzy regression analysis must provide a way to model the observed fuzzy data such as words models of whose may be interval type-2 fuzzy sets (IT2 FSs), proposed by L. Zadeh and developed by J. M. Mendel [25]. Evaluation of qualitative characteristics has always been a non-trivial task, since in most cases it is caused by involvement experts. Quite often, expert opinions are the only means of evaluations of qualitative characteristics because of the lack of reliable mathematical models, accurate statistical information and a number of other reasons. The problem of aggregation of information obtained from a group of experts is not new, but the relevance to solve it is not lost, because along with the development of new and more complex systems in different fields of human activity, more complex procedures for their expertise and responsibility of the experts for their solutions and approaches. It is necessary not only to obtain information from experts, but also to process it keeping unique individual experience and knowledge maximally.

Methods of the theory of expert evaluation have begun to fail, since procedures of evaluation complicated considerably,

O. Poleshchuk is with the Mathematical Department, Moscow State Forest University, Mytishi, Moscow region, 141005, Russia (phone: +7495-586-93-35; fax: +7495-586-93-35; e-mail: olga.m.pol@yandex.ru).

E. Komarov is with the Electrical Engineering Department, Moscow State Forest University, Mytishi, Moscow region, 141005, Russia (phone: +7495-586-93-35; fax: +7495-586-93-35; e-mail: komarov@mgul.ac.ru).

increased the cost of failure and accordingly responsibility of expert for evaluation individually as well as in cooperative decision making. IT2 FSs have enough degrees of freedom to save individual expert information and to obtain a group expert model. In order to include IT2 FSs into a nonlinear regression, a need for developing a new method exists. It is worth mentioning that if many nonlinear classical regression models can be reduced to linear models by means of corresponding replacements, nonlinear fuzzy regression models are more complicated to reduce. The matter is that, for example, while multiplying fuzzy numbers it is not always possible to get an analytical form for membership function of a fuzzy number which is a result out of the multiplication. The method of regression's creation develops the idea presented in [24]. It allows determining aggregation intervals for T1 FSs, membership functions of whose are low membership function (LMF) and upper membership function (UMF) of IT2 FS. These aggregation intervals were called weighted intervals [26]. The developed method extends a group of initial data membership functions as well as a group of regression models.

## II. WEIGHTED INTERVALS FOR INTERVAL TYPE-2 FUZZY SETS

Let us consider a IT2 FS  $\tilde{A}$  shown in Fig. 1.

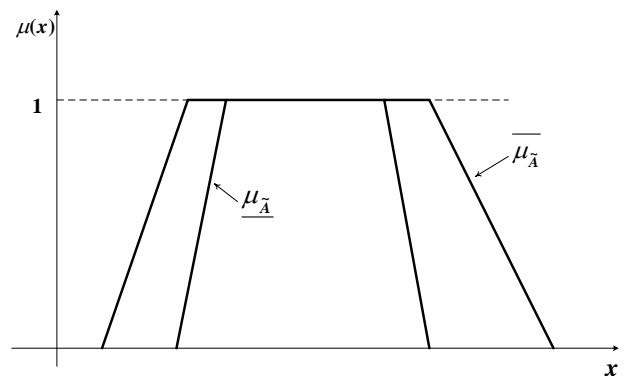

Fig. 1 IT2 FS  $\tilde{A}$  with LMF  $\underline{\mu}_{\tilde{A}}$  and UMF  $\overline{\mu}_{\tilde{A}}$

This IT2 FS is defined by LMF and UMF, which are denoted by  $\underline{\mu}_{\tilde{A}}$  and  $\overline{\mu}_{\tilde{A}}$  respectively,  $\underline{\mu}_{\tilde{A}} = (a_1^L, a_2^L, a_l^L, a_r^L)$ ,  $\overline{\mu}_{\tilde{A}} = (a_1^U, a_2^U, a_l^U, a_r^U)$ . The first two parameters in brackets are abscissas of the apexes of the trapezium upper bases that is a graph of the corresponding membership function, while

the last two parameters are the lengths of the left and right trapezium wings correspondingly.

The definition of weighted point  $B$  for a triangular number  $\tilde{B} = (b, b_l, b_r)$  was given in [10]:

$$B = \frac{\int_0^1 \left( \frac{B_\alpha^1 + B_\alpha^2}{2} \right) 2\alpha d\alpha}{\int_0^1 2\alpha d\alpha} = \int_0^1 (B_\alpha^1 + B_\alpha^2) \alpha d\alpha = \int_0^1 (b - (1-\alpha)b_l + b + (1-\alpha)b_r) \alpha d\alpha = b + \frac{1}{6}(b_r - b_l).$$

According to this definition, we get weighted point of a triangular number, integrating the mid  $\alpha$ -cuts with a weight function equal to  $2\alpha$ . Using this definition we can see that two normalized symmetrical triangular numbers with different fuzzy widths are converted into one crisp number. For example, let consider two triangular fuzzy numbers:  $\tilde{A} = (2, 2, 2)$ ,  $\tilde{B} = (2, 1, 1)$ . The weighted points for numbers  $\tilde{A}, \tilde{B}$  we shall designate accordingly as  $A, B$ , then:

$$A = \int_0^1 (4 - 2(1-\alpha) + 2(1-\alpha)) \alpha d\alpha = 2, \\ B = \int_0^1 (4 - (1-\alpha) + (1-\alpha)) \alpha d\alpha = 2.$$

While this may not present a problem to solve a number of practical tasks, however, for example, in decision-making problems and some other problems the necessity arises to find aggregative indexes that will possibly accumulate different bounds of input fuzzy numbers.

That is why we propose to use the definition of weighted point for a triangular number in order to determine a weighted interval for a trapezoidal fuzzy number (as well as for a triangular number as a special case of a trapezoidal fuzzy number). It will allow keeping their informative properties.

Let define the weighted set for the trapezoidal fuzzy number  $\tilde{A} \equiv (a_1, a_2, a_l, a_r)$  as the set of weighted points of all triangular numbers  $\tilde{B} \equiv (b, b_l, b_r)$  that belong to the number  $\tilde{A}$ .

Proposition 1 [27]. The weighted set for the trapezoidal fuzzy number  $\tilde{A} = (a_1, a_2, a_l, a_r)$  is an interval  $[A_1, A_2]$ , such as  $A_1 = a_1 - \frac{1}{6}a_l$ ,  $A_2 = a_2 + \frac{1}{6}a_r$ .

We have called the interval  $[A_1, A_2]$  the weighted interval for trapezoidal fuzzy number  $\tilde{A} = (a_1, a_2, a_l, a_r)$ .

Let consider two triangular fuzzy numbers:  $\tilde{A} = (2, 2, 2)$ ,  $\tilde{B} = (2, 1, 1)$  again and define the weighted intervals  $[A_1, A_2]$ ,  $[B_1, B_2]$  for numbers  $\tilde{A}, \tilde{B}$ .

$$A_1 = \int_0^1 (4 - 2(1-\alpha)) \alpha d\alpha = 2 - 2 \times \frac{1}{6} = 1\frac{2}{3}, \\ A_2 = \int_0^1 (4 + 2(1-\alpha)) \alpha d\alpha = 2 + 2 \times \frac{1}{6} = 2\frac{1}{3}, \\ B_1 = \int_0^1 (4 - (1-\alpha)) \alpha d\alpha = 2 - \frac{1}{6} = 1\frac{5}{6}, \\ B_2 = \int_0^1 (4 + 2(1-\alpha)) \alpha d\alpha = 2 + \frac{1}{6} = 2\frac{1}{6}, \\ [A_1, A_2] = \left[ 1\frac{2}{3}, 2\frac{1}{3} \right], [B_1, B_2] = \left[ 1\frac{5}{6}, 2\frac{1}{6} \right].$$

It can be observed that the weighted points of  $\tilde{A}$  and  $\tilde{B}$  are the same while the weighted intervals for these fuzzy numbers are different. The greater the fuzzy widths, the greater the weighted interval is.

The weighted intervals are suggested to be used in situations where it is necessary to accumulate more information about fuzzy numbers than aggregative point crisp indexes contain when there is no requirement to get only aggregative numbers.

Proposition 2 [27]. The weighted interval for number  $\tilde{A} + \tilde{B}$  can be obtained as  $[A_1 + B_1, A_2 + B_2]$ , where  $[A_1, A_2], [B_1, B_2]$  are weighted intervals for trapezoidal numbers  $\tilde{A}, \tilde{B}$ .

Let us consider a nonnegative  $\tilde{A} = (a_1, a_2, a_l, a_r)$  and a triangular number  $\tilde{a} \equiv (b, b_l, b_r)$ .

Proposition 3 [27]. The boundaries of weighted interval  $[\theta_{\tilde{a}\tilde{A}}^1, \theta_{\tilde{a}\tilde{A}}^2]$  of product of fuzzy numbers  $\tilde{a}$  and  $\tilde{A}$  look like

$$\theta_{\tilde{a}\tilde{A}}^1 = b \left( a_q + (-1)^q \frac{1}{6} a_{M_q} \right) - b_l \left( \frac{1}{6} a_q + (-1)^q \frac{1}{12} a_{M_q} \right), \\ \theta_{\tilde{a}\tilde{A}}^2 = b \left( a_p + (-1)^p \frac{1}{6} a_{M_p} \right) + b_r \left( \frac{1}{6} a_p + (-1)^p \frac{1}{12} a_{M_p} \right), \\ q = \begin{cases} 1, b - b_l \geq 0 \\ 2, b + b_r < 0 \end{cases}, M_q = \begin{cases} l, q = 1 \\ r, q = 2 \end{cases}, \\ p = \begin{cases} 2, b - b_l \geq 0 \\ 1, b + b_r < 0 \end{cases}, M_p = \begin{cases} l, p = 1 \\ r, p = 2 \end{cases}.$$

Proposition 4 [27]. The boundaries of weighted interval  $[\theta_{\tilde{a}\tilde{A}^2}^1, \theta_{\tilde{a}\tilde{A}^2}^2]$  of product of fuzzy numbers  $\tilde{a}$  and  $\tilde{A}^2$  look like

$$\theta_{\tilde{a}\tilde{A}^2}^1 = b \left( a_q^2 + (-1)^q \frac{1}{3} a_q a_{M_q} + \frac{1}{12} a_{M_q}^2 \right) - b_l \left( \frac{1}{6} a_q^2 + (-1)^q \frac{1}{6} a_q a_{M_q} + \frac{1}{20} a_{M_q}^2 \right), \\ \theta_{\tilde{a}\tilde{A}^2}^2 = b \left( a_p^2 + (-1)^p \frac{1}{3} a_p a_{M_p} + \frac{1}{12} a_{M_p}^2 \right) + b_r \left( \frac{1}{6} a_p^2 + (-1)^p \frac{1}{6} a_p a_{M_p} + \frac{1}{20} a_{M_p}^2 \right).$$

Let us consider a nonnegative number  $\tilde{B} = (b_1, b_2, b_l, b_r)$ .

Proposition 5 [27]. The boundaries of weighted interval  $[\theta_{\tilde{a}\tilde{A}\tilde{B}}^1, \theta_{\tilde{a}\tilde{A}\tilde{B}}^2]$  of product of fuzzy numbers  $\tilde{a}, \tilde{A}, \tilde{B}$  look like

$$\theta_{\tilde{a}\tilde{A}\tilde{B}}^1 = b \left( a_q b_q + \frac{(-1)^q}{6} a_q b_{M_q} + \frac{(-1)^q}{6} b_q a_{M_q} + \frac{1}{12} a_{M_q} b_{M_q} \right) - b_l \left( \frac{1}{6} a_q b_q + \frac{(-1)^q}{12} a_q b_{M_q} + \frac{(-1)^q}{12} b_q a_{M_q} + \frac{1}{20} a_{M_q} b_{M_q} \right),$$

$$\theta_{\tilde{a}\tilde{A}\tilde{B}}^2 = b \left( a_p b_p + \frac{(-1)^p}{6} a_p b_{M_p} + \frac{(-1)^p}{6} b_p a_{M_p} + \frac{1}{12} a_{M_p} b_{M_p} \right) - b_r \left( \frac{1}{6} a_p b_p + \frac{(-1)^p}{12} a_p b_{M_p} + \frac{(-1)^p}{12} b_p a_{M_p} + \frac{1}{20} a_{M_p} b_{M_p} \right).$$

Definition 1. We shall call weighted intervals of a IT2 FS  $\tilde{A}$  the weighted intervals of LMF and UMF, which define IT2 FS  $\tilde{A}$ .

For example, weighted intervals  $[A_1^L, A_2^L][A_1^U, A_2^U]$  for IT2 FS  $\tilde{A}$ , defined by LMF  $\underline{\mu}_{\tilde{A}} = (a_1^L, a_2^L, a_l^L, a_r^L)$  and UMF  $\overline{\mu}_{\tilde{A}} = (a_1^U, a_2^U, a_l^U, a_r^U)$ , look like:

$$A_1^L = a_1^L - \frac{1}{6} a_l^L, A_2^L = a_2^L + \frac{1}{6} a_r^L,$$

$$A_1^U = a_1^U - \frac{1}{6} a_l^U, A_2^U = a_2^U + \frac{1}{6} a_r^U.$$

Let us define an affinity measure for two IT2 FSs  $\tilde{A}, \tilde{B}$  with weighed intervals  $[A_1^L, A_2^L][A_1^U, A_2^U], [B_1^L, B_2^L][B_1^U, B_2^U]$

$$f^2(\tilde{A}, \tilde{B}) = (A_1^L - B_1^L)^2 + (A_2^L - B_2^L)^2 + (A_1^U - B_1^U)^2 + (A_2^U - B_2^U)^2.$$

### III. PROBLEM FORMULATION AND SOLUTION

Let  $\tilde{Y}_i, i = \overline{1, n}$  are output IT2 FSs, defined by LMFs  $\underline{\mu}_{\tilde{Y}_i} = (y_1^{iL}, y_2^{iL}, y_l^{iL}, y_r^{iL}), i = \overline{1, n}$  and UMFs  $\overline{\mu}_{\tilde{Y}_i} = (y_1^{iU}, y_2^{iU}, y_l^{iU}, y_r^{iU}), y_1^{iU} - y_l^{iU} \geq 0, i = \overline{1, n}$ .

Let  $\tilde{X}_j^i, j = \overline{1, m}, i = \overline{1, n}$  input IT2 FSs, defined by LMFs  $\underline{\mu}_{\tilde{X}_j^i} = (x_1^{jiL}, x_2^{jiL}, x_l^{jiL}, x_r^{jiL})$  and UMFs  $\overline{\mu}_{\tilde{X}_j^i} = (x_1^{jiU}, x_2^{jiU}, x_l^{jiU}, x_r^{jiU}), x_1^{jiU} - x_l^{jiU} \geq 0, j = \overline{1, m}, i = \overline{1, n}$ . LMFs and UMFs of output and input IT2 FSs are trapezoidal fuzzy numbers.

The regression model relates  $\tilde{Y}$  (with meanings  $\tilde{Y}_i, i = \overline{1, n}$ ) to  $\tilde{X}_j, j = \overline{1, m}$  (with meanings  $\tilde{X}_j^i, j = \overline{1, m}, i = \overline{1, n}$ ) as follows:

$$\tilde{Y} = \tilde{a}_1 \tilde{X}_1^2 + \dots + \tilde{a}_m \tilde{X}_m^2 + \tilde{a}_{m+1} \tilde{X}_1 \tilde{X}_2 + \dots + \tilde{a}_{\frac{m(m+1)}{2}} \tilde{X}_{m-1} \tilde{X}_m + \tilde{a}_{\frac{m^2+m+2}{2}} \tilde{X}_1 + \dots + \tilde{a}_{\frac{m(m+3)}{2}} \tilde{X}_m + \tilde{a}_0,$$

where  $\tilde{a}_k \equiv (b^k, b_L^k, b_R^k), k = 0, \frac{m(m+3)}{2}$  are unknown coefficients of a regression model, which are defined as triangular numbers (not necessarily symmetrical).

The method of regression's creation is based on the transformation of the LMFs and UMFs of initial and model output IT2 FSs into weighted intervals.

Let us determine the weighed intervals  $[\theta_{\tilde{Y}_i}^{1L}, \theta_{\tilde{Y}_i}^{2L}], [\theta_{\tilde{Y}_i}^{1U}, \theta_{\tilde{Y}_i}^{2U}]$  for LMFs and UMFs of initial output data  $\tilde{Y}_i, i = \overline{1, n}$ :

$$\theta_{\tilde{Y}_i}^{1L} = y_1^{iL} - \frac{1}{6} y_l^{iL}, \theta_{\tilde{Y}_i}^{2L} = y_2^{iL} + \frac{1}{6} y_r^{iL},$$

$$\theta_{\tilde{Y}_i}^{1U} = y_1^{iU} - \frac{1}{6} y_l^{iU}, \theta_{\tilde{Y}_i}^{2U} = y_2^{iU} + \frac{1}{6} y_r^{iU}.$$

Let us determine the weighed intervals  $[\theta_{\tilde{Y}_i}^{1L}, \theta_{\tilde{Y}_i}^{2L}], [\theta_{\tilde{Y}_i}^{1U}, \theta_{\tilde{Y}_i}^{2U}]$  for LMFs and UMFs of model output data  $\hat{Y}, i = \overline{1, n}$  data, using propositions 1-5.

$$\theta_{\tilde{Y}_i}^{1L}(b^k, b_L^k, b_R^k) = b^0 - \frac{1}{6} b_l^0 + \sum_{j=1}^m \theta_{\tilde{a}_j \tilde{X}_j^i}^{1L} (b^j, b_l^j, b_r^j) + \sum_{j=2}^m \theta_{\tilde{a}_{m+j-1} \tilde{X}_1^i \tilde{X}_j^i}^{1L} (b^{m+j-1}, b_l^{m+j-1}, b_r^{m+j-1}) + \sum_{j=3}^m \theta_{\tilde{a}_{2m-j+3} \tilde{X}_2^i \tilde{X}_j^i}^{1L} (b^{2m-j+3}, b_l^{2m-j+3}, b_r^{2m-j+3}) + \dots + \theta_{\tilde{a}_{\frac{m^2+m}{2} \tilde{X}_1^i \tilde{X}_m^i}^{1L}} \left( b^{\frac{m^2+m}{2}}, b_l^{\frac{m^2+m}{2}}, b_r^{\frac{m^2+m}{2}} \right) + \sum_{j=1}^m \theta_{\tilde{a}_{\frac{m^2+m}{2}+j} \tilde{X}_j^i}^{1L} \left( b^{\frac{m^2+m}{2}+j}, b_l^{\frac{m^2+m}{2}+j}, b_r^{\frac{m^2+m}{2}+j} \right),$$

$$\theta_{\tilde{Y}_i}^{2L}(b^k, b_L^k, b_R^k) = b^0 + \frac{1}{6} b_r^0 + \sum_{j=1}^m \theta_{\tilde{a}_j \tilde{X}_j^i}^{2L} (b^j, b_l^j, b_r^j) + \sum_{j=2}^m \theta_{\tilde{a}_{m+j-1} \tilde{X}_1^i \tilde{X}_j^i}^{2L} (b^{m+j-1}, b_l^{m+j-1}, b_r^{m+j-1}) + \sum_{j=3}^m \theta_{\tilde{a}_{2m-j+3} \tilde{X}_2^i \tilde{X}_j^i}^{2L} (b^{2m-j+3}, b_l^{2m-j+3}, b_r^{2m-j+3}) + \dots +$$

$$\begin{aligned}
 & + \theta_{\tilde{a}_{\frac{m^2+m}{2}, \tilde{x}_{m-1}, \tilde{x}_m}^i}}^{2L} \left( b^{\frac{m^2+m}{2}}, b_l^{\frac{m^2+m}{2}}, b_r^{\frac{m^2+m}{2}} \right) + \\
 & + \sum_{j=1}^m \theta_{\tilde{a}_{\frac{m^2+m}{2}, \tilde{x}_j}^i}}^{2L} \left( b^{\frac{m^2+m+j}{2}}, b_l^{\frac{m^2+m+j}{2}}, b_r^{\frac{m^2+m+j}{2}} \right), \\
 \theta_{\tilde{Y}_i}^{1U} (b^k, b_l^k, b_r^k) & = b^0 - \frac{1}{6} b_l^0 + \sum_{j=1}^m \theta_{\tilde{a}_j, \tilde{x}_j^i}^{1U} (b^j, b_l^j, b_r^j) + \\
 & + \sum_{j=2}^m \theta_{\tilde{a}_{m+j-1}, \tilde{x}_1^i, \tilde{x}_j^i}^{1U} (b^{m+j-1}, b_l^{m+j-1}, b_r^{m+j-1}) + \\
 & + \sum_{j=3}^m \theta_{\tilde{a}_{2m-j+3}, \tilde{x}_2^i, \tilde{x}_j^i}^{1U} (b^{2m-j+3}, b_l^{2m-j+3}, b_r^{2m-j+3}) + \dots + \\
 & \theta_{\tilde{a}_{\frac{m^2+m}{2}, \tilde{x}_{m-1}, \tilde{x}_m}^i}}^{1U} \left( b^{\frac{m^2+m}{2}}, b_l^{\frac{m^2+m}{2}}, b_r^{\frac{m^2+m}{2}} \right) + \\
 & + \sum_{j=1}^m \theta_{\tilde{a}_{\frac{m^2+m}{2}, \tilde{x}_j}^i}}^{1U} \left( b^{\frac{m^2+m+j}{2}}, b_l^{\frac{m^2+m+j}{2}}, b_r^{\frac{m^2+m+j}{2}} \right); \\
 \theta_{\tilde{Y}_i}^{2U} (b^k, b_l^k, b_r^k) & = b^0 + \frac{1}{6} b_r^0 + \sum_{j=1}^m \theta_{\tilde{a}_j, \tilde{x}_j^i}^{2U} (b^j, b_l^j, b_r^j) + \\
 & + \sum_{j=2}^m \theta_{\tilde{a}_{m+j-1}, \tilde{x}_1^i, \tilde{x}_j^i}^{2U} (b^{m+j-1}, b_l^{m+j-1}, b_r^{m+j-1}) + \\
 & + \sum_{j=3}^m \theta_{\tilde{a}_{2m-j+3}, \tilde{x}_2^i, \tilde{x}_j^i}^{2U} (b^{2m-j+3}, b_l^{2m-j+3}, b_r^{2m-j+3}) + \dots + \\
 & + \theta_{\tilde{a}_{\frac{m^2+m}{2}, \tilde{x}_{m-1}, \tilde{x}_m}^i}}^{2U} \left( b^{\frac{m^2+m}{2}}, b_l^{\frac{m^2+m}{2}}, b_r^{\frac{m^2+m}{2}} \right) + \\
 & + \sum_{j=1}^m \theta_{\tilde{a}_{\frac{m^2+m}{2}, \tilde{x}_j}^i}}^{2U} \left( b^{\frac{m^2+m+j}{2}}, b_l^{\frac{m^2+m+j}{2}}, b_r^{\frac{m^2+m+j}{2}} \right).
 \end{aligned}$$

where  $k = 0, \frac{m(m+3)}{2}$ .

Detailed presentation of these intervals is presented in [23]. LMFs and UMFs of model output data will not be trapezoidal fuzzy numbers. While multiplying fuzzy numbers it is not always possible to get an analytical form for membership function of a fuzzy number which is a result out of the multiplication. But we can always determine model output data with the help of  $\alpha$ -cuts. For example if  $\tilde{a} \equiv (b, b_l, b_r)$  is a negative fuzzy number ( $b + b_r < 0$ ),  $\tilde{A} = (a_1, a_2, a_l, a_r)$  is a nonnegative number ( $a_1 - a_l \geq 0$ ) then according to multiplication operation for fuzzy numbers, the  $\alpha$ -cut of  $\tilde{a}\tilde{A}$  looks like  $[C_\alpha^1, C_\alpha^2]$ , where

$$C_\alpha^1 = ba_2 + (1-\alpha)ba_r - (1-\alpha)b_l a_2 - (1-\alpha)^2 b_l a_r,$$

$$C_\alpha^2 = ba_1 + (1-\alpha)ba_l + (1-\alpha)b_r a_1 - (1-\alpha)^2 b_r a_l.$$

If  $\tilde{a} \equiv (b, b_l, b_r)$  is a nonnegative fuzzy number ( $b - b_l \geq 0$ ) and  $\tilde{A} = (a_1, a_2, a_l, a_r)$  is a nonnegative number ( $a_1 - a_l \geq 0$ ) then according to multiplication operation for fuzzy numbers, the  $\alpha$ -cut of  $\tilde{a}\tilde{A}$  looks like  $[C_\alpha^1, C_\alpha^2]$ , where

$$C_\alpha^1 = ba_1 - (1-\alpha)ba_l - (1-\alpha)b_r a_1 + (1-\alpha)^2 b_r a_l,$$

$$C_\alpha^2 = ba_2 + (1-\alpha)ba_r + (1-\alpha)b_l a_2 + (1-\alpha)^2 b_l a_r.$$

Let us consider a functional

$$\begin{aligned}
 F(b^k, b_l^k, b_r^k) & = \sum_{i=1}^n f^2(\hat{Y}_i, \tilde{Y}_i) = \\
 & \sum_{i=1}^n \left[ (\theta_{\tilde{Y}_i}^{1L} - \theta_{\tilde{Y}_i}^{1U})^2 + (\theta_{\tilde{Y}_i}^{2L} - \theta_{\tilde{Y}_i}^{2U})^2 \right] + \\
 & + \sum_{i=1}^n \left[ (\theta_{\tilde{Y}_i}^{1U} - \theta_{\tilde{Y}_i}^{1L})^2 + (\theta_{\tilde{Y}_i}^{2U} - \theta_{\tilde{Y}_i}^{2L})^2 \right] = \\
 & \sum_{i=1}^n \left[ \left( \theta_{\tilde{Y}_i}^{1L} - y_1^{iL} + \frac{1}{6} y_l^{iL} \right)^2 + \left( \theta_{\tilde{Y}_i}^{2L} - y_2^{iL} - \frac{1}{6} y_r^{iL} \right)^2 \right] + \\
 & + \sum_{i=1}^n \left[ \left( \theta_{\tilde{Y}_i}^{1U} - y_1^{iU} + \frac{1}{6} y_l^{iU} \right)^2 + \left( \theta_{\tilde{Y}_i}^{2U} - y_2^{iU} - \frac{1}{6} y_r^{iU} \right)^2 \right],
 \end{aligned}$$

which characterizes an affinity measure between initial and model output data.

The optimization problem is set as follows:

$$F(b^k, b_l^k, b_r^k) = \sum_{i=1}^n f^2(\hat{Y}_i, \tilde{Y}_i) \rightarrow \min,$$

$$b_l^k \geq 0, b_r^k \geq 0, k = 0, \frac{m(m+3)}{2}.$$

Since  $\theta_{\tilde{Y}_i}^{1L}, \theta_{\tilde{Y}_i}^{2L}, \theta_{\tilde{Y}_i}^{1U}, \theta_{\tilde{Y}_i}^{2U}$  and are piecewise linear functions in the field  $b_L^k \geq 0, b_R^k \geq 0, k = 0, \frac{m(m+3)}{2}$ , then  $F$  is piecewise differentiable function, and solutions of an optimization problem are determined by means of known methods [28].

Let  $\hat{Y}_i, i = \overline{1, n}$  are model output IT2 FSs, defined by LMFs  $\mu_{\hat{Y}_i} = (v_1^{iL}, v_2^{iL}, v_l^{iL}, v_r^{iL}), i = \overline{1, n}$  and UMFs  $\mu_{\hat{Y}_i} = (v_1^{iU}, v_2^{iU}, v_l^{iU}, v_r^{iU}), i = \overline{1, n}$ . After obtaining  $\hat{Y}_i, i = \overline{1, n}$  a problem of identifying them with initial collection of words  $Y_k, k = \overline{1, p}$ , that formalized with the help of IT2 FSs  $\tilde{Y}_k, k = \overline{1, p}$  defined by LMFs  $\mu_{\tilde{Y}_k} = (y_1^{kL}, y_2^{kL}, y_l^{kL}, y_r^{kL}), k = \overline{1, p}$  and UMFs  $\mu_{\tilde{Y}_k} = (y_1^{kU}, y_2^{kU}, y_l^{kU}, y_r^{kU}), k = \overline{1, p}$  appears.

The weighted intervals for LMF and UMF of model  $\hat{Y}_i$ ,  $i = \overline{1, n}$  are designated by  $[C_1^{iL}, C_2^{iL}]$ ,  $[C_1^{iU}, C_2^{iU}]$ ,  $i = \overline{1, n}$  accordingly. The weighted intervals for LMF and UMF of  $\tilde{Y}_k$ ,  $k = \overline{1, p}$  are designated by  $[D_1^{kL}, D_2^{kL}]$ ,  $[D_1^{kU}, D_2^{kU}]$ ,  $k = \overline{1, p}$  accordingly.

Let

$$f^2(\hat{Y}_i, \tilde{Y}_k) = (C_1^{iL} - D_1^{kL})^2 + (C_2^{iL} - D_2^{kL})^2 + (C_1^{iU} - D_1^{kU})^2 + (C_2^{iU} - D_2^{kU})^2, i = \overline{1, n}, k = \overline{1, p}$$

The model  $\hat{Y}_i$  is identified to  $Y_s$ , if

$$f^2(\hat{Y}_i, \tilde{Y}_s) = \min_k f^2(\hat{Y}_i, \tilde{Y}_k), k = \overline{1, p}.$$

#### IV. CONCLUSION

A method for a multiple fuzzy nonlinear regression was developed in this paper. The input and output data of the regression model are interval type-2 fuzzy sets. The basic idea of this paper is to determine aggregation intervals for trapezoidal fuzzy numbers, membership functions of whose are low membership function and upper membership function of interval type-2 fuzzy sets, to determine an affinity measure for two interval type-2 fuzzy sets based on these intervals and to use the least squares estimation technique. The proposed method extends a group of initial data membership functions (the regression model can be applied not only to type-1 fuzzy sets, but also to interval type-2 fuzzy sets) as well as a group of regression models.

#### REFERENCES

- [1] H. Tanaka, "Fuzzy data analysis by possibilistic linear models", Fuzzy Sets and Systems, vol. 21, pp. 363-375, 1991.
- [2] H. Tanaka, S. Uejima, K. Asai, "Linear regression analysis with fuzzy model", IEEE. Systems, Trans. Systems Man Cybernet. SMC-2, pp. 903-907, 1982.
- [3] H. Tanaka, H. Ishibuchi, "Identification of possibilistic linear models" Fuzzy Sets and Systems, 1991, vol. 41, pp. 145 - 160.
- [4] H. Tanaka, H. Ishibuchi, S. Yoshikawa, "Exponential possibility regression analysis," Fuzzy Sets and Systems, 1995, vol. 69, pp. 305 - 318.
- [5] A. Celmins, "Least squares model fitting to fuzzy vector data", Fuzzy Sets and Systems, 1987, vol. 22, pp. 245-269.
- [6] A. Celmins, "Multidimensional least-squares model fitting of fuzzy models", Math. Modeling, 1987, vol. 9, pp. 669-690.
- [7] D.A. Sabic, W. Pedrycz, "Evaluation on fuzzy linear regression models," Fuzzy Sets and Systems, 1991, vol. 39, pp. 51 - 63.
- [8] Y.-H.O. Chang, "Synthesize fuzzy-random data by hybrid fuzzy least-squares regression analysis", J. National Kaohsiung Inst. Technol., 1997, vol. 28, pp. 1-14.
- [9] Y.-H.O. Chang, "Hybrid fuzzy-random analysis for system modeling", J. National Kaohsiung Inst. Technol., 1998, vol. 29, pp. 1-9.
- [10] Y.-H.O. Chang, "Hybrid fuzzy least-squares regression analysis and its reliability measures", Fuzzy Sets and Systems, 2001, vol. 119, pp. 225-246.
- [11] Y.-H.O. Chang, B.M. Ayyub, "Fuzzy regression methods – a comparative assessment", Fuzzy Sets and Systems, 2001, vol. 119, pp. 187-203.

- [12] R.J. Hathaway, J.C. Bezdek, "Switching regression models and fuzzy clustering", IEEE Transactions on fuzzy systems, vol. 1, № 3, pp. 195-203, 1993.
- [13] I.B. Turksen, "Fuzzy functions with LSE", Applied Soft Computing, vol. 8, № 3, pp. 1178-1188, 2008.
- [14] A. Celikyilmaz, I.B. Turksen, "Fuzzy functions with support vector machines", Information Sciences, 2007, vol. 177, pp. 5163-5177.
- [15] C.C. Yao, P.T. Yu, "Fuzzy regression based on asymmetric support vector machines", Applied Mathematics and Computation, 2006, 182, pp. 175-193
- [16] P.-T. Chang, E.S. Lee, "Fuzzy linear regression with spreads unrestricted in sign", Comput. Math. Appl., 1994, 28, pp. 61-71.
- [17] C.B. Cheng, E.S. Lee, Fuzzy regression with radial basis function network", Fuzzy Sets and Systems, 2001, vol. 119, pp. 291-301.
- [18] C.C. Chuang, "Fuzzy weighted support vector regression with a fuzzy partition", IEEE Trans. on SMC Part B (37), pp. 630-640, 2007.
- [19] H. Ishibuchi, "Fuzzy regression analysis", J. Fuzzy Theory and Systems, 1992, 4, pp. 137-148.
- [20] H. Ishibuchi, M. Nii, "Fuzzy regression using asymmetric fuzzy coefficients and fuzzified neural networks", Fuzzy Sets and Systems, 2001, vol. 119, pp. 273-290.
- [21] O. M. Poleshuk, E. G. Komarov, "Multiple hybrid regression for fuzzy observed data" Proceedings of the 27th International Conference of the North American Fuzzy Information Processing Society, NAFIPS'2008, - New York, New York, May 19-22, 2008.
- [22] O.Poleshchuk, E.Komarov, "Hybrid fuzzy least-squares regression model for qualitative characteristics", Advances in Intelligent and Soft Computing., 2010, vol. 68, pp. 187-196.
- [23] O. M. Poleshuk, E. G. Komarov, "A nonlinear hybrid fuzzy least-squares regression model" Proceedings of the 30th International Conference of the North American Fuzzy Information Processing Society, NAFIPS'2011, - El Paso, Texas, March 18-20, 2011.
- [24] O.Poleshchuk, E.Komarov "A fuzzy linear regression model for interval type-2 fuzzy sets" Proceedings of the 31th International Conference of the North American Fuzzy Information Processing Society, NAFIPS'2012, - San Francisco, August 6-8, 2012.
- [25] F. Liu and J. M. Mendel, "Encoding words into interval Type-2 fuzzy sets using an interval approach", IEEE Trans. Fuzzy Systems, vol. 16, № 6, 2008.
- [26] O.M. Poleshuk, E.G. Komarov, "New defuzzification method based on weighted intervals", Proceedings of the 27th International Conference of the North American Fuzzy Information Processing Society, NAFIPS'2008, New York, New York, May 19-22, 2008.
- [27] Olga Poleshchuk and Evgeniy Komarov Expert Fuzzy Information Processing. – Springer-Verlag Berlin Heidelberg, 2011. – 237 pp.
- [28] T. F. Coleman, Y. Li, "A reflective newton method for minimizing a quadratic function subject to bounds on some of the variables", SIAM J. Optim, vol. 6, pp. 1040-1058, 1996.