

Stress Intensity Factor for Dynamic Cracking of Composite Material by X-FEM Method

S. Lecheb, A. Nour, A. Chellil, H. Mechakra, N. Hamad, H. Kebir

Abstract—The work involves develops attended by a numerical execution of the eXtend Finite Element Method premises a measurement by the fracture process cracked so many cracked plates an application will be processed for the calculation of the stress intensity factor SIF. In the first we give in statically part the distribution of stress, displacement field and strain of composite plate in two cases uncrack/edge crack, also in dynamical part the first six modes shape. Secondly, we calculate Stress Intensity Factor SIF for different orientation angle θ of central crack with length ($2a=0.4\text{mm}$) in plan strain condition, KI and KII are obtained for mode I and mode II respectively using X-FEM method. Finally from crack inclined involving mixed modes results, the comparison we chose dangerous inclination and the best crack angle when K is minimal.

Keywords—Stress Intensity Factor (SIF), Crack orientation, Glass/Epoxy, natural Frequencies, X-FEM.

I. INTRODUCTION

THE innovative idea to enrich the field edge near the FEA method [1]-[3], the basic principles of the division of the FEA method and the extended finite element method X-FEM unit were developed twenty years later by [4]. In under a decade, X-FEM has become the major thorough search for solving a variety of problems of discontinuity. Components calculated with cracking are now reinterpreted using the method of sharp discontinuities or extended finite element method X-FEM based upon the concept of partition of the unit [5]. Enhance the cinematic of the continuum; such techniques can introduce discontinuities in the field of displacement with the aid of a relatively limited number DOF. The main advantage here is that the grid does not require conforming to the geometry of the crack. Overall, these methods necessitate another meshing of the point of the crack that modifies component of the problem. As well, packaging problems persist. Finally, the X-FEM approach representing properly the singular solution to the crack tip and highly simplifies the product selection meshing and another meshing method of standard finite elements. Consequently based of these advantages is suggested to address this method (X-FEM). The first one actual quality interpreting fatigue and fracture mechanics is presented 1920 by Griffith [6]. Irwin [7] has provided than the stress and displacement near of the crack-tip can be described using one parameter associated with the rate

of energy release G . This parameter resulting from the linear fracture mechanics is called the stress intensity factor (SIF). The concept of (SIF) has also been used by Paris [8] to describe the cracks growth by substituting the concept of toughness by the notion of fatigue forecasts of superior quality of the service life of components. The period between 1960 and 1980 saw an intensification of research into the break with two competing schools. On the one hand the supporters of the approach using linear fracture mechanics and those interested primarily in lamination developed at the end of a crack on the other. To account for the effect of stratification on the fields of stresses and displacements of the slot end, several authors as Irwin 1962 [7], later, in 1968 H. Rice et al. [9] developed a novel parameter known as J integral to better describe the distribution of stresses in plastic zones. Reference [10] also offered a method of use them not only to describe the complete tenacity, as well as to connect to the flaw size and in the area of applied constraints, and made the link among J integral and CTOD. In close proximity of the front, are stress singularity at $(1/r)$ and the peculiarity is characterized by using the stress intensity (K_I , K_{II}) Irwin factors defined by [7]. SIF characterize the strength of the peculiarity of the stress field at the crack tip. About Extended Finite Element Method X-FEM, from the way the crack is unknown a priori mixed-mode, developed by computer simulations will be carried using the extended finite element method X-FEM where the cracks are not disclosed expressly by the mesh. This method is based on a mesh partition [11]. Benefits of this method for computer simulation of the dynamic rupture were subject numerous publications. It was used for sequentially the 2D crack growth [12]. The procedure is here developed for the vibrant crack growth in the work [13]. The first applications of X-FEM for composites have been reported by [14]-[16] thinner stratified composites simulated and found that the isotropic enriching office can not represent the asymptotic solution for a crack in an orthotropic material. The newest work is reported by [17] on the propagation of cracks in general orthotropic composites. They debated the impact of enrichment tip cracks and different types of interaction integral factors in identify intensity stress combination mode. The development of crack-tip enrichment office orthotropic has been reported in a number of documents by [18]-[19]. They have developed three function types of wealth for the different classes of composite.

S. Lecheb is with the Laboratory of Engines Dynamics and Vibroacoustics, University of Boumerdes, Algeria (e-mail: samir_lecheb@yahoo.fr).

A. Nour and A. Chellil are with the Laboratory of Engines Dynamics and Vibroacoustics, University of Boumerdes, Algeria.

H. Kebir is with the Laboratory Roberval, University of Technology Compiègne, UTC, France.

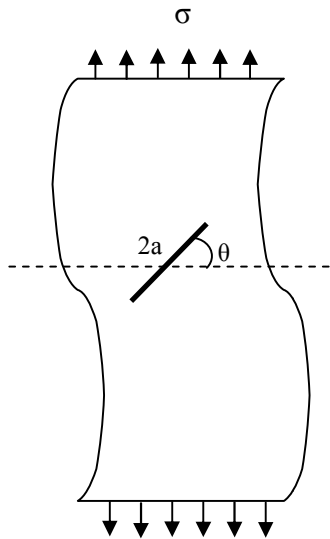

Fig. 1 Inclined Central crack in infinite composite plate

II. MODEL OF PLAT

In this part of work we will see the numerical simulation of composite material plate by Abaqus software which can give the distribution of stress, strain and displacement field of composite plate, material properties of this plat gives:

- 2 value of young modulus: $E_1= 38600\text{MPa}$ $E_2= 8270\text{MPa}$
- 3 value of shear modulus: $G_{12}= 4140\text{MPa}$ $G_{23}= 4140\text{MPa}$ $G_{13}=4140\text{MPa}$
- Poisson ratio: $\nu_{12}=0.26$
- Density: 2.56Kg/m^3

We create composite lamina with 2 ply with deferent's angles of fibers ($0^\circ/90^\circ$) in the progress of simulation we make deferent's numbers of ply with orientation of fibers.

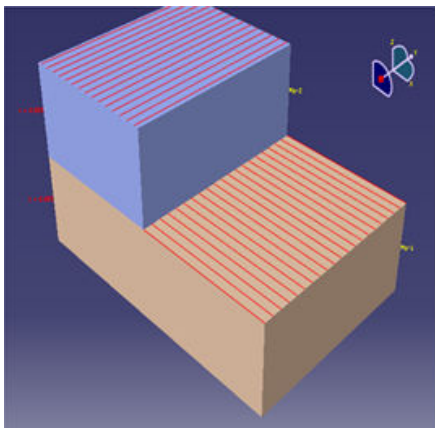

Fig. 2 Modeling of plate and create composite laminate

We make our boundary condition is this case we take into account for the displacement which are $U_1= U_2= U_3= UR_1= UR_2= UR_3= 0$ and we applied tensile.

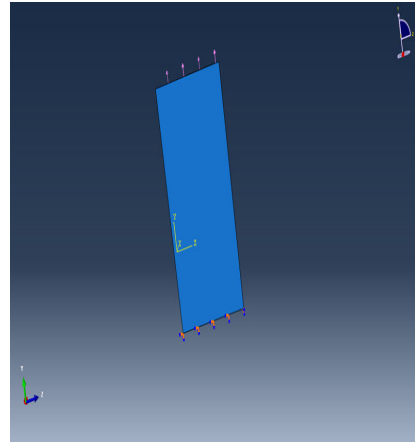

Fig. 3 Load and boundary condition of specimen

A. Stress

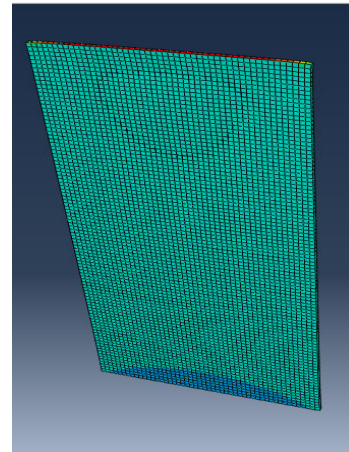

Fig. 4 Maximum stress of Von Misses $S_{\max}=1.057 \text{ e}+02\text{Mpa}$

B. Strain

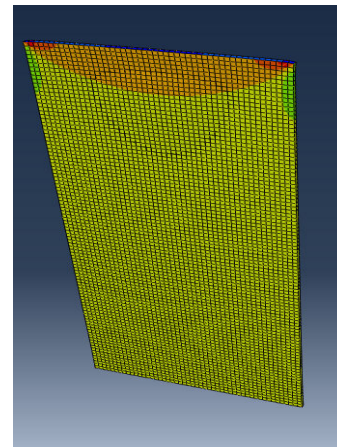

Fig. 5 Maximum strain $E_{\max}=4.829 \text{ e}-03$

C. Displacement

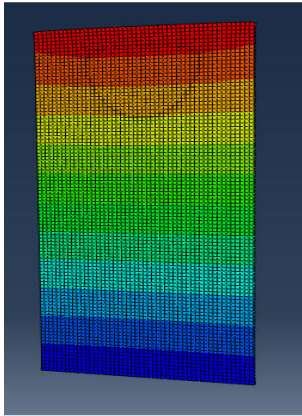

Fig. 6 Maximum displacement $U_{\max} = 2.186 \text{ e-}01\text{mm}$

D. Modes Shapes

The figures below shown the first six natural frequencies with displacements

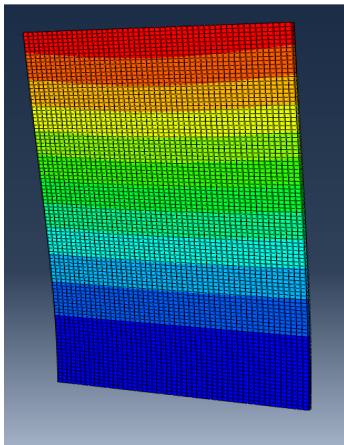

Fig. 7 First Mode shape bending $U_{\max}=1\text{mm}$, $f_1=0.96156 \text{ HZ}$

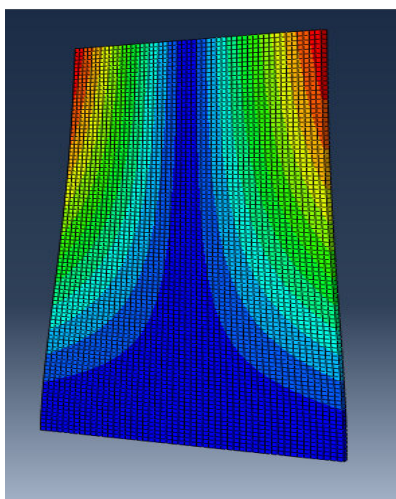

Fig. 8 Second Mode shape torque $U_{\max}= 1\text{mm}$, $f_2=6.0403\text{HZ}$

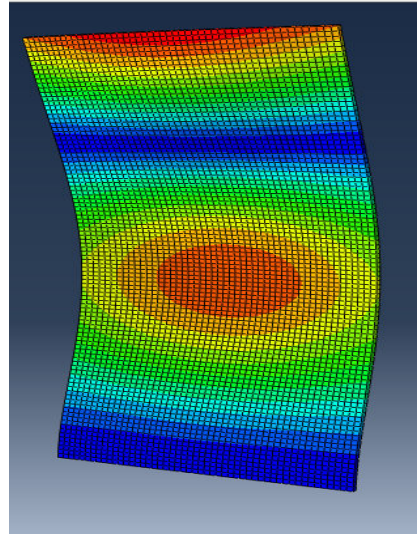

Fig. 9 Third Mode shape $U_{\max}= 1\text{mm}$, $f_3=8.6226 \text{ HZ}$

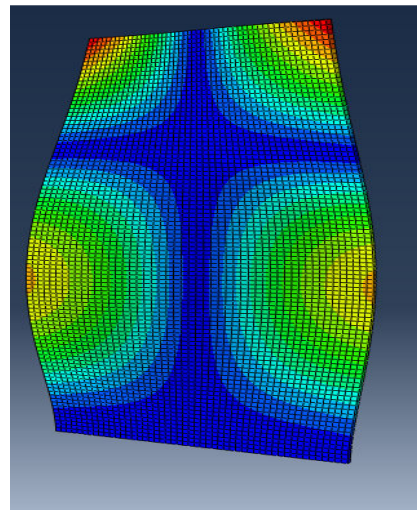

Fig. 10 Fourth Mode shape $U_{\max}=1\text{mm}$, $f_4=17.002 \text{ HZ}$

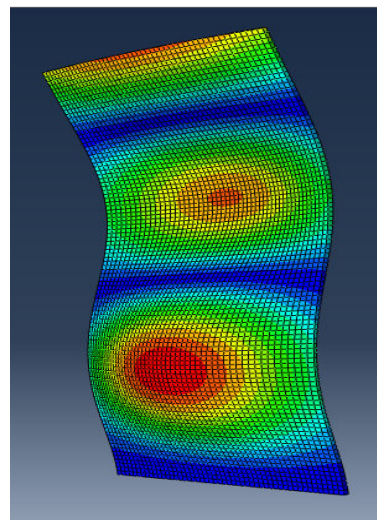

Fig. 11 Fifth Mode shape $U_{\max}= 1\text{mm}$ $f_5= 19.705 \text{ HZ}$

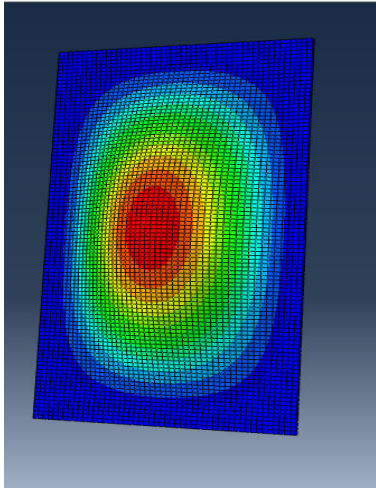

Fig. 12 Sixth Modes shape $U_{max}=1mm$, $f_0=26.501$ HZ

TABLE I
 SIX FIRST NATURAL FREQUENCIES OF UNCRACK PLATE

F1 (Hz)	F2 (Hz)	F3 (Hz)	F4 (Hz)	F5 (Hz)	F6 (Hz)
0.96	6.04	8.62	17.00	19.70	26.50

III. EDGE CRACK INITIATION

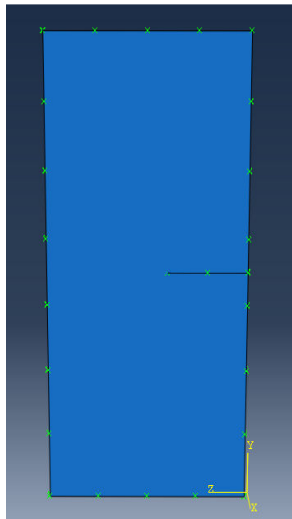

Fig. 13 Crack initiation in plate composite

We will do the same manipulation with the same boundary condition.

Stress:

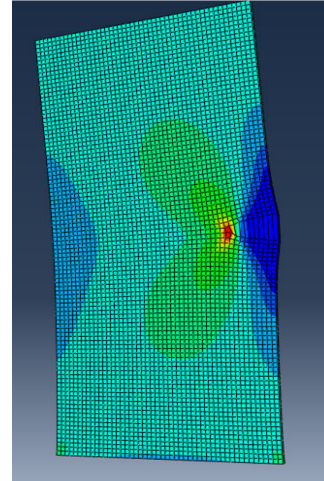

Fig. 14 Von Misses stress for cracked plate $S_{max}= 1.180E+02$ MPa

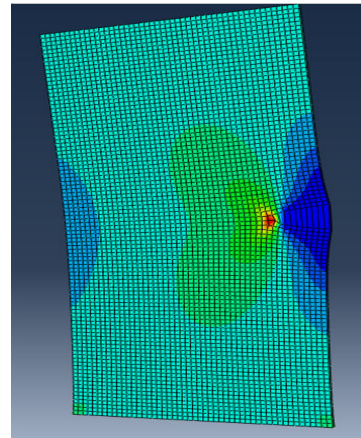

Fig. 15 Maximum Stress in the X direction by XFEM method (max $S_{11}=63.23MPa$)

We have concentration of stress in the level crack tip.
 Displacement:

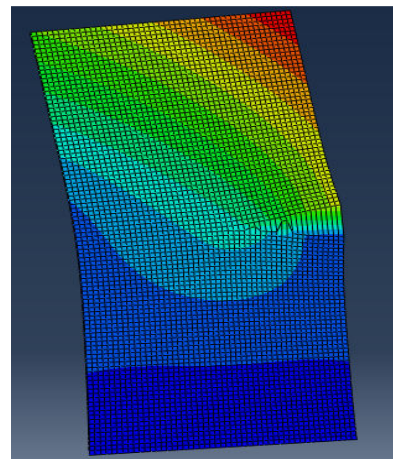

Fig. 16 Maximum displacement by XFEM method $U_{max} = 3.088 e-01mm$

Finding of the table above that the displacement max augments and the stress takes a very important increase because we have concentration of stress at crack-tip.

TABLE II
 COMPARISON OF MAXIMUM DISPLACEMENT AND STRESS WITHOUT AND WITH CRACK

	Stress (MPa)	Max displacement (mm)
Plate without crack	105.7	0.218
Plate with crack	118.0	3.088

IV. CENTRAL CRACK INITIATION

A rectangular plate of dimension 0.5 x 01 under uniform tension= 100 pa over its width has an inclined angle to the perpendicular to the direction of pull of crack length 2a= 0.4mm. From [15], [19]:

$$\begin{aligned} K_I &= \sigma \cos^2 \theta \sqrt{2\pi a} \\ K_{II} &= \sigma \cos \theta \sin \theta \sqrt{2\pi a} \end{aligned} \quad (1)$$

Physically, these formulas mean that K is a maximum if the crack is perpendicular to it and the bias decreases to be zero when the crack s aligns therewith when the mode II is for a maximum angle of 45 No and no to 0 ° or 90 °.

To calculate K_I and K_{II} of mixed modes known equations are applied following:

$$\begin{aligned} K_I &= \sigma_{11} \cos^2 \theta \sqrt{2\pi r} \\ K_{II} &= \sigma_{11} \cos \theta \sin \theta \sqrt{2\pi r} \end{aligned} \quad (2)$$

σ_{11} : Nodal solution of the stress field was obtained by Abaqus by XFEM.

r: the distance between the crack tip and enrichment singular nodes was obtained by Abaqus.

The procedure for calculating k_I and k_{II} is done by taking the values in Abaqus's and apply the equation.

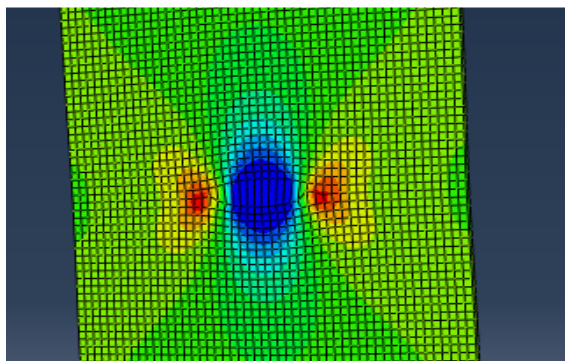

Fig. 17 Crack inclined angle 0°

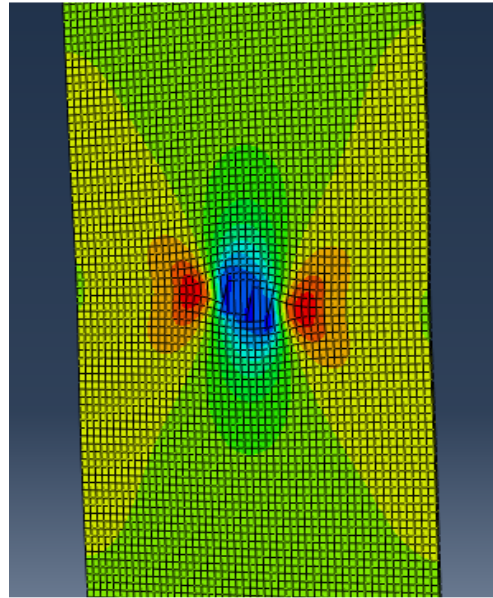

Fig. 18 Crack inclined angle 15°

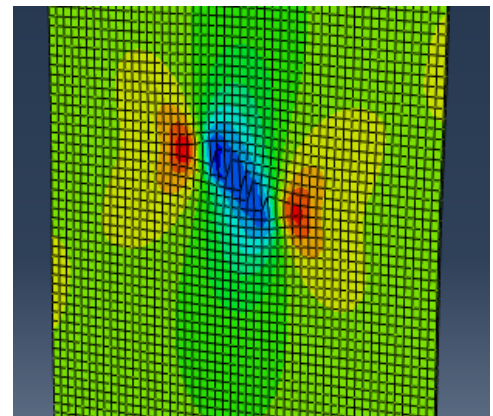

Fig. 19 Crack inclined angle 30°

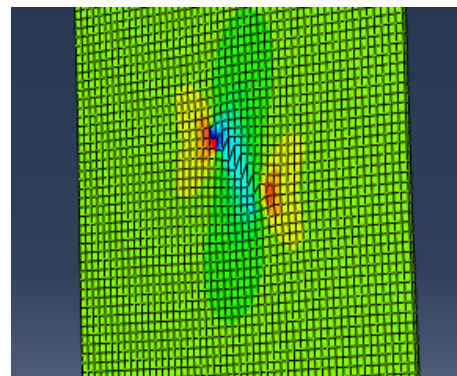

Fig. 20 Crack inclined angle 45°

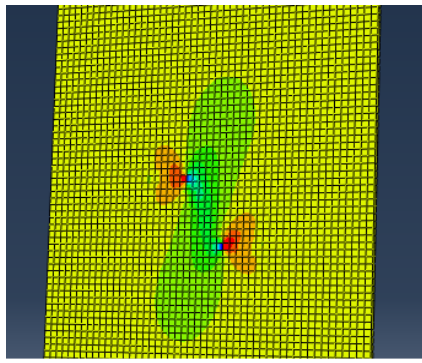

Fig. 21 Crack inclined angle 60°

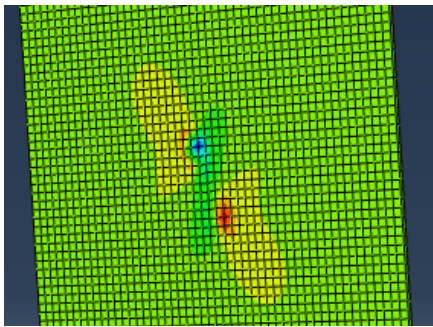

Fig. 22 Crack inclined angle 75°

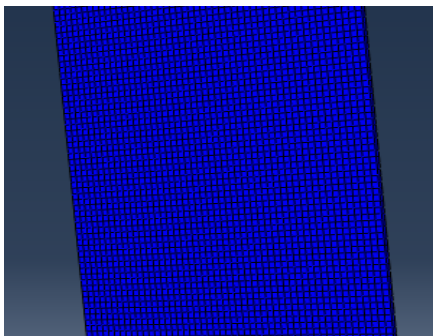

Fig. 23 Crack inclined angle 90°

TABLE III
 KI AND KII AS A FUNCTION OF THE INCLINATION ANGLE

θ	K_I MPa \sqrt{m}	K_{II} MPa \sqrt{m}
0°	9.34	0
15°	8.32	2.25
30°	7.57	4.37
45°	3.91	3.91
60°	3.23	6.17
75°	0.64	2.32
90°	0	0

The values of K_I , K_{II} y are given in:
 We notice that $K_I=K_{II}$ for $\{\theta=45^\circ$ and $\theta=90^\circ\}$

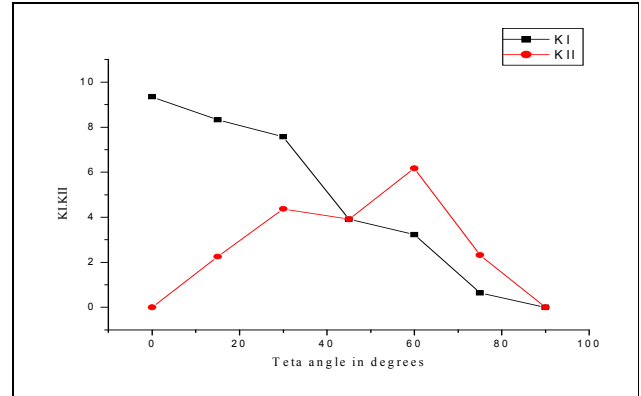

Fig. 24 KI and KII based on the driven plate and an inclined crack centered

$K_I > K_{II}$ for $0^\circ < \theta < 45^\circ$, $K_I > K_{II}$ for $45^\circ < \theta < 90^\circ$ and $K_I = K_{II}$ for $(\theta = 45^\circ, \theta = 90^\circ)$

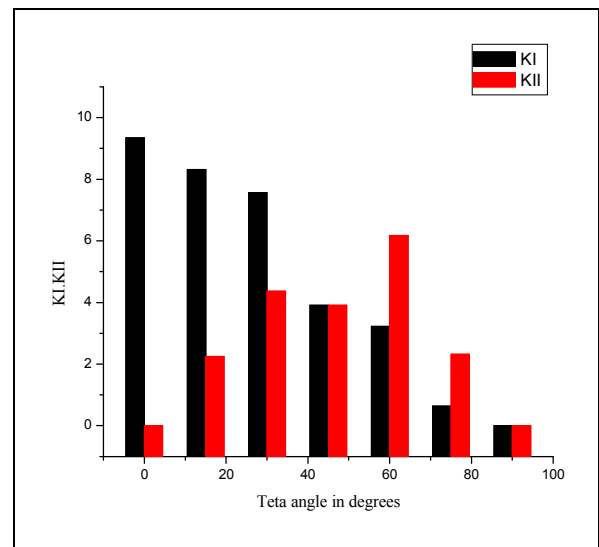

Fig. 25 KI and KII based on the driven plate and an inclined crack central

K_I decreases with the increase of the angle θ , the K_{II} increases to 60° and then decreases.

Assessing SIF mixed modes by XFEM infinite plate with a crack centered and tilted, we can calculate K_I and K_{II} . The results in Table showed the efficiency XFEM. Indeed, the functions of singular and discontinuous enrichment provide a significant advantage in the calculation accuracy of XFEM.

V. CONCLUSION

This study calculates the local and analyzing materials by the XFEM method, particularly composites cracked with deferent angles. Calculation and evaluation of the stress intensity factor SIF in different configurations and mixed modes (I and II) are also studied. The results show that a concentration of stress at the edge crack in the level crack tip. The displacement max augments and the stress takes a very important increase because we have singularity point of stress at crack-tip. K is the minimum angle for $\theta = 90^\circ$ crack.

REFERENCES

- [1] Benzley, S.E. (1974) Representation of singularities with isoparametric finite elements. *International Journal for Numerical Methods in Engineering*, 8, 537–545.
- [2] Atluri, S.N., Kobayashi, A.S. and Nakagaki, M. (1975b) An assumed displacement hybrid finite element model for linear fracture mechanics. *International Journal of Fracture*, 11(2), 257–271.
- [3] Gifford, N.L. and Hilton, P.D. (1978) Stress intensity factors by enriched finite elements. *Engineering Fracture Mechanics*, 20, 485–296.
- [4] Belytschko, T. and Black, T. (1999) Elastic crack growth in finite elements with minimal remeshing. *International Journal of Fracture Mechanics*, 45, 601–620.
- [5] Moes, N., Gravouil, A. and Belytschko, T. (2002) Non-planar 3D crack growth by the extended finite element and level sets–Part I: Mechanical model. *International Journal for Numerical Methods in Engineering*, 53, 2549–2568.
- [6] Griffith A.A. The Phenomena of Rupture and Flow in Solids. *Philosophical Transactions of the Royal Society of London* 1920, Vol. A-221:163-198.
- [7] Irwin, GR. Analysis of stresses and strains near the end of a crack traversing a plate. *Journal of Applied Mechanics* 1957. 24: 361-364.
- [8] Erdogan F, Paris P. A critical analysis of crack propagation laws 1963. *Journal of Basic Engineering*, Transaction of the American Society of Mechanical Engineers. p 528-534.
- [9] Rice, JR. Plane strain deformation near a crack tip in a power law hardening material. *Journal of the Mechanics and Physics of Solids* 1968. vol.16: 1-12.
- [10] Erdogan F and Civelek M. B. Crack problems for a rectangular sheet and infinite strip. *International Journal of Fracture* 1982. 19:139-159.
- [11] Babuska I, Melenk J. The partition of unity method. *International Journal for Numerical Methods in Engineering* 1997. Vol. 40:727–758.
- [12] Prabel, B., Marie, S. and Combescure, A. (2007) Using the X-FEM method to model the dynamic propagation and arrest of cleavage cracks in ferritic steel. *Engineering Fracture Mechanics*, 75(10), 2984–3009.
- [13] Soheil Mohammadi. 2012 . *XFEM Fracture Analysis of Composites*, First Edition. John Wiley & Sons, Ltd. Published 2012 by John Wiley & Sons, Ltd.
- [14] Dolbow, J.E. and Nadeau, J.C. (2002) On the use of effective properties for the fracture analysis of microstructured materials. *Engineering Fracture Mechanics*, 69, 1607–1634.
- [15] Wells, and Barst. (2003) The condition of fast fracture in aluminium alloys with particular reference to comet failures. *British Welding Research Association Report*.
- [16] Nagashima, T. and Suemasu, H. (2006) Stress analysis of composite laminates with delamination using XFEM. *International Journal of Computational Methods*, 3, 521–543.
- [17] Bayesteh, H. and Mohammadi, S. (2012) Fracture analysis of orthotropic functionally graded materials by XFEM. *Journal of Composites, Part B*.
- [18] Asadpoure, A., Mohammadi, S. and Vafai, A. (2006) Modeling crack in orthotropic media using a coupled finite element and partition of unity methods. *Finite Elements in Analysis and Design*, 42(13), 1165–1175.
- [19] Asadpoure, A. and Mohammadi, S. (2007) A new approach to simulate the crack with the extended finite element method in orthotropic media. *International Journal for Numerical Methods in Engineering*, 69, 2150–2172.