

3D Numerical Studies on External Aerodynamics of a Flying Car

Sasitharan Ambicapathy, J. Vignesh, P. Sivaraj, Godfrey Derek Sams, K. Sabarinath, V. R. Sanal Kumar

Abstract—The external flow simulation of a flying car at take off phase is a daunting task owing to the fact that the prediction of the transient unsteady flow features during its deployment phase is very complex. In this paper 3D numerical simulations of external flow of Ferrari F430 proposed flying car with different NACA 9618 rectangular wings have been carried. Additionally, the aerodynamics characteristics have been generated for optimizing its geometry for achieving the minimum take off velocity with better overall performance in both road and air. The three-dimensional standard k-omega turbulence model has been used for capturing the intrinsic flow physics during the take off phase. In the numerical study, a fully implicit finite volume scheme of the compressible, Reynolds-Averaged, Navier-Stokes equations is employed. Through the detailed parametric analytical studies we have conjectured that Ferrari F430 flying car facilitated with high wings having three different deployment histories during the take off phase is the best choice for accomplishing its better performance for the commercial applications.

Keywords—Aerodynamics of flying car, air taxi, negative lift, roadable airplane.

I. INTRODUCTION

THE modern flying car concepts like the Terrafugia Transition are showing remarkable promise. The Terrafugia Transition is a light sport, roadable airplane under development by Terrafugia since 2006 [1]-[3]. Although flying car concept has been around since the early days of motoring, the optimized aerodynamic design of a flying car is still a daunting task [1]-[15]. Of late the concept of Godfrey. D. S. et al. [1] on the design of Ferrari F430 flying car got reasonable attention in the industry. The authors reported that Ferrari F430 flying car with thrust to weight ratio 0.3176 will take off at 53 km/hr with the help of NACA 9618 airfoil shaped wings deployed in both sides. It is well known that the existing flying car designs are expensive and additionally the previous studies reveal that more efforts must be put for the realization of a commercial flying car. The literature review reveals that the designers have been trying to build a flying car for a century, but only a few designs ever succeeded in flying

through the air and driving on the road. The literature review further reveals that more efforts must be put for the realization of a lucrative design of a flying car. Since the integration of computational fluid dynamics (CFD) methods into a wide range of engineering disciplines is rising sharply, mainly due to the positive trends in computational power and affordability, one can use it in the flying car design lucratively. Note that the aerodynamics design of a flying car is more complex than high performance race car and a conventional aircraft owing to the fact that prediction of the transient unsteady flow features during the deployment of flying car wings and further its take off phase is very complex.

The designer of a flying car has the major concern on the creation of upward force (lift) with low takeoff velocity, with minimum drag, coupled with better stability and control warranting its overall high performance both in road and air. Note that the amount of upward force created by the flying car is depending primarily on two things; viz., the shape, including surface area, aspect ratio and cross-section of the device, and the device's orientation (or angle of attack). This paper is a continuation of the work of Godfrey. D. S. et al. [1]. In this connected paper authors made several attempts to make Ferrari F430 car to fly with lower take-off velocity by using cascading of wings for escaping from the occasional traffic congestions. Fig. 1 shows the physical model and the Mach number contours of the Ferrari F430 flying car proposed by Godfrey. D. S. et al., [1]. The authors successfully carried out 3D CFD analyses using a k-omega turbulence model. Although CFD is now widely used in automobile and aerospace industry, archival reports on flying cars are less than abundant. In this paper 3D numerical studies on external flow features of a Ferrari F430 car with different wing positions and deployment history are reported. Note that validated CFD results can be used as a preliminary design tool or to complement experimental methods.

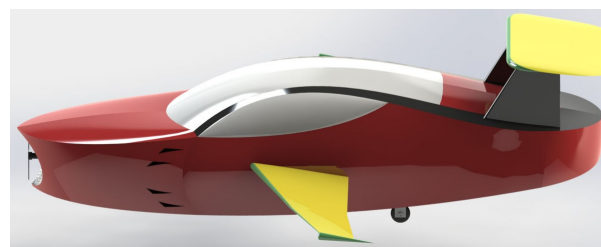

(a) Ferrari F430 proposed flying car

Sasitharan Ambicapathy, Vignesh J, Sivaraj P, and Godfrey Derek Sams are with Kumaraguru College of Technology, Coimbatore – 641 049, Tamil Nadu, India, (e-mail: ambi.sasitharan@gmail.com, vigneshj91@gmail.com, ariensiva@gmail.com, godfreyrocz@gmail.com)

Sabarinath K was with Kumaraguru College of Technology, India, and currently with Department of Aerospace Engineering, University of Cranfield, UK, (e-mail: s.karunakaran@cranfield.ac.uk)

V. R. Sanal Kumar is currently with Department of Aeronautical Engineering, Kumaraguru College of Technology, Coimbatore – 641 049, Tamil Nadu, India; (Corresponding Author, phone: +91 – 938 867 9565; fax: +91-422-266 9406; email: vr_sanalkumar@yahoo.co.in).

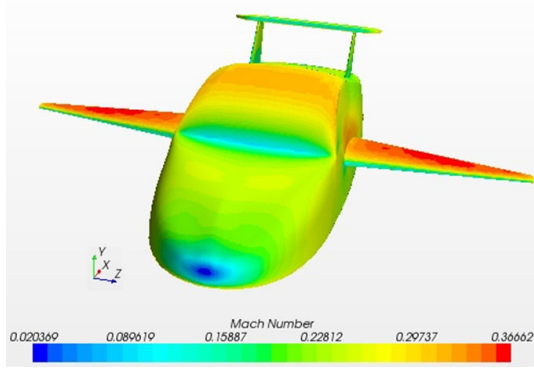

(b) Mach number contours of Ferrari F430 flying car

Fig. 1 (a), (b) Demonstration of the proposed Ferrari F430 flying car (Adopted from Godfrey et al. [1])

II. NUMERICAL METHOD OF SOLUTION

Numerical simulations have been carried out with the help of a three-dimensional standard k-omega turbulence model. This turbulence model is an empirical model based on model transport equations for the turbulence kinetic energy and a specific dissipation rate. This code solves standard k-omega turbulence equations with shear flow corrections using a coupled second order implicit unsteady formulation. In the numerical study, a fully implicit finite volume scheme of the compressible, Reynolds-Averaged, Navier-Stokes equations is employed. Initial wall temperature, inlet total pressure and temperature are specified. Ideal gas is selected as the working fluid. The code has successfully validated with the help of benchmark solutions. The wing is designed with a NACA series of 9618 airfoil due to its better aerodynamic characteristics. The total cell count of Ferrari F430 flying car base model is around 1,60,000.

Fig. 2 shows the idealized 3D symmetrical model (right half) of Ferrari F430 (base model) reference car. Figs. 3-9 show different physical models of Ferrari F430 flying car fixed with different types of wings for examining its external flow features. Figs. 4 (a)-(c) show Ferrari F430 flying car with high wing having three different deployment histories. The base wing can be fixed or retractable. This design was proposed for meeting the road width dimensional constraints. Note that at the time of taxiing, Ferrari F430 is having only base wings with an acceptable width of the road. Further at the time of takeoff first deployment of both side wings will take place and later during the climb and cruise condition second deployment will take place.

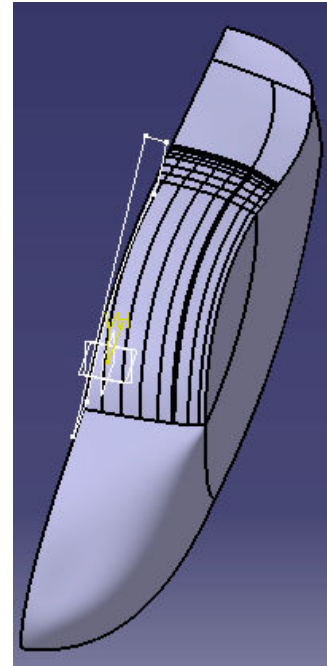

Fig. 2 The 3D base model (right half) of Ferrari F430

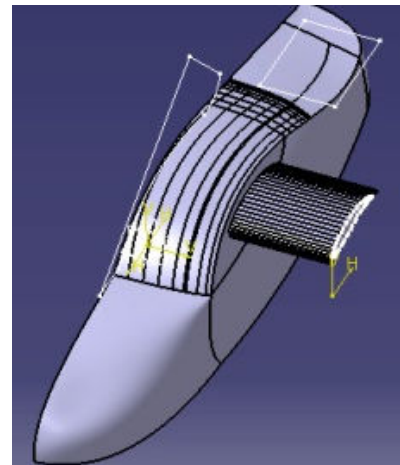
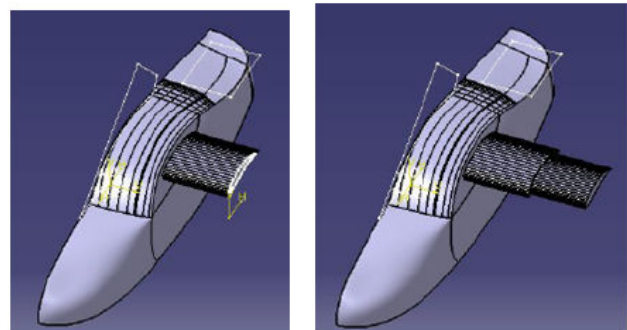
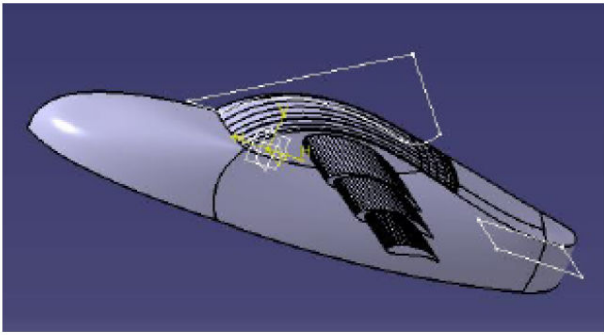

Fig. 3 Ferrari F430 flying car with high wing (Case-1)



(a) Base wing

(b) Base wing with first extension



(c) Takeoff position after the second extension of the wing

Fig. 4 (a)-(c) Ferrari F430 flying car with high wing having different deployment histories (Case-2)

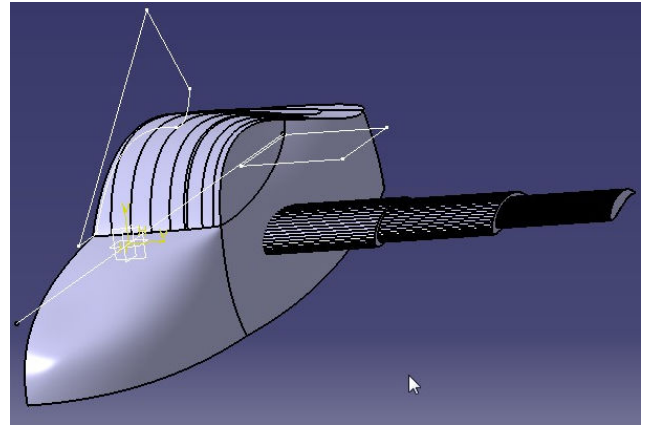

Fig. 8 Ferrari F430 flying car with mid wings having three different deployment histories (Case-6)

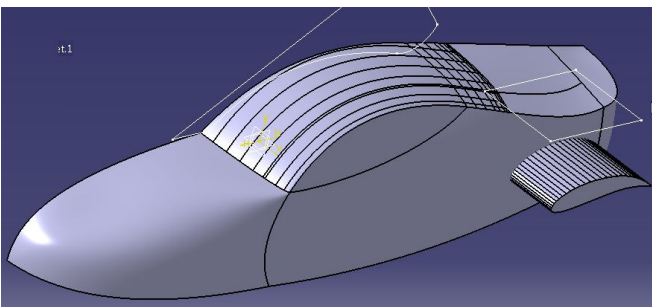

Fig. 5 Ferrari F430 flying car with wing near to the rear end (Case-3)

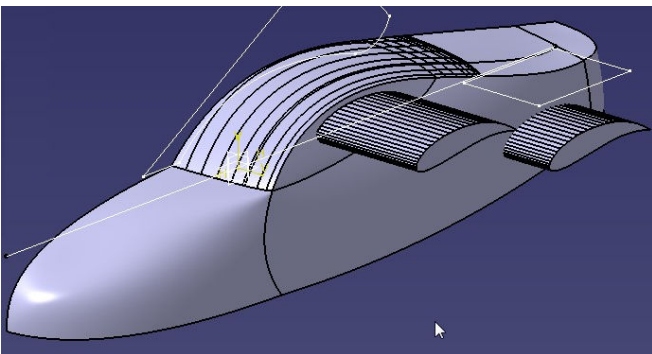

Fig. 6 Ferrari F430 flying car having both high and rear end wings (Case-4)

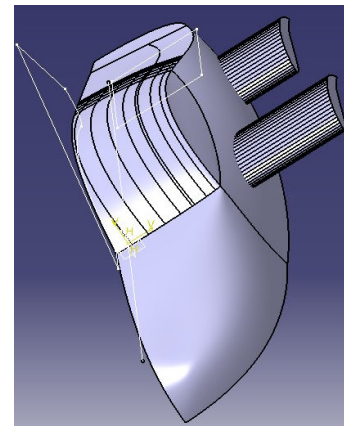

Fig. 9 Ferrari F430 flying car having both mid and rear end wings (Case-7)

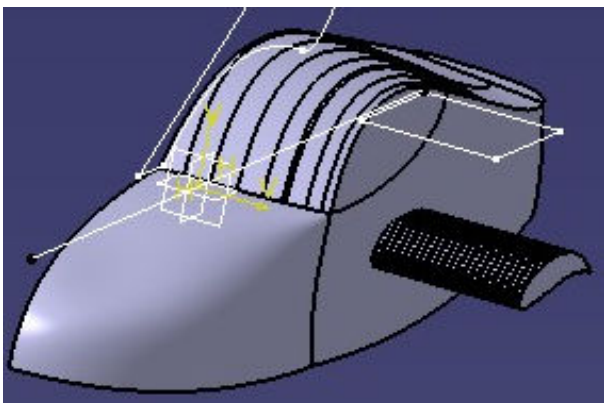

Fig. 7 Ferrari F430 flying car with mid wing (Case-5)

III. RESULTS AND DISCUSSION

The design of a commercial flying car must be in line with the present road scenario. Therefore, selection of the dimensions of the wing is one of the major constraints of any flying car designer. Admittedly, fixing big wings to the roadable car can easily generate desirable lift at desirable take off velocity for its flying. But optimum design of a flying car for both road taxiing and air taxiing is a daunting task. Due to the dimensional constraints of roads, in this paper authors have made several attempts for creating desirable lift at minimum take off velocity with different wing positions and angles of attack. After detailed parametric analytical studies we observed that a case (Case-2) with deployable high wing, as seen in Figs. 4 (a)-(c), can meet the road dimensional constraints and can produce desirable lift at low take off velocity. In this paper several case studies have been carried out with high wing, mid wing and rear wing for evaluating the take-off velocity of Ferrari F430 car with NACA 9618 rectangular wing. Figs 10 (a)-(c) show the contours of static pressure at various speeds of Ferrari F430 car (right half). Grid for this model has been generated after a detailed grid refinement exercises. The grids are clustered near to the wall and suitable CFL number has been chosen though out the

computation. The results are verified through the benchmark solutions. Table I shows the aerodynamics characteristics of Ferrari F430 car without wing. It is evident from Table I that without wing Ferrari F430 cannot take off at a free stream velocity of 45 m/s due to the negative lift coefficient, warranting better road performance.

TABLE I
 AERODYNAMIC CHARACTERISTICS OF FERRARI F430 CAR (BASE MODEL)

Velocity	C_L	C_D
15 m/s	-0.32159	0.334296
30 m/s	-0.29422	0.318038
45 m/s	-0.28424	0.312268

C_L – Lift Coefficient C_d – Drag Coefficient

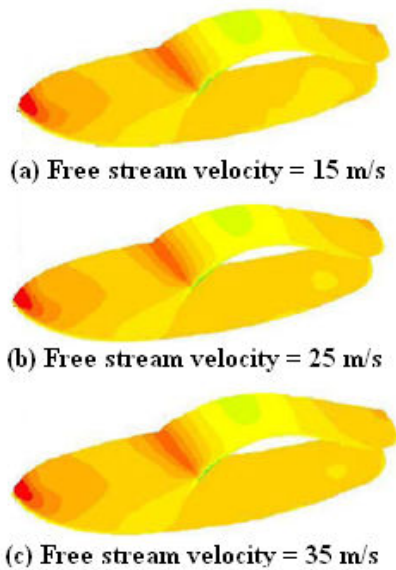
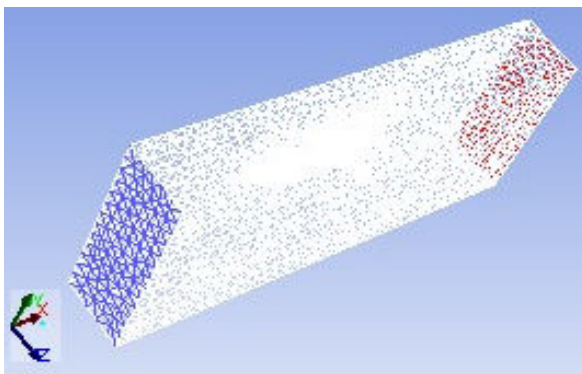
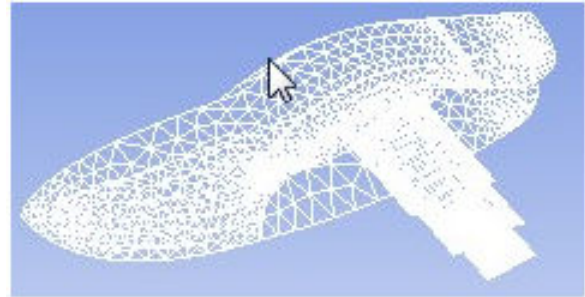

Fig. 10 (a)-(c) Contours of static pressure at various speeds of Ferrari F430 reference car



(a) Full computational domain.



(b) Grid model of Ferrari F430 flying car (Case-2)

Fig. 11 (a-b) Grid system in the computational domain

As stated in the introduction, in this paper the principle that allows a car to rise off the ground by creating lift using additional wings. The primary components of a flying car can be used to create upward force when the car is travelling at take off velocity. This can be achieved by streamlining the car body, and the use of suitable wings. The rounded and tapered shape of the top of the car is designed to slice through the air and minimize wind resistance. In this paper authors have made several attempts to create lift higher than the weight of the car by fixing the rectangular NACA 9816 wing at different positions on the body with different angles of attack. Figs. 11 (a), (b) show the grid system in the computational domain. The numerical results generated for various cases are presented in Figs. 12-16.

Airfoils are recognized as lifting surface objects and a particular criterion called performance parameter is defined for them. This parameter is the ratio of lift-to-drag of the airfoil. Since these objects move in viscous fluid, a particular flow regime with low thickness and larger velocity gradient is formed around them, which is identified as boundary layer. This flow regime causes several changes in behavior of the airfoils such as the inception point of the transition phenomenon, the starting point of flow separation, and the boundary layer thickness. For capturing this intrinsic flow physics the aerodynamic characteristics of the flying car with NACA 9618 wing at different angles of attack at different velocities have been evaluated in viscous flows and reported in Tables II-VIII.

Analyses reveal that at the given range of free steam velocity Ferrari F430 flying car with different geometrical options considered in this study will generate upward force. However analyses further reveal that at these free stream velocities Ferrari F430 car with deployable NACA 9618 rectangular wings (case-2) can generate lift higher than the weight of the flying car at the lower take off velocity, warranting low taxiing distance during traffic congestion.

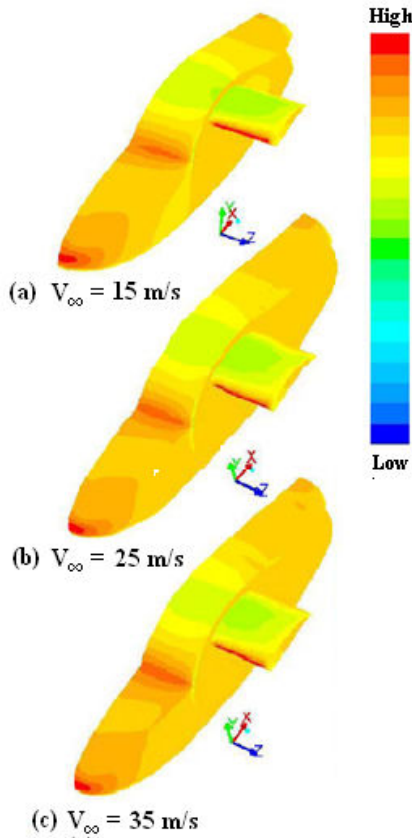

Fig. 12 (a)-(c) Contours of the static pressure at various speeds of Ferrari F430 flying car with short high wing model

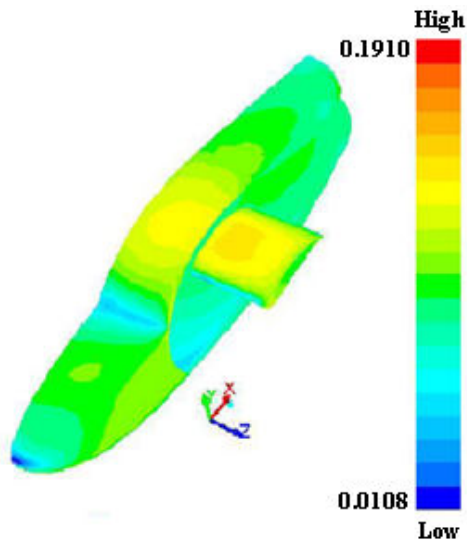

Fig. 13 Contours of Mach number at a free stream velocity of 35 m/s of Ferrari F430 flying car with short high wing model

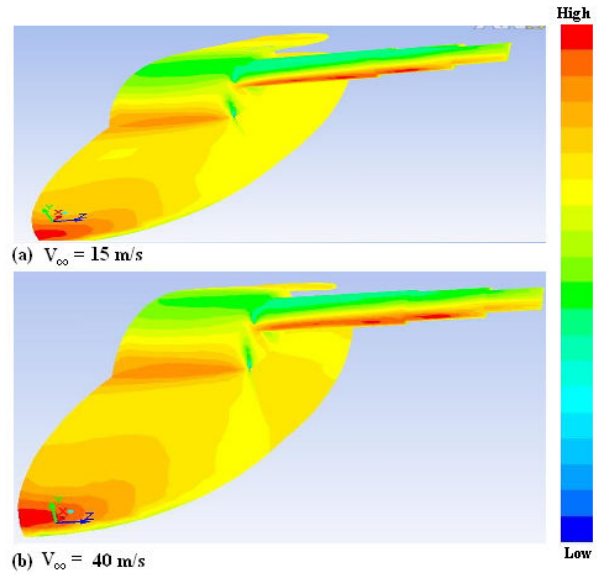

Fig. 14 (a)-(b) Contours of the static pressure at two different speeds of Ferrari F430 flying car with long (extendable) high wings

Table I shows the aerodynamic characteristics of Ferrari F430 car at three different speeds. It is evident from the numerical results generated through parametric analytical studies that up to 45 m/s Ferrari car produce negative lift. But Tables II-VIII show that Ferrari F430 car can be converted in to a flying car well before reaching the free stream velocity of 45 m/s with the corresponding wings. We have observed that among the seven physical models of Ferrari F430 flying car, considered in this study, a case of long high wing with three different deployment histories (Case-2) is the best flying car for commercial applications. Figs. 14 (a), (b) show the contours of static pressure at two different speeds of the aforesaid model of Ferrari F430 flying car with high extendable wings. Figs. 15-17 are corroborating that Case-2 is the best flying car option for getting better aerodynamic efficiency.

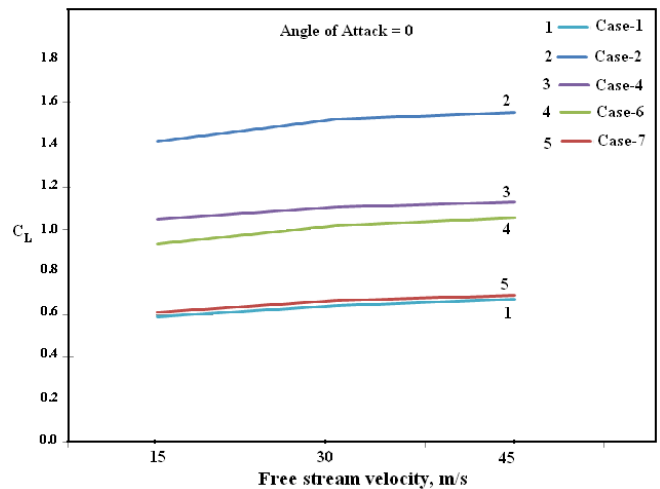

Fig. 15 Comparison of C_L variations for different flying car models at different velocities at zero angle of attack

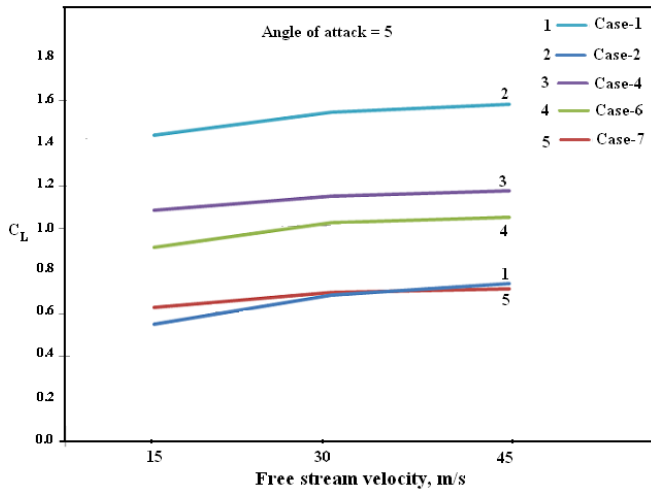

Fig. 16 Comparison of C_L variations for different flying car models at different velocities at an angle of attack of five

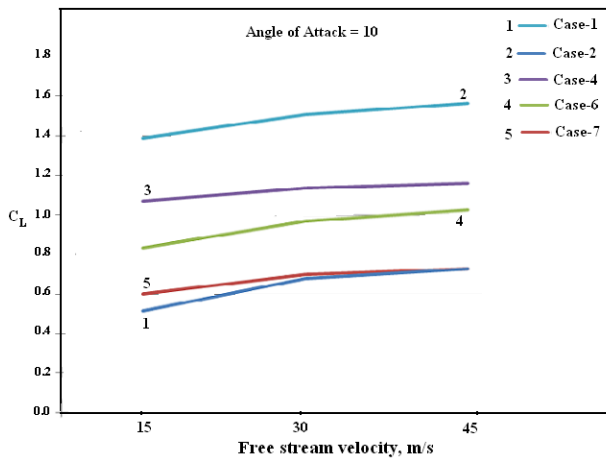

Fig. 17 Comparison of C_L variations for different flying car models at different velocities at an angle of attack of ten

TABLE II
AERODYNAMIC CHARACTERISTICS OF FERRARI F430 FLYING CAR (CASE-1)

V	AoA = 0		AoA = 5		AoA = 10	
	C_L	C_D	C_L	C_D	C_L	C_D
15 m/s	0.591342	0.501152	0.543714	0.503776	0.515916	0.496604
30 m/s	0.643786	0.472916	0.678393	0.485323	0.679274	0.485019
45 m/s	0.673725	0.4583	0.73027	0.483259	0.729097	0.448591

V-Velocity, AoA-Angle of Attack, C_L -Lift Coefficient, C_D -Drag Coefficient.

TABLE III
AERODYNAMIC CHARACTERISTICS OF FERRARI F430 FLYING CAR (CASE-2)

V	AoA = 0		AoA = 5		AoA = 10	
	C_L	C_D	C_L	C_D	C_L	C_D
15 m/s	1.4148661	0.56931906	1.419630	0.573794	1.389823	0.576236
30 m/s	1.5191091	0.53600213	1.525492	0.549478	1.509404	0.542711
45 m/s	1.552219	0.53030393	1.565314	0.530713	1.568809	0.549890

V-Velocity, AoA-Angle of Attack, C_L -Lift Coefficient, C_D -Drag Coefficient.

TABLE IV
AERODYNAMIC CHARACTERISTICS OF FERRARI F430 FLYING CAR (CASE-3)

V	AoA = 0		AoA = 5		AoA = 10	
	C_L	C_D	C_L	C_D	C_L	C_D
15 m/s	0.188866	0.418414	0.194559	0.412738	0.17284	0.398857
30 m/s	0.220425	0.396399	0.267831	0.396057	0.278367	0.40007
45 m/s	0.257569	0.385901	0.287629	0.381799	0.295697	0.370281

V-Velocity, AoA-Angle of Attack, C_L -Lift Coefficient, C_D -Drag Coefficient.

TABLE V
AERODYNAMIC CHARACTERISTICS OF FERRARI F430 FLYING CAR (CASE-4)

V	AoA = 0		AoA = 5		AoA = 10	
	C_L	C_D	C_L	C_D	C_L	C_D
15 m/s	1.049693	0.561152	1.07176	0.562124	1.059179	0.55731
30 m/s	1.106441	0.537064	1.137165	0.547106	1.14011	0.542625
45 m/s	1.13085	0.533458	1.1623	0.529877	1.181761	0.543542

V-Velocity, AoA-Angle of Attack, C_L -Lift Coefficient, C_D -Drag Coefficient.

TABLE VI
AERODYNAMIC CHARACTERISTICS OF FERRARI F430 FLYING CAR (CASE-5)

V	AoA = 0		AoA = 5		AoA = 10	
	C_L	C_D	C_L	C_D	C_L	C_D
15 m/s	0.613128	0.540738	0.620713	0.541608	0.599016	0.538362
30 m/s	0.666163	0.518743	0.691823	0.524213	0.697401	0.521947
45 m/s	0.689381	0.512194	0.707888	0.509476	0.727898	0.518327

V-Velocity, AoA-Angle of Attack, C_L -Lift Coefficient, C_D -Drag Coefficient.

TABLE VII
AERODYNAMIC CHARACTERISTICS OF FERRARI F430 FLYING CAR (CASE-6)

V	AoA = 0		AoA = 5		AoA = 10	
	C_L	C_D	C_L	C_D	C_L	C_D
15 m/s	0.932935	0.546917	0.901326	0.548907	0.833179	0.547809
30 m/s	1.020041	0.515027	1.012353	0.522616	0.968134	0.512653
45 m/s	1.054759	0.50595	1.038988	0.505903	1.028403	0.517948

V-Velocity, AoA-Angle of Attack, C_L -Lift Coefficient, C_D -Drag Coefficient.

TABLE VIII
AERODYNAMIC CHARACTERISTICS OF FERRARI F430 FLYING CAR (CASE-7)

V	AoA = 0		AoA = 5		AoA = 10	
	C_L	C_D	C_L	C_D	C_L	C_D
15 m/s	0.311829	0.4680322	0.314031	0.466983	0.279028	0.46388
30 m/s	0.361834	0.4414857	0.368874	0.447814	0.359085	0.434274
45 m/s	0.381496	0.4332071	0.385492	0.430581	0.401705	0.440808

V-Velocity, AoA-Angle of Attack, C_L -Lift Coefficient, C_D -Drag Coefficient.

TABLE IX
TAKE OFF VELOCITY OF FERRARI F430 FLYING CAR

CASE	TAKE OFF VELOCITY (Km/hr)
Case-1	56
Case-2	36
Case-4	42
Case-6	43
Case-7	53

We have observed that Ferrari F430 model generated negative lift coefficient at given velocities. But the same model with NACA 9618 wing generated positive lift, which was sufficient for its take off from the road at the given

velocity. In this paper detailed analyses of external flow features and the corresponding aerodynamics characteristics of various flying car options have been carried out in detail at various flying conditions, orientations and wing positions. Among the cases considered in this study we have observed that a case with long high deployable wing will generate lift higher than the weight of the flying car for its take off at a lower take off velocity. Effort has been taken for estimating the take off velocities of various models of Ferrari F430 flying car. We have observed that lowest take off velocity is obtained as 36 Km/hr for a case with deployable wing (Case-2). Table IX shows the comparison of take off velocities of various successful models of flying car considered in this study.

IV. CONCLUDING REMARKS

We observed that the Ferrari F430 flying car with high extendable NACA 9618 rectangular wing will take off at 36 km/hr. Through the detailed parametric analytical studies we have concluded that Ferrari F430 flying car with long high wing facilitating three different deployment histories during the take off phase is the best choice for its commercial applications.

ACKNOWLEDGMENT

The authors would like to thank the management of Kumaraguru College of Technology, India for their extensive support for completing this research work.

REFERENCES

- [1] Godfrey Derek Sams, Kamali Gurunathan, and Prasanth Selvan, V.R. Sanal Kumar "Conceptual Design and Analysis of Ferrari F430 Flying Car", with proceedings of "International Journal of Research in Engineering and Technology (IJRET)" Vol. 1, No. 6, 2012 ISSN 2277 – 4378.
- [2] Godfrey Derek Sams, Kamali Gurunathan, and Prasanth Selvan, V.R. Sanal Kumar "Conceptual Design and Analysis of Ferrari F430 Flying Car", International Conference on Aerospace, Automotive and Mechanical Engineering (ICAAME'2012), Planetary Scientific and Research Center, Pattaya, Thailand, December 8-9, 2012.
- [3] Page, Lewis, "Terrafugia flying car gets road-safety exemptions", *The Register*, 4 July 2011; retrieved 11 July 2011.
- [4] Wolf-Heinrich Hucho, Chapter 1 - Introduction to automobile aerodynamics, *Aerodynamics of Road Vehicles, 1987, Pages 1-46*.
- [5] McBeath, S., *Competition Car Aerodynamics: A Practical Handbook*, Haynes Publishing, ISBN 978-1844252305, 2006.
- [6] WU Dawei, WU Zheng, ZhANG Landing, HU Jizhong, Safety and Airworthiness Design of Ultra-Light and Very Light Amphibious Aircrafts, The 2nd International Symposium on Aircraft Airworthiness (ISAA 2011), *Procedia Engineering* 17 (2011) 212 – 225.
- [7] Haines, Thomas B. (19 March 2009). "First roadable airplane takes flight". *Aircraft Owners and Pilots Association (AOPA)*. Retrieved 2009-03-19.
- [8] Chien-Hsiung Tsai, Lung-Ming Fu, Chang-Hsien Tai, Yen-Loung Huang, Jik-Chang Leong, Computational aero-acoustic analysis of a passenger car with a rear spoiler, *Applied Mathematical Modelling, Volume 33, Issue 9, September 2009, Pages 3661-3673*.
- [9] K.R. Cooper, Bluff-body aerodynamics as applied to vehicles, *Journal of Wind Engineering and Industrial Aerodynamics, Volume 49, Issues 1-3, December 1993, Pages 1-21*.
- [10] Durbin, Dee-Ann (2012-04-02). "Flying car gets closer to reality with test flight". *boston.com*. Associated Press. Retrieved April 20, 2012.
- [11] Mone, Gregory (2008-10). "The Driving Airplane Gets Real". *Popular Science*: pp. 42–48. Retrieved 2009-03-20.

- [12] Phillips, Matt (March 18, 2009). "Flying Car Takes First Flight". *The Middle Seat Terminal* (The Wall St. Journal). Retrieved 2009-03-19.
- [13] Welsh, Jonathan (April 5, 2012). "Flying Car Maker Offers 'Show Special' Discount". *Driver's Seat*. Wall St. Journal. Retrieved 2012-07-30.
- [14] Terrafugia's Transition street-legal airplane continues flight and drive testing". Terrafugia. Retrieved 30 July 2012.
- [15] Ryan, David L. (2009-03-18). "'Flying car' at the Museum of Science". Boston.com (The Boston Globe). Retrieved 2009-03-28.