

# ZigBee Wireless Sensor Nodes with Hybrid Energy Storage System Based On Li-ion Battery and Solar Energy Supply

Chia-Chi Chang, Chuan-Bi Lin, Chia-Min Chan

**Abstract**—Most ZigBee sensor networks to date make use of nodes with limited processing, communication, and energy capabilities. Energy consumption is of great importance in wireless sensor applications as their nodes are commonly battery-driven. Once ZigBee nodes are deployed outdoors, limited power may make a sensor network useless before its purpose is complete. At present, there are two strategies for long node and network lifetime. The first strategy is saving energy as much as possible. The energy consumption will be minimized through switching the node from active mode to sleep mode and routing protocol with ultra-low energy consumption. The second strategy is to evaluate the energy consumption of sensor applications as accurately as possible. Erroneous energy model may render a ZigBee sensor network useless before changing batteries.

In this paper, we present a ZigBee wireless sensor node with four key modules: a processing and radio unit, an energy harvesting unit, an energy storage unit, and a sensor unit. The processing unit uses CC2530 for controlling the sensor, carrying out routing protocol, and performing wireless communication with other nodes. The harvesting unit uses a 2W solar panel to provide lasting energy for the node. The storage unit consists of a rechargeable 1200 mAh Li-ion battery and a battery charger using a constant-current/constant-voltage algorithm. Our solution to extend node lifetime is implemented. Finally, a long-term sensor network test is used to exhibit the functionality of the solar powered system.

**Keywords**—ZigBee, Li-ion battery, solar panel, CC2530.

## I. INTRODUCTION

WIRELESS Sensor Networks may consist of hundreds or even thousands of nodes which highly integrate ultra-low power embedded system technology, wireless communication technology, and sensor technology [5],[9]. The sensor nodes are usually able to perform real-time monitoring, collect data about monitored variables of an area, and transmit sensing data to the sink over the wireless link. It is generally accepted that wireless sensor networks provide unique opportunities in environmental monitoring, health care, and safe precaution applications. Outdoor environmental monitoring is considered as a significant driver for ZigBee [11] sensor network research today. However, most outdoor sensor nodes are commonly battery driven. Their lifetime is highly dependent on their energy conservation.

Chia-Chi Chang and Chuan-Bi Lin are with the Department of Information and Communication Engineering, Chaoyang University of Technology, Taichung, Taiwan (e-mail: ccchang@cyut.edu.tw, cblin@cyut.edu.tw).

Chia-Min Chan is a college student. He now studies at Chaoyang University of Technology, Taichung Taiwan (e-mail: s9930077@cyut.edu.tw).

Energy consumption is prime concern in restricting the lifetime of the ZigBee sensor nodes and networks [6], [7]. The limited lifetime may render a sensor network useless before its purpose is fulfilled. In general, there are two main strategies in enhancing the overall lifetime of a sensor network. The first one is that sensor nodes periodically switch on and off their components to conserve energy, such as the radio, the microcontroller, or peripheral sensors. Besides, the duty-cycling radio protocols running on real sensor hardware are able to extend the lifetime of the sensor network. The second is to estimate the energy model of the sensor node as precisely as possible. Erroneous energy estimation may cause wrong battery replacement after the nodes ran out energy. At present, energy-efficiency is considered as one of the prime research for wireless sensor networks today.

The paper presents a ZigBee node based on a hybrid energy storage system consisting of a Li-ion battery and a solar energy power supply. Our node structure uses the Texas Instruments CC2530 with 256 KB of flash memory and 8 KB of RAM [1]. The CC2530 combines an IEEE 802.15.4 [3], [4]-compliant radio transceiver with a single-cycle 8051-compatible core. The node can obtain energy from sunlight and store energy to the Li-ion battery. In this way, the energy supply system can achieve self-management and the lifetime of node and networks can be unlimited.

The remainder of this paper is organized as follows. Section II presents an overview of our ZigBee hardware implementation. We discuss the design of our hybrid energy storage system in Section III. In Section IV, the result is demonstrated by wirelessly monitoring system voltages during a long-term test. Section V concludes the paper.

## II. ZIGBEE HARDWARE SYSTEM OVERVIEW

The architecture of our ZigBee sensor node is shown in Fig. 1. The system is composed of four key modules: a processing and radio unit, and energy harvesting unit, an energy storage unit, and a sensor unit.

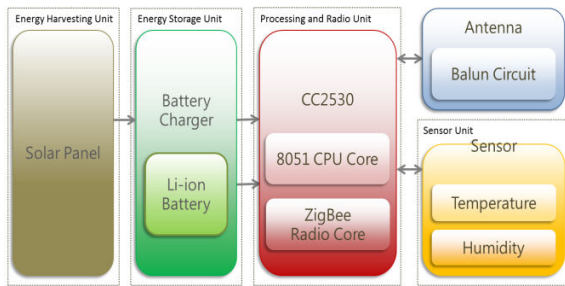

Fig. 1 ZigBee sensor node overview

#### A. Processing and Radio Unit

The proposed ZigBee node in this paper uses CC2530 made by Texas Instruments as the processing and radio unit. The CC2530 combines an IEEE 802.15.4 compliant radio transceiver with an 8051 CPU Core. The key features of the CC2530 are shown as follows:

##### RF

- 2.4 GHz IEEE 802.15.4 RF Transceiver
- Programmable Output Power Up to 4.5 dBm

##### Microcontroller

- 8-bit CISC CPU with Code Prefetch
- 256-KB ISP Flash, 8-KB RAM with Retention in All Power Modes
- Wake-up from Power mode 1 is less than 4 $\mu$ s.

##### Peripherals

- Powerful Five-Channel DMA
- IEEE 802.15.4 MAC Timer, Three General-Purpose Timers
- CSMA/CA Hardware Support
- 12-bit ADC with Eight Channels and Configurable Resolution
- Two USARTs with Support for SPI and UART.

##### Low Power

- Active-Mode RX(CPU Idle): 24 mA
- Active-Mode TX at 1 dBm (CPU Idle): 29 mA
- Power Mode 1: 0.2 mA
- Power Mode 2: 1  $\mu$ A
- Power Mode 3: 0.4  $\mu$ A
- Wide Supply-Voltage Range (2 V-3.6 V)

We selected the SD form factor as the basis for the processing and radio unit. It can be soldered directly to support hardware as shown in Fig. 2. This unit is responsible for controlling the sensor, processing the sensing data, and forwarding radio packets to the base station.

The processing and radio unit uses the ESMT F25L016A [2] serial code flash for external data and code storage. Besides, the external flash may be used for robust over-the-air programming for remote code updates. The flash holds 2 MB of data and is decomposed into 32 blocks, each 64 KB in size. The flash shares SPI communication lines with the CC2530.



Fig. 2 Front of the processing and radio unit

#### B. Energy Harvesting Unit

In order to provide lasting energy for the node, the energy harvesting unit transforms solar energy into electric energy. In this way, the energy is collected by the solar panel and stored in the energy storage unit. However, the solar panel depends on the environmental conditions such as sun irradiation, cloud coverage, and shading. The solar panel specifications are given in Table I.

TABLE I  
MONO-CRYSTALLINE SOLAR PANEL SPECIFICATIONS

Parameter	Value	Unit
Voltage at peak power	5.5	V
Current at peak power	360	mA
Typical peak power	2	W
Efficiency	16	%
Length	180	mm
Width	81	mm
Depth	1.5	mm

In our outdoor WSN, each node can be powered by one 3.7 V Li-ion battery with capacity of 1200 mAh or one solar panel. The two energy supplies are parallel-connected to provide the inherent robustness, compared to the series connection. The output of the solar panel will be fed to a linear charger IC, which can provide charge current to the battery and regulate the final float voltage to 4.2 V.

#### C. Energy Storage Unit

The energy generated by the solar panel will vary dramatically with the ambient lighting conditions. Therefore, an energy storage unit composing of a Li-ion battery is needed to provide continuous energy when the ambient light is no longer available. The Li-ion battery provides a high-density platform, especially at night or in poor weather conditions when the solar power is not available. The energy storage unit consists of a 1200 mAh rechargeable Li-ion battery and a complete constant-current/constant-voltage linear charger. The linear charger IC must not pull too much current from the solar panel as it will collapse its internal voltage. Besides, the linear charger must be efficient over a very wide range of charging currents and require the minimum level of quiescent current while the node is asleep in order to extend the life of the whole WSN network. High quiescent currents in the energy storage

unit can severely limit the amount of energy supply that can be made available to the node load. The energy supply system can achieve self-management, the wireless nodes can supply

energy permanently and the use of whole network can unlimited.

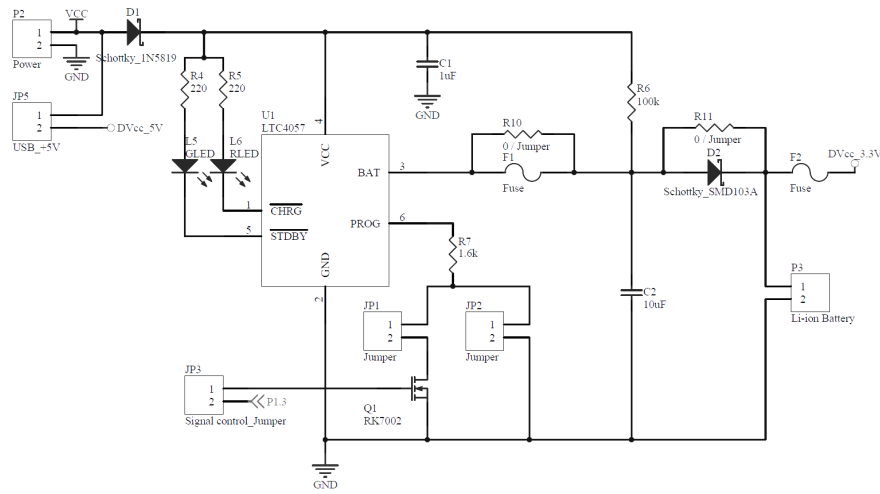

Fig. 3 A simplified representation of the solar-powered battery charger using a TP4057 of schematic

#### D. Sensor Unit

The node sensors can be miscellaneous. The sensor unit in this paper incorporates a digital humidity and temperature sensor, SHT11, made by Sensirion Company [8]. The SHT11 provides 14-bit temperature measurements and 12-bit humidity measurements. For high speed or extreme low power applications, the default measurement resolution of 14-bit (temperature) and 12-bit (humidity) can be reduced to 12 and 8 bit through the status register. The SHT11 communicates with the processing and radio unit through a two-wire serial interface and that interface is not identical to the I<sup>2</sup>C conform interface. The two-wire interface uses only two bi-directional bus lines, one for clock (SCL) and one for data (DATA). The SCK is used to synchronize the communication between the CC2530 and the SHT11. The DATA pin is used to transfer data in and out of the SHT11. It has a wide operating voltage range between 2.4 and 5.5V and its supply current is only 550µA.

### III. HYBRID ENERGY SYSTEM DESIGN

The solar energy is transferred from the solar panel to the Li-ion battery using a linear charger, TP4057 [10]. The TP4057 made by Nanjing Top Power Corporation is a constant-current/constant-voltage linear charger for single cell Li-ion rechargeable batteries. The linear charger includes an internal P-channel power MOSFET and thermal regulation circuitry. No blocking diode or external current sense resistor is required; therefore, few external components are required for the operation of the TP4057. The typical circuitry of TP4057 is shown in Fig. 3.

The hybrid energy system allows charging from both an energy harvesting unit (P2) and a USB port (JP5). The CHRG pin can drive a red LED to indicate that a charge cycle is in progress, and the STDBY pin can drive a green LED to indicate that the Li-ion battery is full charge. The charge current is

programmed using a single resistor (R7) from the PROG pin to ground. The program resistor and the charge current are calculated using the following equation:

$$R_{PROG} = \frac{1000}{I_{BAT}} \times (1.3 - I_{BAT}), \text{ if } I_{BAT} > 0.3A \quad (1)$$

Using  $R_{PROG} = 1.6K\Omega$ , we can calculate the charge current to be:

$$I_{BAT} = 500 \text{ mA} \quad (2)$$

At any point in the charge cycle, the hybrid energy system can be put into shutdown mode by removing  $R_{PROG}$  thus floating the PROG pin. Once the charge cycle terminates, the N-channel MOSFET (Q1) connected to the resistor R7 will be used to float the PROG pin. This reduces the battery drain current to less than 2µA and the supply current to less than 50 µA. Nearly all of the power consumption is generated by the internal MOSFET. The power consumption of the energy storage unit is given by:

$$P_C = (V_{CC} - V_{BAT}) \times I_{BAT} \quad (3)$$

where  $P_C$  is the power consumption,  $V_{CC}$  is the input supply voltage,  $V_{BAT}$  is the battery voltage and  $I_{BAT}$  is the charge current. The energy storage unit operating from a 5 V energy harvesting unit is programmed to supply 500 mA current to a discharged Li-ion battery with a voltage of 4.2 V. The power consumption of the energy storage unit is approximately 400 mW.

### IV. EXPERIMENTAL RESULTS

The implementation of the ZigBee sensor node with hybrid energy storage system is shown in Fig. 4. The efficiency measurements were done in the lab environment, while the long-term test was run outdoors in the presence of natural light.

In this section, the nodes were deployed in a rectangular area with dimensions 10 times 10 meters. In order to verify the operation of the developed energy storage scheme, one of nodes is chosen to record the sensing data during the experiment, and other nodes are chosen to forward radio packets to the base station.



Fig. 4 Photo of the ZigBee sensor node with hybrid energy storage system

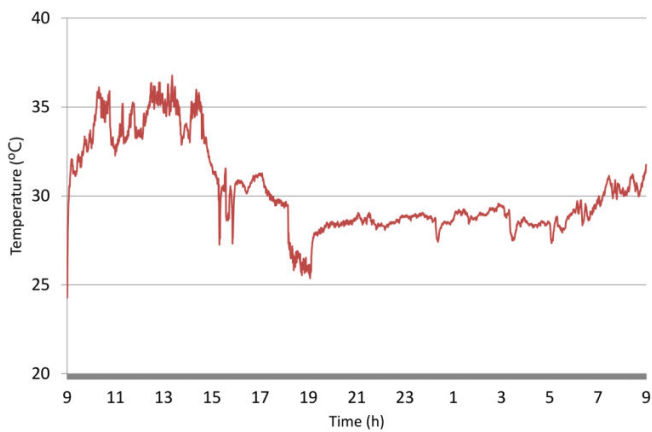

(a)



(b)

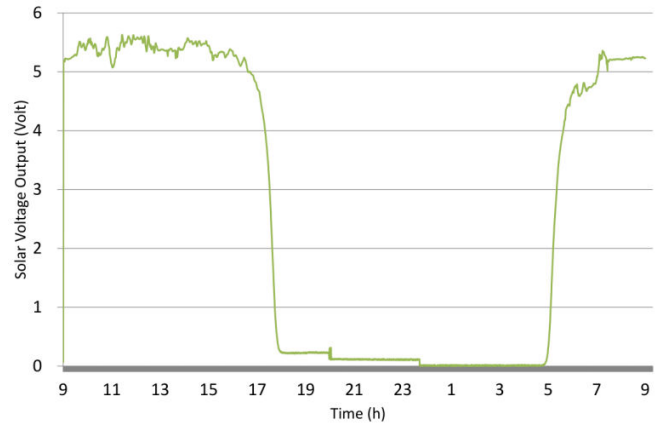

(c)

Fig. 5 (a) On-board temperature sensor data, (b) humidity sensor data, and (c) the voltage output of the solar panel for a one day test

All nodes were left to run autonomously for 24 hours, starting from 9:15 am on day 1, and finishing at 9:15 am on day 2. The ration packets with temperature, humidity, and solar energy information stored in the base station are illustrated in Figs. 5 (a)-(c). In Fig. 5 (a), the temperature in the daytime is higher than in the evening. We also measure the highest temperature at midday. The sensing readings are also clearly shown that the ZigBee sensor node can remain operation during night-time.

## V. CONCLUSION

A wireless sensor node usually consists of some kind of sensors, ultralow power microcontroller, wireless transceiver, and analog-to-digital converter. The nodes are commonly battery driven, and energy is a limited resource for the sensor nodes. As battery-operated nodes are deployed in the outdoors, it is challenging and sometimes even impossible to change batteries, when nodes run out of energy. Therefore, limited energy resource may cause a sensor network useless before its purpose is reached. Nowadays, there are two ways to extend long node and network lifetime. The first one is saving energy as much as possible. In general, sleep modes should be used as much as possible, and the sleep mode should be selected so that as few as possible of the node's functions are operating. In particular, the processing unit, the radio unit, and sensors may need special consideration when trying to achieve the lowest possible energy consumption. The second is to evaluate the energy consumption of sensor applications as accurately as possible. A precise and detailed low-level energy model of the sensor node can determine how much energy the components spend in different processing states. It can help users to improve their implementation and so to extend node and network lifetime.

In this paper, we present an energy management scheme for a hybrid storage system consisting of an energy harvesting unit and an energy storage unit. Our developed ZigBee node consists of a processing and radio unit, an energy harvesting unit, an energy storage unit, and a sensor unit. As the energy generated by the energy harvesting unit will vary dramatically

with the ambient lighting conditions, an energy storage unit can provide continuous energy for the night-mode operation or when the output power of the energy harvesting unit is too low. A constant-current/constant-voltage linear charger, TP4057, simplifies the task of managing energy between the energy harvesting unit and the energy storage unit. In this way, the energy supply system can provide lasting energy for the ZigBee sensor node, and the node can supply electricity permanently. The lifetime of the node and network can be unlimited. Finally, the long-term test ran outdoors in the presence of the ambient light used to exhibit the functionality of the solar powered system.

#### ACKNOWLEDGMENT

We would like to thank the National Science Council of the Republic of China (Taiwan) for financial support of this research under contract number NSC 102-2221-E-324-006.

#### REFERENCES

- [1] CC2530, A Powerful System-On-Chip for 2.4-GHz IEEE 802.15.4 and ZigBee Applications, Texas Instruments Company, <http://www.ti.com/lit/ds/symlink/cc2530.pdf>
- [2] ESMT F25L016A, 16 Mbit (2Mx8) 3V Only Serial Flash Memory, [http://www.esmt.com.tw/english/main\\_products.asp](http://www.esmt.com.tw/english/main_products.asp)
- [3] IEEE Standards Association, IEEE 802.15.4-2003 – IEEE Standard for Telecommunications and Information Exchange Between Systems – LAN/MAN Specific Requirement – Part 15: Wireless Medium Access Control (MAC) and Physical Layer (PHY) Specifications for Low Rate Wireless Personal Area Networks (WPAN), <http://standards.ieee.org/findstds/standard/802.15.4-2003.html>
- [4] IEEE Standards Association, IEEE 802.15.4-2011 – IEEE Standard for Local and metropolitan area networks – Part 15.4: Low-Rate Wireless Personal Area Networks (LR-WPANs), <http://standards.ieee.org/findstds/standard/802.15.4-2011.html>
- [5] J. Zheng and B. Yang, “Design of Power Supply System for Field Wireless Sensor Network Nodes,” in *Proceedings of 2<sup>nd</sup> International Conference on Instrumentation, Measurement, Computer, Communication and Control (IMCCC)*, pp. 39-43, Harbin, Dec. 2012.
- [6] N. Zhu and I. O’Connor, “Energy Measurements and Evaluations on High Data Rate and Ultra Low Power WSN Node,” in *Proceedings of 10<sup>th</sup> IEEE International Conference on Sensing and Control (ICNSC)*, pp. 232-236, Evry, April 2013.
- [7] R.-S. Semente, A. Silva, A.-O. Salazar, F.D.M. Oliveira, A.-S. Lock, “A energy efficient WSN system for limited power source environments,” in *Proceedings of 7<sup>th</sup> International Conference on Sensing Technology (ICST)*, pp. 193-197, Wellington, Dec. 2013.
- [8] SHT1x/SHT7x Humidity & Temperature Sensor, SENSIRION Company, <http://www.sensirion.com/en/products/humidity-temperature/humidity-sensor-sht11/>
- [9] S. Mini, S.-K. Udgata, S.-L. Sabat, “Sensor Deployment and Scheduling for Target Coverage Problem in Wireless Sensor Networks,” *IEEE Sensor Journal*, Vol. 14, No. 3, pp. 636-644, Oct. 2013.
- [10] TP4057, Standalone Linear Li-ion Battery Charger, Nanjing Top Power Corporation, <http://www.ecranic.com/files/TP4057.pdf>
- [11] W.-C. Lee, J. Ng, and L.-F. Yeung, “Sensitivity improved ZigBee RF receiver for medical sensor,” in *Proceedings of 39<sup>th</sup> Annual Conference on Industrial Electronics Society (IECON2013)*, pp.8447-8453, Vienna, Nov. 2013.