

Analysis of the Theoretical Values of Several Characteristic Parameters of Surface Topography in Rotational Turning

J. Kunderák, I. Sztankovics, K. Gyáni

Abstract—In addition to the increase of the material removal rate or surface rate, or the improvement of the surface quality, which are the main aims of the development of manufacturing technology, a growing number of other manufacturing requirements have appeared in the machining of workpiece surfaces. Among these it is becoming increasingly dominant to generate a surface topography in finishing operations which meets more closely the needs of operational requirements.

These include the examination of the surface periodicity and/or ensuring that the twist-structure values are within the limits (or even preventing its occurrence) in specified cases such as on the sealing surfaces of rotating shafts or on the inside working surfaces of needle roller bearings. In the view of the measurement the twist has different parameters from surface roughness, which must be determined for the machining procedures. Therefore in this paper the alteration of the theoretical values of the parameters determining twist structure are studied as a function of the kinematic properties.

Keywords—Kinematic parameters, rotational turning, surface topography, twist structure.

I. INTRODUCTION

In the development of cutting the appearance of hard turning in finishing operations was a remarkable step [1]. It became possible to produce the same surface roughness and accuracy with defined cutting edged tools as with grinding, though the material removal rate is multiplied compared to abrasive machining [2]. However, some finishing operations put forward requirements which have not been raised in the field of machining with defined cutting edges [3]. One of these demands is to meet the proper operational requirements specified for the machined surface [4].

Therefore, for example, the finishing of sealing surfaces is done by grinding procedures. In these the degree of the twist structure can be lowered or even prevented by the correct selection of process and dressing parameters. By the in feed variant of grinding and with the choice of sufficient spark-out time the generated surface topography can be influenced in a positive direction. Any disfunctionality due to the twist on the surface, oil-leakage or the rapid bursting of sealings can be avoided by the application of this grinding procedure in industrial practice.

However, hard turning was become an alternative procedure

J. Kunderák, I. Sztankovics, and K. Gyáni are with the Institute of Manufacturing Science, University of Miskolc, Miskolc-Egyetemváros, H-3515, Hungary (phone: +36(46) 565160; e-mail: janos.kunderak@uni-miskolc.hu, sztankovics@uni-miskolc.hu, karoly.gyani@uni-miskolc.hu).

to grinding in the view of accuracy and surface roughness [5]. It has spread very swiftly: it has been widely applied in the very competitive automotive industry due to its productivity and environmental friendly features. However the replacement of grinding must be carried out with caution. If the operation requirements demand the limitation or the elimination of twist structure, then methods for this must be examined in hard turning as well.

There are cases when the generated periodical (or twisted) topography can act as a limit on application, because for example shaft surfaces machined in this way are unsuitable for dynamic seals [6]. When the prevention of the twist-structure generation is the goal, grinding cannot be replaced, so in other words hard turning is not an alternative to grinding in these cases.

To maintain the advantages and avoid the disadvantages of hard turning, novel variants of the procedure are developed. One of these solutions is the application of a combined procedure, where the workpiece must not be moved to the grinding machine, because a machine tool suitable for combined machining is able to perform both operations. Hence the turning and grinding are done in one clamping of the workpiece, so there is no clamping error in the grinding operation. Therefore a smaller material layer must be removed in grinding.

Another solution for the decrease in twist structure can be rotational turning [7] carried out by a helical geometric cutting edge, and this is the target of our studies. In this paper we determine the calculation method for the theoretical values of the twist parameters in machined surfaces of rotational turning and furthermore we investigate the alteration effect of the kinematic parameters on these attributes.

II. STATE OF THE ART OF ROTATIONAL TURNING RESEARCH

There are few publications so far, which contains theoretical and experimental examinations on rotational turning. The work of Klocke et al. [8] presents rotational turning as a novel cutting procedure by the combination of longitudinal turning and peripheral turn-milling.

The aim of their study is to determine the achievable surface roughness. They calculate the theoretical value of total height of profile (R_t) by the well-known equation with axial feed (f) and the nose radius (r_ϵ):

$$R_t \approx f^2 / 8r_\epsilon \quad (1)$$

They state that neither the feed nor the nose radius can be defined in the classical way for the helical geometric tool of rotational turning. The axial feed comes from the rotational movement of the tool, so several attributes must be taken into consideration in its determination. For the calculations in (1) they defined a virtual feed, which is calculated on a geometric and kinematic basis, and this is substituted into the equation. For the definition of the nose radius the same method was applied: they calculated a virtual value which comes from the cutting edge geometry. Then the calculated theoretical values of the total height of profile were compared to measured values on machined surfaces with given technological parameters. Based on the 2D profiles they stated that rotational turning generates a periodical topography. However, at 0.3mm feed and below, this profile cannot be observed, as the peak-valley height and the virtual radius are not measurable. Furthermore they determined that the calculated and measured values of the total height of profile (R_t) are in good correlation, so they stated that the described method has been verified in practice. However, actually the measured R_z values are significantly different from the calculated R_t values. The authors state that this is not surprising in hard turning but a natural consequence of the plastic deformations in cutting with small chip cross-sectional areas.

In another work of Klocke and his colleagues [9] comparative experimental examinations can be seen between rotational turning and traditional hard turning on some parameters of surface quality. They compare the roughness and the waviness of these procedures at different feeds. They calculated that in case of rotational turning the virtual nose radius is 61.16mm while the nose radius is 1.2mm in traditional hard turning. Then they state that to achieve the same R_z , a six-fold higher feed can be adjusted in rotational turning than in traditional hard turning. However, at the same feed the peak-to-valley height is almost ten-fold higher in traditional hard turning than in rotational turning. They investigated the alteration of the depth of grooves as well. They also extended the study to the influence of the workpiece diameter. They found that at higher diameters the depth of the grooves is smaller than at lower diameters.

Schubert et al. [10] propose a new hard turning procedure which can generate a twist-free structure on the surface. In the frame of their experimental work they did experiments with normal and wiper CBN inserts. They observed that with the same feed the theoretical supply cross section (DF) of the surface is lowered from $546\mu\text{m}^2$ to $17.2\mu\text{m}^2$ with wiper inserts. On the basis of this they manipulated the feed motion so that the tool stops for one rotation of the workpiece, then moves linearly with the value of one feed between the two standing position. They give the procedure the name "Start-Stop-Turning" (SST), and say that it is guaranteed to make twist-free surfaces [10]. This procedure looks simpler in geometry than the other procedures for machining of twist-free surfaces: vibration processing method (1993) [11], tangential turning (2001) [12], rotation turning (2005) [13], and twist-free turning with suitable feed motion (2007) [14]. The authors demonstrate the twist-free characteristics of the shafts

machined by SST with microscopic images.

From this short review it can be seen that scientists are still searching for methods to fulfill more operational requirements in surfaces machined with high-productivity. The target of our research is to investigate by accurate mathematical calculations the opportunities to lower the characteristics of the twist structure with the alteration of the kinematic parameters in rotational turning.

III. THE MICRO-GEOMETRY OF THE TWIST STRUCTURE AND ITS STANDARD PARAMETERS

Twist structure is the name for a periodic-like mark on the machined surface of the workpiece generated by the cutting tool which establishes a conveying effect on the surface during the rotation of the part. This topography is presented on the whole perimeter without interruption, and it has a pitch angle like threaded surfaces. Based on this attribute of the twist structure, it is clear that the proper characterisation of this topography has a crucial importance on sealing surfaces, and can be carried out by standardised parameters [15]. The parameters (whose interpretations can be seen on the sketch in Fig. 1) are:

1. DP – period length [mm],
2. $D\gamma$ – twist angle[° ' "],
3. Dt – twist depth[μm],
4. DG – number of threads[—],
5. DF – theoretical supply cross section [μm^2].

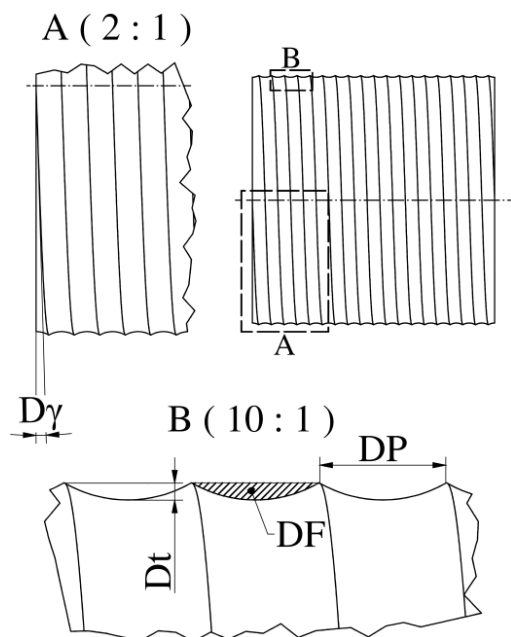

Fig. 1 The parameters of twist measurement

The values of the twist parameters are in the domain of roughness parameters in most cases. Hence the determination of the profiles can be done in a similar manner as for roughness. The connection between the twist and roughness parameters is shown by the fact that in terms of their value the period length of the twist (DP) is equal to the mean spacing of

profile irregularities (R_{sm}), and the twist depth (Di) is equal to the total height of the profile (R_t).

IV. THE APPLIED KINEMATIC-MATHEMATIC MODEL

Hereinafter we examine the machined surfaces in the perspective of twist generation in rotational turning. The method of our study is a mathematical analysis based on a manufacturing geometry model [16], by which we can exactly describe and illustrate the shape and micro-geometry of the surface machined by rotational turning. The essence of the method is mathematic description of the relative movement of the cutting edge and the workpiece by coordinate systems moving along with them. After this the generated profile on the workpiece surface by the cutting edge can be determined with the mathematical equations and proper side-conditions. For the description of the formula of the geometry and the movement of both the workpiece and the tool, two standing coordinate system are also needed. The four coordinate systems and a kinematic sketch of rotational turning can be seen in Fig. 2 [17].

The symbols used in the figure and the mathematical description:

- K_t – standing coordinate system of the tool,
- K_{tm} – moving coordinate system of the tool,
- K_w – standing coordinate system of the workpiece,
- K_{wm} – moving coordinate system of the workpiece,
- l – surface-generating point of the cutting edge,
- ω_w – angular speed of the workpiece,
- ω_t – angular speed of the tool,
- v_a – additional axial feed rate of the tool,
- a_w – axis distance (between the symmetry axes of the tool and the workpiece),
- l_m – initial distance between the standing and moving coordinate systems,
- λ_s – inclination angle of the cutting edge.

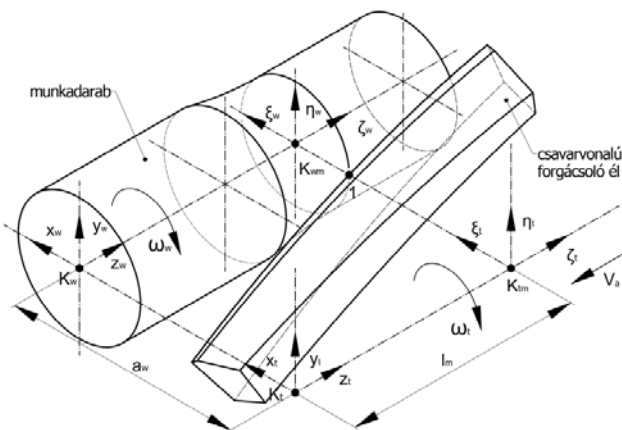

Fig. 2 Kinematical-geometric model of rotational turning, from [17]

The equation of the cutting edge is given in the moving coordinate system of the tool (K_{tm}). However, the movement of the tool can be given in the standing coordinate system of the tool (K_t), with the transformation of the former coordinate

system to the latter by the proper equation. The connection of the two standing coordinate systems (K_t, K_w) is made by the axis distance (a_w). Lastly, the rotary movement of the workpiece is given by the proper transformation between the standing and moving coordinate systems of the workpiece (K_w, K_{wm}). In this way we can get the equation of the machined surface in K_{wm} . The section in the base plane of the cutting edge – defined by the symmetry axes of the workpiece and the tool – of this surface will be the 2D roughness profile of the workpiece. The equation is determined with the method – in the layout presented in Fig. 3 – presented in our previous work [17], [18].

With (2) and (3) the workpiece radius (ζ) of a particular point of the cut surface can be given in function of the axial displacement (ξ).

$$\xi(\zeta) = r_t \cos \left[\frac{\zeta + v_a t}{r_t \cot \alpha_t} + v(\zeta) + (\omega_t t - \omega_w t) \right] - a_w \cos(v(\zeta) + \omega_w t) \quad (2)$$

$$v(\zeta) = \tan^{-1} \left(\frac{r_t \sin \left[\frac{\zeta + v_a t}{r_t \cot \alpha_t} + (\omega_t - \omega_w) t \right] - a_w \sin \omega_w t}{r_t \cos \left[\frac{\zeta + v_a t}{r_t \cot \alpha_t} + (\omega_t - \omega_w) t \right] + a_w \cos \omega_w t} \right) \quad (3)$$

For the upcoming determination of the twist parameters the resultant axial feed in the rotational procedure is also needed. This consists of two parts: axial feed derived from the rotation of the tool and the inclination angle of the edge ($f_{r,a}$) and the possible additional axial feed of the tool (f_{va}). The latter is needed if the length of the workpiece is higher than the axial length of the tool. By the summarisation of these two components the resultant axial feed can be determined [18]:

$$f_a = f_{r,a} + f_{va} = 2\pi \frac{\omega_t}{\omega_w} \left[\frac{r_t}{\tan \alpha_t} + \frac{v_a}{\omega_t} \right] \quad (4)$$

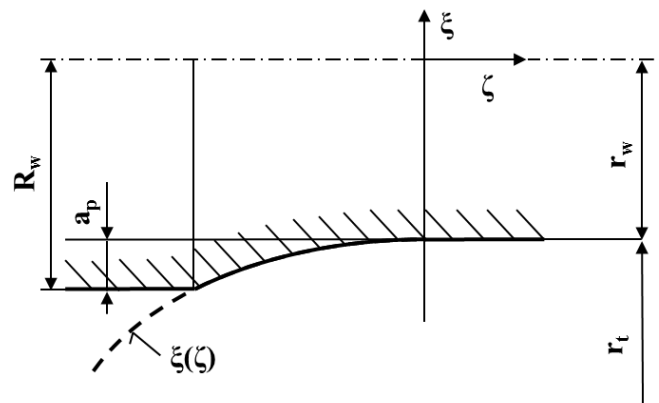

Fig. 3 Illustration of the cut surface equation

V. TWIST PARAMETERS IN ROTATIONAL TURNING

The calculation methods can be given by the previously described method to determine the theoretical values of the different parameters of the twist structure. In this paper we

specify the period length (DP), the twist angle ($D\gamma$) and the twist depth (Dt). After the determination of the theoretical values we examine the alteration effect of the kinematic parameters on these factors.

A. Parameter Determination

We begin the study of the twist structure in surfaces machined by rotational turning with the theoretical determination of each parameter. The period length of the twist is the repetition frequency of the peaks; therefore it is equal to the resultant axial feed. Thus its calculation can be specified on the basis of (4):

$$DP = 2\pi \frac{\omega_t}{\omega_w} \left[\frac{r_t}{\tan \lambda_s} + \frac{v_a}{\omega_t} \right] \quad (5)$$

The pitch angle of the twist can be calculated by the perimeter of the workpiece and the period length of the twist. Therefore it can be described by the following relation:

$$D\gamma = \arctan \frac{DP}{2\pi r_w} = \arctan \frac{\omega_t}{r_w \omega_w} \left[\frac{r_t}{\tan \lambda_s} + \frac{v_a}{\omega_t} \right] \quad (6)$$

The depth of the twist can be determined with the equation of the cut surface and the period length of the twist. The former equation in the cutting edge base plane (the plane defined by the ζ_w and ζ_s axes) is defined in our previous work [17], [18] and is given in (2) and (3). The substitution value of the $\zeta(\zeta)$ function in the proper location (when the ζ value is equal to $f_d/2 = DP/2$) is the exact value of the depth of the twist. With the above taken into consideration, the twist depth can be written as:

$$Dt = -r_t \cos \left[A - \arctan \left(\frac{r_t \sin(A)}{r_t \cos(A) - r_t - r_w} \right) \right] + \frac{r_t + r_w}{\sqrt{1 + \left(\frac{r_t \sin(A)}{r_t \cos(A) - r_t - r_w} \right)^2}} - r_w \quad (7)$$

where:

$$A = \frac{f_a}{2r_t \cot(\lambda_s)} = \frac{\pi}{\omega_w} \frac{(v_a + r_t \omega_t \cot(\lambda_s))}{r_t \cot(\lambda_s)} \quad (8)$$

B. Influence of the Kinematic Parameters

With the determination of the three twist parameters we can examine the alteration effect of the determinant parameters of rotational turning on these characteristic parameters of the machined surface. These factors are the geometrical attributes of the tool and the workpiece and the kinematic properties of the machining procedure.

In this paper we examine the alteration effect of the kinematic parameters (revolution speed of the tool – n_t , revolution speed of the workpiece – n_w , additional axial feed rate – v_a) which influence the values of cutting speed and resultant axial feed, the base parameters of process planning.

For the comparison a mean value for each determinant

process parameter was given (Table I). From these the kinematic parameters were changed in a $\pm 50\%$ range where their effect is examined.

First the pitch angle of the twist ($D\gamma$) is examined. Its alteration can be seen in Fig. 4 as a function of the kinematic parameters.

TABLE I
 MEAN VALUES OF THE CALCULATIONS

parameter name	symbol	unit	value
revolutions of the workpiece	n_w	1/min	1000
revolutions of the tool	n_t	1/min	4
additional axial feed rate	v_a	mm/s	6
diameter of the workpiece	d_w	mm	40
radius of the cutting edge	r_t	mm	60
inclination angle	λ_s	°	40

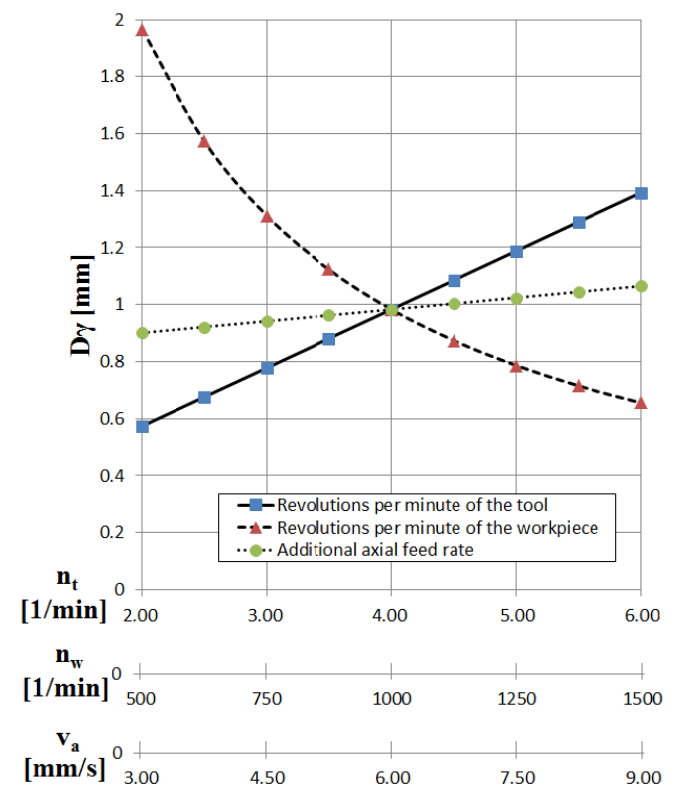

Fig. 4 Effect of the kinematic parameters on the twist angle ($D\gamma$)

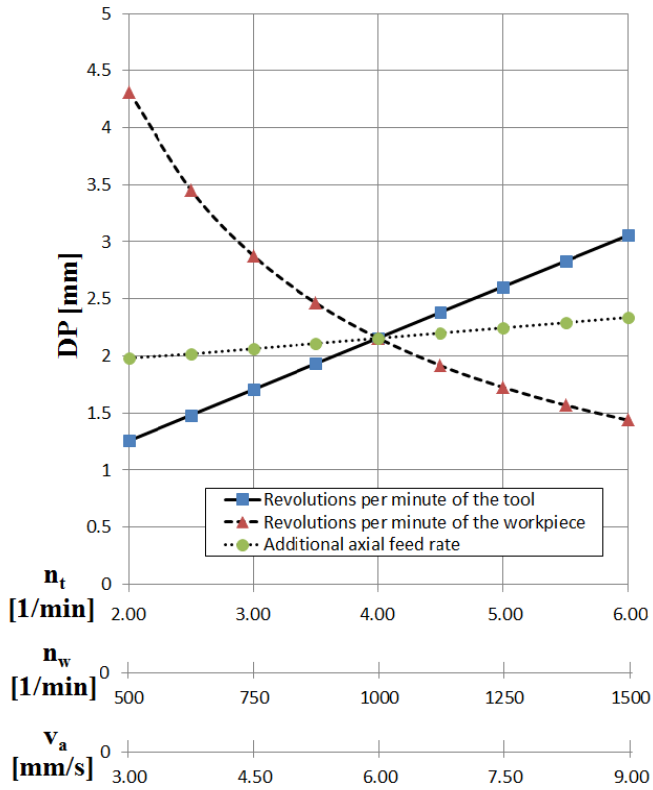

Fig. 5 Effect of the kinematic parameters on the period length of the twist (DP)

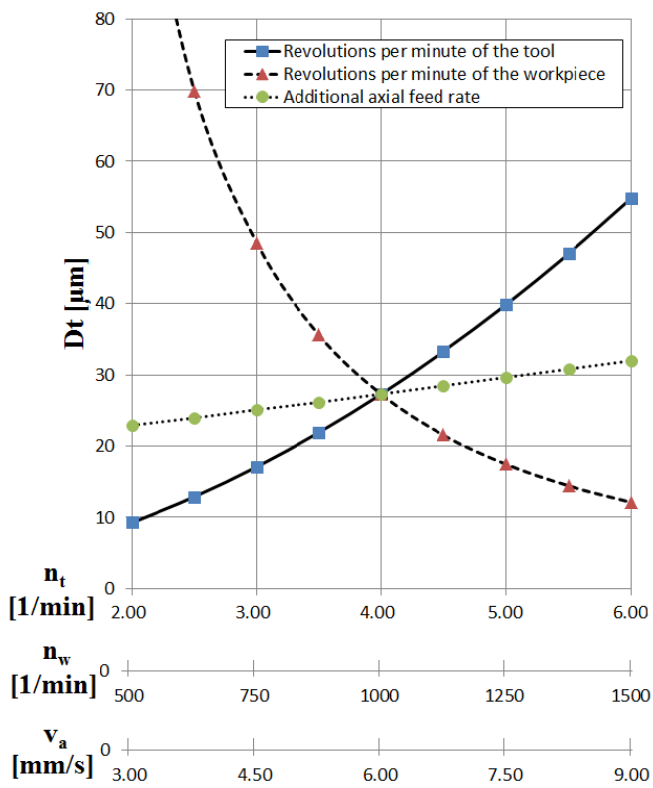

Fig. 6 Effect of the kinematic parameters on the depth of the twist (Dt)

Of the studied parameters, we would like to note that the revolution speed of the workpiece has the highest effect on $D\gamma$. With the increase of this kinematic parameter a significant decrease can be observed in the value of the angle: A three-fold increase decreases the $D\gamma$ value to one-third. The alteration of the other two parameters (revolution speed of the tool, additional axial feed rate) has a linear effect on $D\gamma$. With the increase of these $D\gamma$ will also increase because the resultant axial feed rate will increase as well. The difference between the effects of the two is the intensity of the alteration: a three-fold increase in the rotation speed of the tool means a 2.5-fold increase in the angle, while three-fold increase of the additional axial feed rate means only a 1.15-fold increase in the value of $D\gamma$.

In Fig. 5 the alteration effect of the kinematic parameters on the period length of the twist can be seen. The nature of the alterations is the same as that experienced in the changes of the twist angle. This is caused by the close correlation between the two as presented in (7). Although there are differences in the values, the intensity remains the same.

The influence of the kinematic parameters on the depth of the twist can be observed in Fig. 6. Although the slope direction of each curve is the same, the intensities of the alterations are very different. A three-fold increase in the revolution speed of the workpiece decreases the depth of the twist to one-tenth of its original value. The increase of the revolution speed of the tool will increase the depth: a three-fold increase means a 5.5-fold increase in Dt . Furthermore a three-fold increase of the additional axial feed rate will increase the value of Dt by 1.5-fold.

From the above we can state that the twist depth can be influenced the most intensively in the examined domain by the change of the kinematic parameters. Furthermore, we determine that if the twist angle or depth must be decreased the determinant parameters of the tool's movement must be decreased, and the rotational speed of the workpiece must be increased. However if the target is the increase of the period length then the inverse change of the kinematic parameters is necessary. Therefore in the calculation of the optimal process parameters the production engineer must consider which twist parameter effect must be lowered.

VI. SUMMARY

Hard turning has spread very rapidly in the industrial environment due to its technical, economic and environmental advantages. In many cases it is able to replace the expensive and environmental polluting grinding in finishing operations, because with it the accuracy and quality requirements of the workpieces can be fulfilled. However, the generated surface topography does not always meet the operational requirements, for example these surfaces are not efficient for the operations of dynamic seals. To avoid the periodic topography generated during turning a combined procedure has been developed, where the abrasive (mostly grinding) machining can be done after the turning in one machine, one clamping. Thus the advantageous productivity of turning can be maintained while the topography becomes random.

Another development in the decrease in the periodic character has come to the forefront as an upgraded variant of hard turning. In this, rotational turning is done by a helical geometric cutting edge. Although the patent of rotation was filed in 2005, the first scientifically significant papers were published from 2010. In the papers which are presented and cited here [8], [9] the authors determine the total height of profile on a geometrical basis with mathematical equations. It is stated that the rotational turning generates a periodic topography. During the mathematic analysis some simplifying assumptions and approximation was necessary (and applied). The definition and the examination of the twist structure also appeared in this procedure to characterize the machined surface mostly in rotational turning.

In this study, however, we did not apply approximations, so we describe the machined surface with exact mathematical methods. With the generation of the plane section (which crosses both the workpiece and tool symmetrical axes) of the cut surface, the punctual determination of the twist parameters was given. From our original mathematical analysis we found that the twist parameters in rotational turning were affected by more parameters than in traditional longitudinal hard turning. The specifying factors can be used to adjust the twist parameters: the twist characteristic can be lowered. After this the theoretical values were calculated for different settings of the determinant parameters of the material removal and kinematic relations. We found that of the examined parameters the revolution speed of the workpiece has the most significant effect, while additional axial feed rate has the least effect. The mathematic analysis that has been worked out permits the display of the generated micro-geometrical profile and the fast calculation of the characteristic parameters.

We determined that in the examined range the twist angle changes from 2° to 0.65° , the period length changes from 4.35 mm to 1.5mm and the depth of the twist changes from $109\mu\text{m}$ to $12\mu\text{m}$ with a three-fold increase of the rotational speed of the workpiece. The three-fold increase of the rotational speed of the tool comes with the following effect: the pitch angle changes from 0.6° to 1.4° ; the period length increases from 1.25 to 3mm; the depth of the twist alters from $10\mu\text{m}$ to $55\mu\text{m}$. The additional axial feed rate has only a slight effect on these parameters theoretical values. We found that beside the kinematic parameters, the rotational speed of the workpiece has the most significant effect on the theoretical values of the machined surface twist parameters.

ACKNOWLEDGMENT

This research was (partially) carried out in the framework of the Center of Excellence of Innovative Engineering Design and Technologies at the University of Miskolc.

The work was presented by the support of the Hungarian Scientific Research Fund (Number of Agreement: OTKA K 78482), which the authors greatly appreciate.

REFERENCES

- [1] G.Byrne, D.Dornfeld, B.Denkena, "Advancing Cutting Technology", *CIRP Annals - Manufacturing Technology*, vol. 52, Issue 2, pp483-507, 2003
- [2] F. Klocke, E. Brinksmeier, K. Weinert, "Capability Profile of Hard Cutting and Grinding Processes", *CIRP Annals - Manufacturing technology*, vol. 54, pp. 22-45, 2005
- [3] M. C.Shaw, *Metal Cutting Principles*, Oxford University P, New York, 651 p., 2005
- [4] M. Wizner, W. Jakubiec, M. Starczak, "Description of surface topography of sealing rings", *Wear* vol. 271, pp. 571-575, 2011
- [5] J. Kundrák, B. Karpuschewski, K. Gyáni, V. Bana, "Accuracy of hard turning", *Journal of Material Processing Technology*, vol. 202, pp. 328-338, 2008
- [6] T.Kunsfeld, *Einfluss der Wellenoberfläche auf das Dichtverhalten von Radial-Wellendichtungen*, (PhD. Dissertation), Uni Stuttgart, 2005.
- [7] J.G. WeisserSöhne GmbH & Co: Patent Anmeldung, St.Georgen, Germany, 2004
- [8] F.Klocke, T.Bergs, F.Degen, P.Ganser, "Presentation of a novel cutting technology for precision machining of hardened rotationally symmetric parts", *Production Engineering: Research and Development*, vol. 7, pp.177-184, 2013
- [9] F.Degen, F.Klocke, T. Bergs, P.Ganser, "Comparison of rotational turning and hard turning regarding surface generation", *Production Engineering: Research and Development*, (to be published) 2014
- [10] A.Schubert, R.Zhang, P.Steinert, "Manufacturing of Twist-Free Surfaces by Hard Turning" *Productia CIRP*, vol. 7, pp.294-298, 2013
- [11] Patent DE4119162C1 (1991) Gebr. HellerMaschinenfabrik
- [12] Patent DE19963897A1 (1999) Schreiber, L.;Trott, K.
- [13] Patent DE102004026674B3 (2004) Kummer, N.
- [14] Patent DE102006009276B3 DE (2006) KG,Felsomat GmbH & Co.
- [15] MBN 31007-7 (2002) Daimler Chrysler AG, Stuttgart
- [16] B. A.Perepelica, *Otobrazenijaaffinnogoprosztransztva v teoriiformobrazovanijapoverhnosztejrezanijem*, Harkov, p. 152, 1981
- [17] I. Sztankovics, J. Kundrák, "Mathematical Description of Machining External Cylindrical Surface in Case of Rotational Turning", *Cutting & Tooling in Technological System*, vol. 82, pp. 264-269, 2012
- [18] I. Sztankovics, J. Kundrák, "Theoretical Value of Total Height of Profile in Rotational Turning", *Applied Mechanics and Materials*, vol. 309, pp. 154-161, 2013