

# Adjustment and Compensation Techniques for the Rotary Axes of Five-axis CNC Machine Tools

Tung-Hui Hsu, Wen-Yuh Jywe

**Abstract**—Five-axis computer numerical control (CNC) machine tools (three linear and two rotary axes) are ideally suited to the fabrication of complex work pieces, such as dies, turbo blades, and cams. The locations of the axis average line and centerline of the rotary axes strongly influence the performance of these machines; however, techniques to compensate for eccentric error in the rotary axes remain weak. This paper proposes optical (Non-Bar) techniques capable of calibrating five-axis CNC machine tools and compensating for eccentric error in the rotary axes. This approach employs the measurement path in ISO/CD 10791-6 to determine the eccentric error in two rotary axes, for which compensatory measures can be implemented. Experimental results demonstrate that the proposed techniques can improve the performance of various five-axis CNC machine tools by more than 90%. Finally, a result of the cutting test using a B-type five-axis CNC machine tool confirmed to the usefulness of this proposed compensation technique.

**Keywords**—Calibration, compensation, rotary axis, five-axis computer numerical control (CNC) machine tools, eccentric error, optical calibration system, ISO/CD 10791-6

## I. INTRODUCTION

FIVE-axis computer numerical control (CNC) machine tools (three linear and two rotary axes) are ideally suited to the fabrication of complex work pieces, such as dies, turbo blades, and cams. A number of measurement systems for five-axis CNC machine tools have been developed, such as the probe ball, which comprises a 3-dimensional probe and a double ball bar DBB, the R-test system from IBS Precision Engineering, the LaserTRACER system from Etalon AG, the touching probe from HEIDENHAIN GmbH and Renishaw plc, and the Non-bar system [1]-[7].

Precision in assembly has a major influence on the performance of machine tools. Calibration techniques used for three-axis CNC machine tools have matured considerably in the twenty years since their initial development; however, compensatory methods for eccentric error in the rotary axes of five-axis CNC machine tools remain weak. Details of a measurement method using a master ball and linear displacement sensor(s), and a double ball bar (DBB) from ISO/CD 10791-6 [8] are shown in Fig. 1.

Srivastava et al. [9] presented an analytical method using Denavit-Hartenberg (D-H) transformations to obtain the total

volumetric error throughout the workspace resulting from the geometric and thermal error associated with individual components in a five-axis CNC machine tool.

Jha et al. [10] used a one-dimensional ball array to increase the performance of a five-axis machining centre in improving the quality of cam profiles.

Tsutsumi et al. presented an algorithm to identify specific deviations using three types of simultaneous three-axis control motion [11], four-axis control motion [12] and spherical motion [13] for each rotary axis. In this approach, two translational axes and one rotary axis are simultaneously controlled to maintain a constant distance between the tool and worktable. The measurement path resembles the tool center point function (TCP) in the general controller and a single telescoping ball bar is used to identify deviations.

Bringmann et al. [14] presented an instrument for calibrating 5-axes machining centers as well as a novel Monte Carlo approach using full machine error modeling to determine the expected overall geometric behavior of the machine tool following calibration. Ibaraki et al. [15] presented a calibration method for five-axis machine tools in a revision of ISO standards using the DBB5. The DBB5 is a standard DBB in which the master ball is supported at a 45 degree angle to the spindle axis. Ibaraki et al. [16] also presented a method of calibrating motion error in the rotary axes of five-axis machine tools using the R-test. However, this compensation technique is not specifically applicable to five-axis machine tools. Erkan et al. [17] presented a method for rapidly assessing volumetric distortion in five-axis machines using a reconfigurable 3-D ball artifact. Unfortunately, this method does not allow the calibration of the artifact, which prevents the evaluation of uncertainty in this method. Ibaraki et al. [18] presented a scheme to calibrate location error in the rotary axes according to on-the-machine measurement of a test piece using a square gauge and a contact-type touch-trigger probe installed on the spindle. When the touch-trigger probe touches the square gauge, a sampling signal triggers a device to record the location of the machine tool in the x, y, and z directions. The use of an indicator and square gauge resembles conventional calibration schemes in the manufacturing industry.

Unfortunately, none of these methods addresses the specific needs of the machine tool industry. This paper proposes optical (Non-Bar) techniques applicable to the calibration of five-axis CNC machine tools including compensation for eccentric error in the rotary axes. This approach employs the measurement path in ISO/CD 10791-6 to determine eccentric error, which can then be used for the accurate application of compensatory measures.

Tung-Hui Hsu is with the Department of Automation Engineering, National Formosa University, No.64, Wen-Hua Rd., Huwei Township, Yunlin County 632, Taiwan, ROC (corresponding author to provide phone: 886-5-631-5400; fax: 886-5-631-5401; e-mail: tunghui.hsu@gmail.com).

Wen-Yuh Jywe is with the Department of Automation Engineering, National Formosa University, No.64, Wen-Hua Rd., Huwei Township, Yunlin County 632, Taiwan, ROC (e-mail: jywe@nfu.edu.tw)

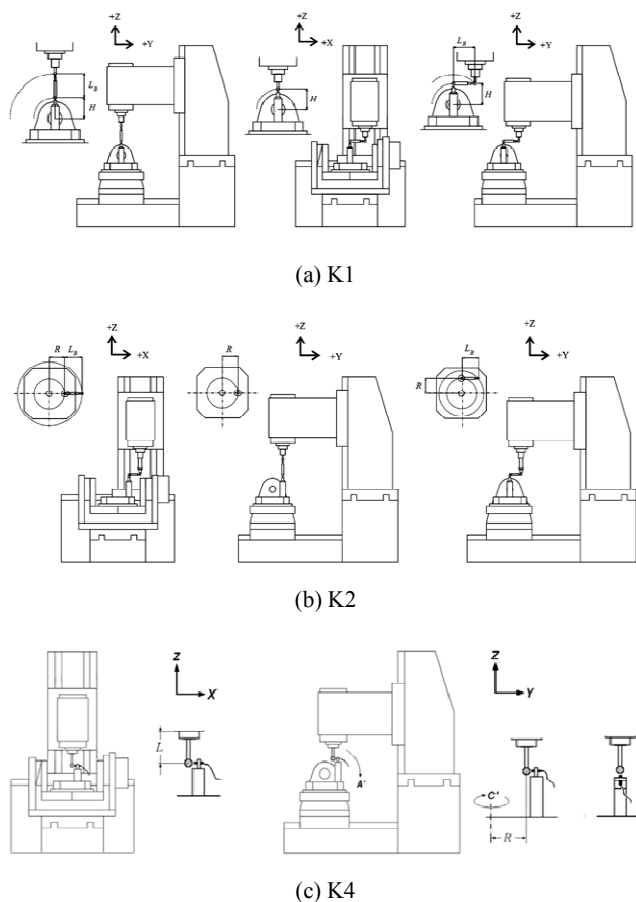

Fig. 1 Measurement method using a DBB [8]

## II. PRINCIPLE

A five-axis CNC machine tool with three linear axes and two rotary axes is susceptible to 43 types of geometric error, including 21 along the linear axes and 22 along the rotary axes [19]. Rotary-axis geometric error includes component and positional (location) errors [19]. Component error can be attributed to the quality of components; positional error is the result of imprecision in assembly.

Positional error (IOJ), in the center of the rotary axes (A, B and C) is defined in ISO 230-2 and referred to as eccentric error. IOJ reflects the positional error of the motion-axis (J) in the direction of the error-axis (I). Eccentric error can be traced back to imprecision in assembly; therefore, it is considered a form of positional error.

General controllers in five-axis CNC machine tools have a tool center point (TCP) / triory function to maintain the tool in a constant position by providing instantaneous responses to variations in position along the rotary axes. When the TCP is enabled, the NC code is produced by the CNC controller, whereupon the trajectories of the multi-axis motion (one rotary axis with two linear axes, one rotary axis with three linear axes or two rotary axes with three linear axes), can be simultaneously performed at a constant speed. Fig. 2 presents a process diagram of the TCP function. To produce the NC cord of the linear axes, the CNC controller calculates the location of

the center of the rotary axes, the length of the tool, and the starting point. Thus, listing the correct location of the center of two rotary axes among the parameters of the CNC controller is crucial. Eccentric error is a form of positional error; therefore, static measurement is an effective approach for its characterization. Finally, we employed the least squares method [20], [21] to fit a circle and thereby obtain the eccentric error.

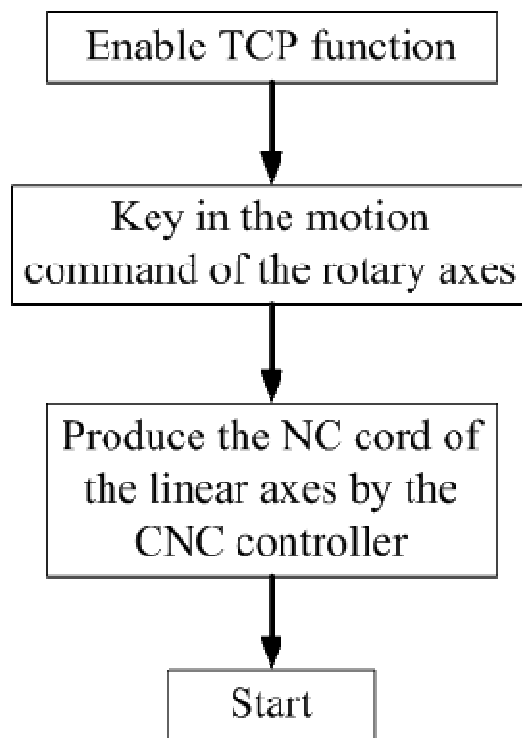
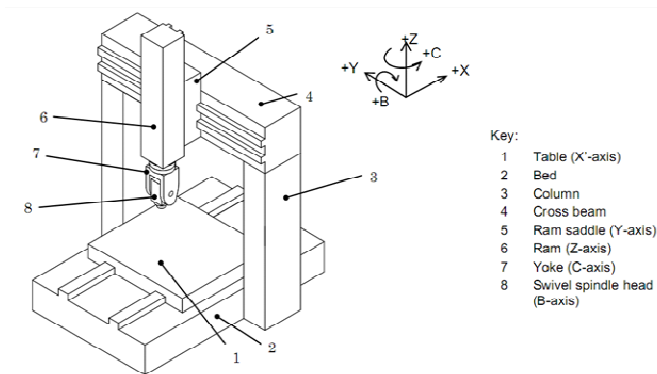

Fig. 2 Process diagram of the TCP function

## III. MEASUREMENT PATH

Five-axis CNC machine tools are comprised of three linear axes and two rotary axes. The measuring and compensation sequences must accord to the type of the five-axis CNC machine tool. Classified the positions of the two rotary axes during assembly, the machine tool can be divided into three types: A-type, B-type and C-type, as shown in Fig. 3. A-type refers to the assembly of both rotary axes on the spindle head. B-type refers to the assembly of the two rotary axes on the spindle head and table, respectively. C-type refers to the assembly of both rotary axes on the table. The details can be found in ISO/CD 10791-6. The measurement path of CNC five-axis machine tools can be found in Annex A, Annex B, and Annex C of ISO/CD 10791-6.



(a) Typical example of a vertical five-axis machining center with double pivot spindle head (A-type)

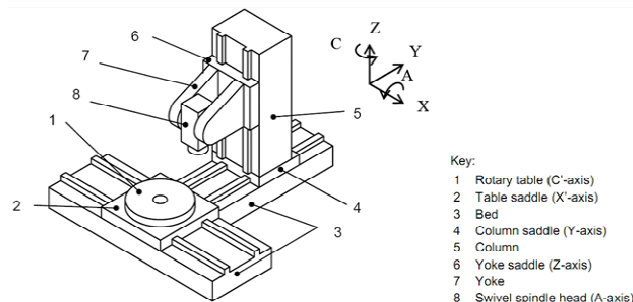

(c) Typical example of a vertical five-axis machining center with a swivel head and rotary table (C-type)

Fig. 3 Three classes of five-axis CNC machine tools [8]

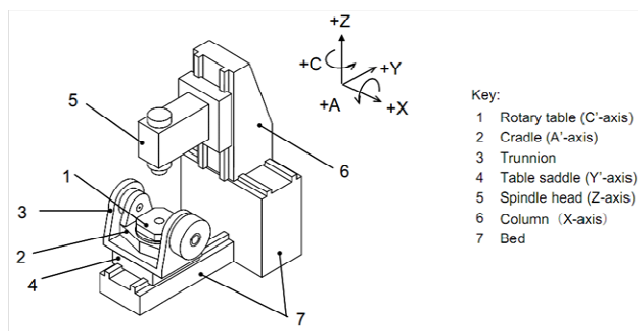

(b) Typical example of a vertical five-axis machining center with tilting rotary table (B-type)

Accurately locating the centers of the two rotary axes is crucial to the performance of five-axis CNC machine tools. Specifically, five-axis CNC machine tools employ simultaneous multi-axis motion. To obtain accurate results for the measurement of eccentric error in the rotary axes, this study employed the K1 and K2 measurement paths in ISO/CD 10791-6 for the calibration of the rotary axes.

#### IV. CALIBRATION AND COMPENSATION

In this section, we outline the calibration of B-type five-axis machine tools with a Heidenhain controller (i530), including compensation for error. Measurements details are presented in Table I.

TABLE I  
MEASUREMENT PARAMETERS OF B-TYPE FIVE-AXIS MACHINE TOOLS

Typical of the machine tool	Measurement path	Rotary axes	Interpolation axes	Start angle (degrees)	Interval (degrees)	End angle (degrees)
B-type	K1	A	Y and Z	-25	5	30
	K2	C	X and Y	0	30	360

TABLE II  
COMPARING THE RESULTS OF THE UNCOMPENSATED AND THE COMPENSATED

Measurement path	Rotary axes	Interpolation axes	Error ( $\mu\text{m}$ )		Improving rate
			Uncompensated	Compensated	
K1	A	Y	between -140 and 140	between -5 and 9	95%
		Z	between 0 and 280	between 0 and 10	96%
K2	C	X	between -7 and 31	between -2.5 and 2.5	87%
		Y	between -24 and 18	between -2.5 and 2.5	88%

The three linear axes (X, Y, and Z) and two rotary axes (A and C) were built using traditional power train components, including ball-screws, linear guild ways, and worm wheel mechanisms. The maximum ranges of travel in the A and C axes are from  $-30^\circ$  to  $90^\circ$  and  $360^\circ$ , respectively. During measurement, the detector module was fixed to the spindle head and the ball lens module was fixed to the table. The measurements details are presented in Table I. According to the mechanism chain, the eccentric errors in the B axis (the first rotary axis) and C axis (the second rotary axis) were calibrated in sequence while compensating for error. The results of calibration and compensation in which eccentric errors in the A and C axes reduced to within 14 and  $5\mu\text{m}$ , respectively, as

shown in Table II.

#### V. CONCLUSION

Eccentric error is a major source of geometric error in five-axis CNC machine tools. This study employed the least squares method in a non-bar system to calibrate CNC machine tools and compensate for eccentric error. We employed the measurement path in ISO/CD 10791-6 to determine the eccentric error in the two rotary axes of five-axis CNC machine tools and determined the compensation sequence according to the mechanism chain associated with the specifics of the CNC machine tools. The proposed methods reduced eccentric error

by approximately 70% in the three types of five-axis CNC machine tools (A-type, B-type and C-type) commonly used in industry. The proposed method is characterized by easy setup,

#### ACKNOWLEDGMENT

This research was supported by the Ministry of Economic Affairs, Taiwan, Republic of China, (102-EC-17-A-05-S1-188).

#### REFERENCES

- [1] Lei, W. T. and Hsu, Y. Y., "Accuracy test of five-axis CNC machine tool with 3D probe-ball. Part II: errors estimation," *International Journal of Machine Tools and Manufacture*, Vol. 42, Issue 10, pp. 1163-1170(2002)
- [2] Weikert, S., "R-Test, a New Device for Accuracy Measurements on Five Axis Machine Tools," *CIRP Annals - Manufacturing Technology*, Vol. 53, Issue 1, pp. 429-432(2004)
- [3] Bringmann, B. and Knapp, W., "Model-based 'Chase-the-Ball' Calibration of a 5-Axes Machining Center," *CIRP Annals - Manufacturing Technology*, Vol. 55, Issue 1, pp. 531-534(2006)
- [4] Schwenke, H., Schmitt, R., Jatzkowski, P. and Warmann, C., "On-the-fly calibration of linear and rotary axes of machine tools and CMMs using a tracking interferometer," *CIRP Annals - Manufacturing Technology*, Vol. 58, Issue 1, pp. 477-480(2009)
- [5] Erkan, T. and Mayer, J. R. R., "A cluster analysis applied to volumetric errors of five-axis machine tools obtained by probing an uncalibrated artifact," *CIRP Annals-Manufacturing Technology*, Vol. 59, 539-542(2010)
- [6] United States Patent, "Detecting assembly for a multi-axis machine tool", Wen-Yuh Jywe, Chien-Hung Liu, Tung-Hui Hsu and Chia-Ming Hsu, Patent no. 7,852,478, 2010/12/14
- [7] Wenyuh Jywe, Tung-HuiHsu and C.-H.Liu, "Non-bar, an optical calibration system for five-axis CNC machine tools", *International Journal of Machine Tools & Manufacture*, Vol. 59, pp. 16-23(2012)
- [8] "Test conditions for machining centres – Part 6: Accuracy of speeds and interpolations", COMMITTEE DRAFT ISO/CD 10791-6, ISO/TC 39 / SC 2 N 1769, 2009-06-17
- [9] Srivastava, A. K., Veldhuis, S. C. and Elbestawit, M. A., "Modelling geometric and thermal errors in a five-axis CNC machine tool", *International Journal of Machine Tools & Manufacture*, Vol. 35, No. 9, pp. 1321-1337(1995)
- [10] Jha, B. K. and Kumar, A., "Analysis of geometric errors associated with five-axis machining centre in improving the quality of cam profile," *International Journal of Machine Tools & Manufacture*, Vol. 43, pp. 629-636(2003)
- [11] M. Tsutsumi and A. Saito, "Identification and compensation of systematic deviations particular to 5-axis machining centers Identification", *International Journal of Machine Tools & Manufacture*, Vol. 43, pp. 771-780(2003)
- [12] Masaomi Tsutsumi and Akinori Saito, "Identification of angular and positional deviations inherent to 5-axis machining centers with a tilting-rotary table by simultaneous four-axis control movements", *International Journal of Machine Tools & Manufacture*, Vol. 44, pp. 1333-1342(2004)
- [13] K.M. Muditha Dassanayake, Masaomi Tsutsumi and Akinori Saito, "A strategy for identifying static deviations in universal spindle head type multi-axis machining centers", *International Journal of Machine Tools & Manufacture*, Vol. 46, pp. 1097-1106(2006)
- [14] B. Bringmann and W. Knapp, "Model-based 'Chase-the-Ball' Calibration of a 5-Axes Machining Center", *Annals of the CIRP* Vol. 55, pp. 531-534 (2006)
- [15] Soichi Ibaraki, Yoshiaki Kakino, Takayuki Akai, Naoshi Takayama, Iwao Yamaji, Keiji Ogawa, "Identification of Motion Error Sources on Five-axis Machine Tools by Ball-bar Measurements (1st Report) – Classification of Motion Error Components and Development of the Modified Ball Bar Device (DBB5) –", *Journal of the Japan Society for Precision Engineering*, Vol. 76, No. 3, pp. 333-337(2010)
- [16] Bohez, E. L. J., Ariyajunya, B., Sinlapeecheewa, C., Shein, T. M. M., Lap, D. T. and Belforte, G., "Systematic geometric rigid body error identification of 5-axis milling machines," *Computer-Aided Design*, Vol. 39, pp. 229-244(2007)
- [17] Tibet Erkan, J.R. Rene Mayer and Yannick Dupont, "Volumetric distortion assessment of a five-axis machine by probing a 3D reconfigurable uncalibrated master ball artifact", *Precision Engineering*, Vol. 35, pp. 116-125(2011)
- [18] Soichi Ibaraki, Takeyuki Iritani and Tetsuya Matsushita, "Calibration of location errors of rotary axes on five-axis machine tools by on-the-machine measurement using a touch-trigger probe", *International Journal of Machine Tools & Manufacture*, Vol. 58, pp. 44-53 (2012)
- [19] "Test code for machine tools - Part 2: Determination of accuracy and repeatability of positioning numerically controlled axes", *International Organization for Standardization*, ISO 230-2(2006)
- [20] Walter Gander, Gene H. Golub and Rolf Strebler, "Least-Squares Fitting of Circles and Ellipses", *BIT Numerical Mathematics*, Vol. 34, No. 4, 558-578(1994), DOI: 10.1007/BF01934268
- [21] N. Chernov and C. Lesort, "Least squares fitting of circles", *Department of Mathematics University of Alabama at Birmingham*, pp. 1-23(2008), <http://www.math.uab.edu/~chernov/cl/cl1.pdf>