

Maximum Power Point Tracking by ANN Controller for a Standalone Photovoltaic System

K. Ranjani, M. Raja, B. Anitha

Abstract—In this paper, ANN controller for maximum power point tracking of photovoltaic (PV) systems is proposed and PV modeling is discussed. Maximum power point tracking (MPPT) methods are used to maximize the PV array output power by tracking continuously the maximum power point. ANN controller with hill-climbing algorithm offers fast and accurate converging to the maximum operating point during steady-state and varying weather conditions compared to conventional hill-climbing. The proposed algorithm gives a good maximum power operation of the PV system. Simulation results obtained are presented and compared with the conventional hill-climbing algorithm. Simulation results show the effectiveness of the proposed technique.

Keywords—Artificial neural network (ANN), hill-climbing, maximum power-point tracking (MPPT), photovoltaic.

I. INTRODUCTION

RENEWABLE energy sources development has attracted research attention, especially after the energy crisis and environmental issues such as global warming and pollution. There has been significant progress in the development of renewable energy sources such as combined heat and power (CHP) applications, solar photovoltaic (PV) modules, small wind turbines, heat and electricity storage, where controllable loads are expected to play a significant role in future electricity supply.

The photovoltaic (PV) system technologies have increasing roles in electric power technologies, providing more secure power sources and pollution-free electric supplies. Solar photovoltaic is a phenomenon where the solar irradiation is converted directly into electricity through solar cell. The PV array can supply the maximum power to the load at a particular operating point which is generally called as maximum power point, at which the entire PV system operates with maximum efficiency and produces its maximum power. The output voltage and current of a PV panel vary with irradiation, panel temperature and power loading nonlinearly [1]. Under certain atmospheric condition, there exists a maximum power point. To draw maximum power from PV panel, a large number of researchers have proposed maximum power point tracking algorithms [2]. PV systems are considered to be one of the most important renewable energy sources, because they are considered to be an effective and efficient solution to environmental problems [3]. The PV energy source system can operate in grid-connected or standalone mode under different loads and system conditions.

K.Ranjani is with the Department of Power Electronics and Drives, in Paavai Engineering College Namakkal, Tamil Nadu, India (e-mail: ranjani.keee@gmail.com).

Microgrid technology offers improved service reliability, better economics, and a reduced dependency on the local utility [4]. Advanced power electronic technology that includes power converters, pulse width-modulation (PWM) techniques, control algorithms, and electronic control units are required for the microgrids technology [5], [6].

A standalone PV-based system is economically superior where other sources of energy are impossible or difficult to use, such as in mobile applications, transportation, and satellite systems. Unfortunately, PV systems suffer from three main problems: high fabrication cost, low conversion efficiency especially under variable weather conditions, and the nonlinearity between the PV array output power and current [7].

Maximum power-point tracker (MPPT) is required to handle such problems and ensure that the PV system is operating at the maximum power point (MPP). Many different MPPT techniques have been proposed. The existing techniques vary in simplicity, accuracy, time response, popularity, cost, and other technical aspects. The voltage base MPP tracking method uses the fact that the ratio between the maximum power voltage and the open circuit voltage under different weather conditions, are linearly proportional [8]-[10]. Since this method is based on an approximation of a constant ratio, the extracted power is most likely to be below the actual MPP, which results in significant loss of the available power. A similar MPPT method, called current-based MPPT, has been proposed. This method approximates the ratio between the maximum power current and the short circuit current under different weather conditions. The same limitations and disadvantages as the voltage base MPPT exist with this method [11] [12].

Fuzzy Logic based MPPT method but it is very difficult to formulate the fuzzy rules, which are usually obtained from the trial-and-error procedure [13] [14]. Hill-climbing method in this system the power oscillates about the MPP. The oscillation can be minimized by reducing the perturbation step size. However, a smaller perturbation size slows down the MPPT. Hill-climbing can fail under rapidly changing atmospheric conditions [15]. The incremental conductive method is widely used because of implementation simplicity and high tracking efficiency. The method is based on the derivative of power over voltage being zero at the MPP, positive on the left of the MPP, and negative on the right. Complex computation is required to give good performance under rapidly varying weather conditions [16].

In this paper hill-climbing algorithm with ANN controller is proposed for MPPT in a standalone PV system. The

drawbacks of conventional hill-climbing are investigated. This proposed MPPT can track the maximum power point faster and also it can minimize the voltage fluctuation after MPP has been recognized. This MPPT eliminates the drawbacks of the hill-climbing method.

II. PV MODEL

PV array consists of solar cells, where each cell is basically a p-n junction. The equivalent circuit of a solar cell is shown in Fig. 1.

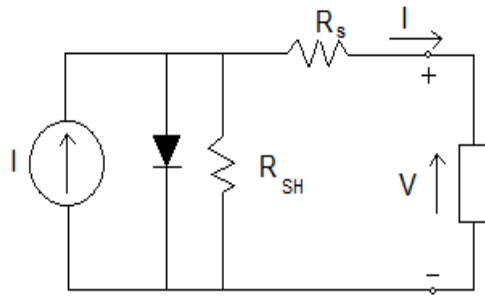

Fig. 1 Equivalent circuit of a PV cell

PV array modeling can be implemented from the mathematical model in (1), which is derived from a cell's equivalent circuit where all cells are identical.

$$I_{pv} = n_p \cdot I_{ph} - n_p \cdot I_o \left[e \left(\frac{q(V_{pv} + R_s I_{pv})}{AKTn_s} \right) - 1 \right] - n_p \left(\frac{V_{pv} + R_s I_{pv}}{n_s R_{sh}} \right) \quad (1)$$

where V_{pv} and I_{pv} represent the PV array output voltage and current, respectively. R_s and R_{sh} are the solar cell series and shunt resistances. q is the electron charge (1.6×10^{-19} C); I_{ph} is the light generated current, I_o is the reverse saturation current, A is dimensionless junction material factor, k is Boltzmann constant 1.38×10^{-23} JK $^{-1}$, T is the temperature (in Kelvin), and n_p and n_s are the number of cells connected in parallel and series, respectively. For a given PV array system, the power-duty cycle (P - D) characteristics under varying weather conditions are shown in Fig. 2.

G is the solar radiation and T is the absolute temperature. As shown in Fig. 2, the optimum power points are located at a specific duty cycle that varies according to weather conditions.

Therefore, either direct or indirect coupling can be used to operate the PV array at its optimum power point. In direct coupling, the PV array is directly connected to the load and periodic fine tuning is required. In the other method, indirect coupling, automatically tracking of the optimum operating point is facilitated by connecting a power converter between the PV array generator and the load. The power converter switch is controlled by MPPT algorithm to draw array maximum output power.

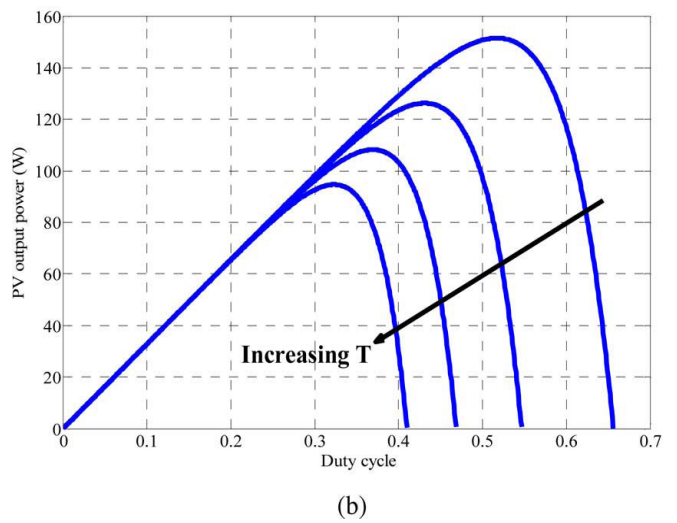
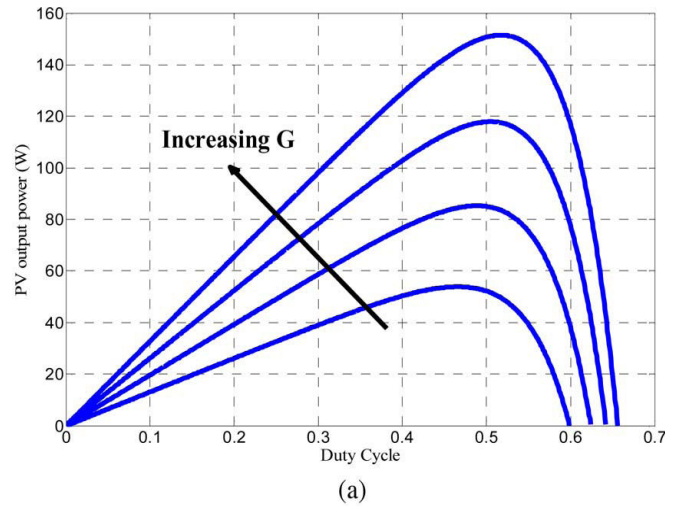

Fig. 2 Influences on P - D characteristics by (a) solar radiation (G) and (b) temperature (T) influence

III. CONVENTIONAL HILL-CLIMBING TECHNIQUE

Hill-climbing operates by perturbing the system by changing the power converter duty cycle and observing its impact on the array output power. The hill-climbing MPPT method is the most commonly used algorithm in practice because of simplicity, easy implementation, and low cost. However, it has three major drawbacks.

- 1) Slow converging to the optimum operating point.
- 2) At steady-state condition, the amplitude of the PV power is oscillates around the maximum point that causes system power losses.
- 3) During cloudy days when the irradiance varies quickly the operating point moves away from the maximum optimum point.

Fig. 3 shows the behavior of the PV system controlled by the conventional hill-climbing MPPT. The PV output power is forced to move toward the optimum point by a hill-climbing algorithm. After reaching the optimum point, the PV output power oscillates around the MPP.

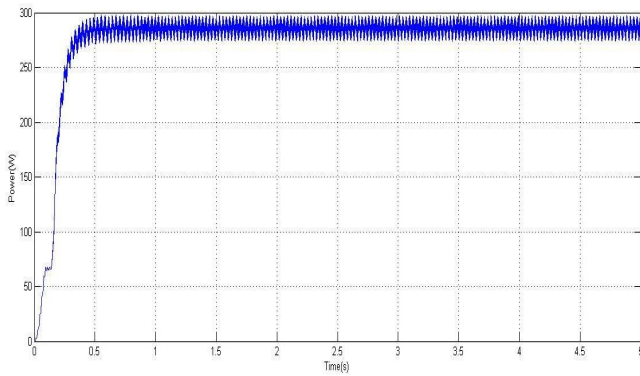

Fig. 3 PV output power of the hill-climbing method

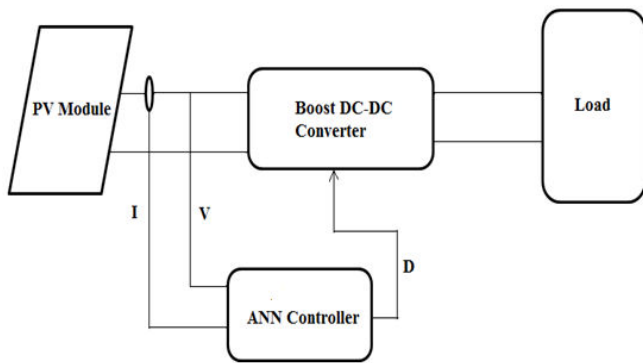

Fig. 4 Block diagram of the PV system with the proposed MPPT controller.

IV. ARTIFICIAL NEURAL NETWORK

Artificial neural network has the potential to provide an improved method of deriving non-linear models which is complementary to conventional techniques. Neural networks have a self adapting capability which makes them well suited to handle the parameter variations.

The artificial neuron consists of input, activation function and output with respected weight. The higher a weight of an artificial neuron is the stronger the input which is multiplied by its weight. Weights can also be negative, so the signal is inhibited by the negative weight. Depending on the weights, the computation of the neuron will be different. The weights of the artificial neuron are adjusted to obtain the outputs for the specific inputs.

A. Feed-forward Neural Network

The feed-forward neural network is the first and simplest type of artificial neural network devised. The feed-forward neural network consists of several types. In this network, the information moves in only one direction, forward, from the input nodes, through the hidden nodes (if any) and to the output nodes. There are no cycles or loops in the network. A single-layer perceptron network, which consists of a single layer of output nodes; the inputs are fed directly to the outputs via a series of weights. In this way it can be considered the simplest kind of feed-forward network. The sum of the products of the weights and the inputs is calculated in each

node, and if the value is above some threshold (typically 0) the neuron fires and takes the activated value of (typically 1); otherwise it takes the deactivated value (typically -1). Neurons with this kind of activation function are also called artificial neurons or linear threshold units. In the literature the term perceptron often refers to networks consisting of just one of these units

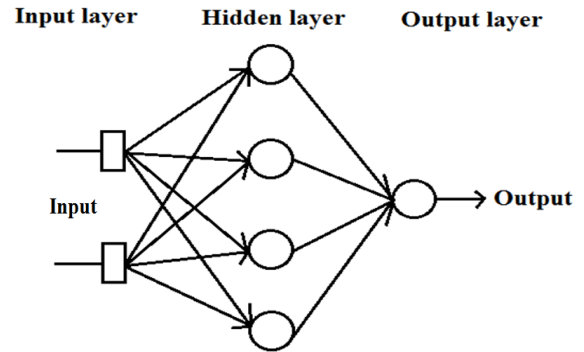

Fig. 5 Architecture of Neural Network

A perceptron can be created using any values for the activated and deactivated states as long as the threshold value lies between the two. Most perceptrons have outputs of 1 or -1 with a threshold of 0 and there is some evidence that such networks can be trained more quickly than networks created from nodes with different activation and deactivation values. Perceptrons can be trained by a simple learning algorithm that is usually called the delta rule. It calculates the errors between calculated output and sample output data, and uses this to create an adjustment to the weights, thus implementing a form of gradient descent. Single-unit perceptrons are only capable of learning linearly separable patterns. Although a single threshold unit is quite limited in its computational power, it has been shown that networks of parallel threshold units can approximate any continuous function from a compact interval of the real numbers into the interval [-1,1]. A learning rule for very simple universal approximators consisting of a single layer of perceptrons.

The algorithm used for training is back-propagation. The back-propagation training algorithm needs only inputs and the desired output to adapt the weight. This method performs a gradient descent on the error surface which is a function of the line current error. A gradient descent minimization can be performed on the error function. Back-propagation training is referred to as supervised training. The neural network was trained using MATLAB software.

V. SIMULATION CIRCUIT AND RESULT ANALYSIS

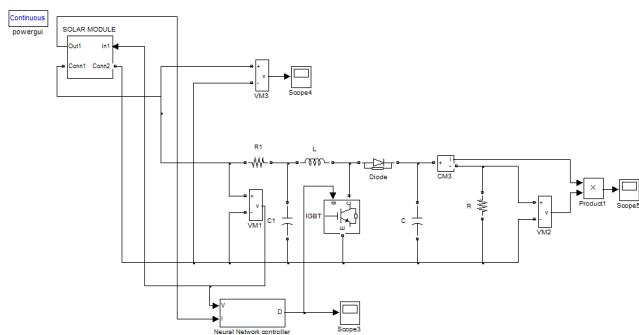

Fig. 6 Simulation Circuit of Proposed System

The circuit diagram of proposed system is shown in Fig. 6. In the proposed system the solar panel is connected with the boost converter. The temperature and radiation is given to the solar panel. Normally the solar panel works on 1000w/m^2 and 25° . The voltage and the current is taken from the solar panel. The hill-climbing algorithm is used with the neural network controller and produced the duty cycle to track the maximum power point. Maximum power point tracking technique is used to improve the efficiency of the solar panel. In this neural network, the information moves in only one direction, forward, from the input nodes, through the hidden nodes and to the output nodes. There are no cycles or loops in this network.

TABLE I
 DESIGN SPECIFICATION AND CIRCUIT PARAMETERS

| Item | Value |
|----------------------------|-------|
| PV array rated power, P(W) | 330 |
| Boost inductor, L(mH) | 1 |
| Smoothing capacitor, C(mF) | 2 |

The maximum power point tracking of photovoltaic system using hill-climbing algorithm with neural network controller were simulated in MATLAB/SIMULINK. The PV panel output voltage is shown in the Fig. 7. The voltage from the PV panel is 45 volt.

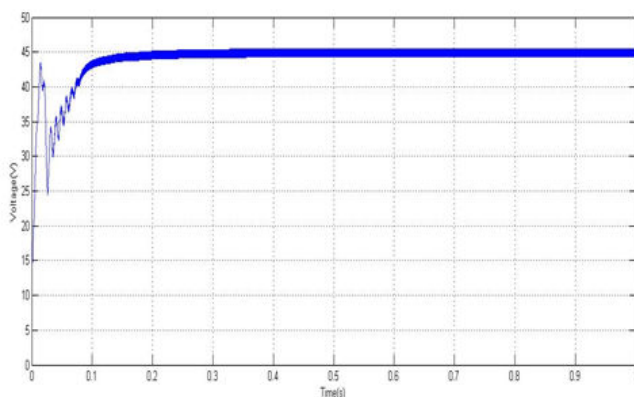

Fig. 7 Voltage from Solar Panel

Fig. 8 shows the output voltage waveform of the boost converter. The input of the boost converter is obtained from the solar panel. Based on the hill-climbing algorithm with the neural network controller produced the duty cycle and it was given to IGBT to produce the Boost output voltage. The output current of the proposed system is shown in Fig. 9.

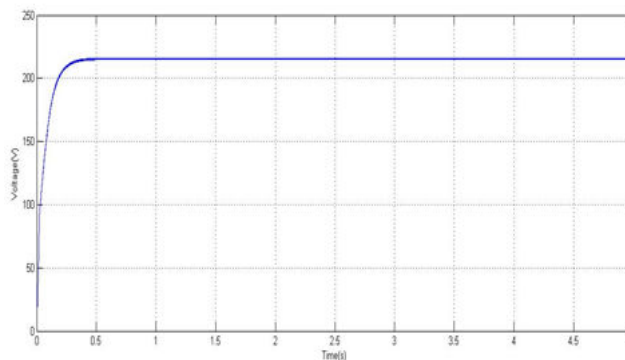

Fig. 8 Output Voltage Waveform

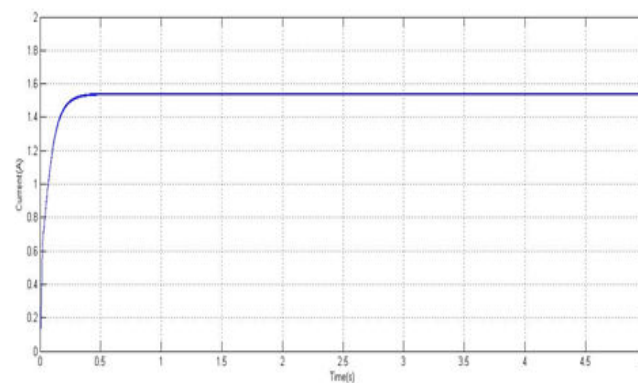

Fig. 9 Output current Waveform

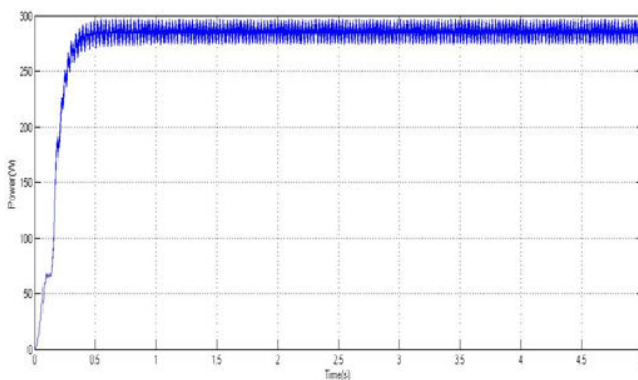

Fig. 10 Output Power Waveform of Hill-Climbing Algorithm

Fig. 10 shows the output power of the boost converter which is obtained by the hill-climbing algorithm. It tracked maximum power with more oscillations. This oscillation is reduced by the proposed system and losses are also reduced is shown in Fig. 11.

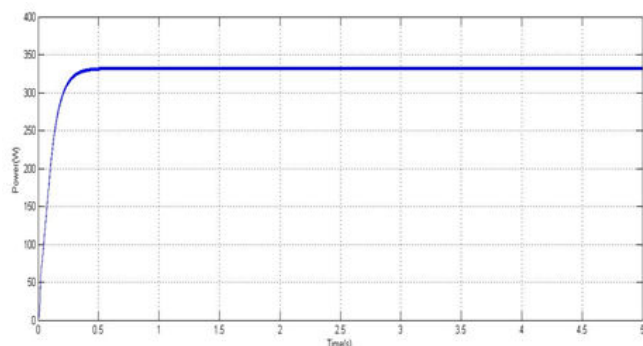

Fig. 11 Output Power Waveform of Proposed Method

VI. CONCLUSION

In this proposed system an intelligent control algorithm of MPPT for the PV system along with the Neural Network is used to track the Maximum Power Point. This proposed method is implemented to reduce the drawbacks of the hill-climbing algorithm. Simulink model was used to verify the outcome of both hill-climbing and the proposed approach. The results of the proposed MPPT exhibit a fast converging speed, less oscillation around the MPP under steady-state conditions and no divergence from the MPP during varying weather conditions. The feasibility and effectiveness of the proposed method were evaluated and compared with the hill-climbing algorithm.

REFERENCES

- [1] Jui-Liang Yang, Ding-Tsair Su and Ying-Shing, "Research on MPPT and Single-Stage Grid-Connected for Photovoltaic System" WSEAS Transactions On Systems, Vol. 7, pp.1117- 1131, October 2008.
- [2] Trishan Eswar and Patrick L. Chapman, "Comparison of Photovoltaic Array Maximum Power Point Tracking Techniques", IEEE Transactions on Energy Conversion, Volume 22, No. 2, pp.3766-3771, June 2007.
- [3] B. Szabados and W. Fangnan, "A maximum power point tracker control of a photovoltaic system," in Proc. IEEE Instrum. Meas. Technol. Conf. 2008, pp. 1074-1079.
- [4] H. Ying-Tung and C. China-Hong, "Maximum power tracking for photovoltaic power system," in Proc. 37th IAS Annu. Meeting. Ind. Appl. Conf. Rec., 2002, vol. 2, pp. 1035-1040.
- [5] Shuai Jiang, Dong Cao and Yuan Li, "Grid-Connected Boost-Half-Bridge Photovoltaic Microinverter System Using Repetitive Current Control and Maximum Power Point Tracking", IEEE Transactions On Power Electronics, Vol. 27, No. 11, pp.4711-4723, December 2012.
- [6] Chih-Lung Shen, Cheng-Tao Tsai, Jye-Chau Su, and Yi Chan, "Grid-Connection Single-Stage Photovoltaic Inverter System with Double-Linear-Approximation MPPT", IEEE Transaction Power Electronics, Vol. 7, No. 3, pp.2324-2330, June 2011.
- [7] Roger Gules, Juliano De Pellegrin Pacheco, Hélio Leães Hey and Johninson Imhoff, "A Maximum Power Point Tracking System with Parallel Connection for PV Stand-Alone Applications", IEEE Transactions on Industrial Electronics, Volume 55, No. 7, pp.1887-1894, July 2008.
- [8] Ait Cheikh.M.S and Abdelkader Mami, "Voltage Oriented Control Applied to a Grid Connected Photovoltaic System with Maximum Power Point Tracking Technique", American Journal of Applied Sciences, Volume 10, 2007.
- [9] Rosa A. Mastromauro, Marco Liserre, Tamas Kerekes and Antonio Dell' Aquila, "A Single-Phase Voltage Controlled Grid Connected Photovoltaic System with Power Quality Conditioner Functionality", IEEE Transaction, Vol.8, pp.2765-2774, December 2008.
- [10] Jung. Y.S, Choi.J.Y and Kim.G.S, "A novel two-mode MPPT control algorithm based on comparative study of existing algorithms", Elsevier Journal, pp.455-463, 2004.

- [11] Samer Alsadi, Basim Alsaid, "Maximum Power Point Tracking Simulation for Photovoltaic Systems Using Perturb and Observe Algorithm", International Journal of Engineering and Innovative Technology (IJET) Volume 2, December 2012.
- [12] J.Youngseok, S. Junghun, Y. Gwonjong, and C. Jaeho, "Improved perturbation and observation method (IP&O) of MPPT control for photovoltaic power systems," in Proc. IEEE 31st Photovoltaic Spec. Conf. Rec., 2005, pp. 1788-1791.
- [13] Rasoul Rahmani, Mohammadmehdi Seyedmahmoudian, Saad Mekhilef and Rubiyah Yusof, "Implementation of Fuzzy Logic Maximum Power Point Tracking Controller for Photovoltaic System", American Journal of Applied Sciences, Page No 209-218, 2013.
- [14] Alireza Rezaei and Asghar Gholamian.S, "Optimization of New Fuzzy Logic Controller by Genetic Algorithm for Maximum Power Point Tracking in Photovoltaic System", ISESCO Journal Of Science And Technology, Vol. 9, No.15, May 2013.
- [15] Bader N. Alajmi, Khaled H. Ahmed, Stephen J. Finney, and Barry W. Williams, "Fuzzy-Logic-Control Approach of a Modified Hill-Climbing Method for Maximum Power Point in Microgrid Standalone Photovoltaic System", IEEE Transaction Power Electronics, Vol. 26, No. 4, pp.2546-2552, April 2011.
- [16] Liu.C, Wu.B and Cheung.R, "Advanced Algorithm For Mppt Control Of Photovoltaic Systems". Canadian Solar Buildings Conference, August 2004.

K.Ranjani received her B.E Degree in Electrical & Electronics Engineering from Mahendra Engineering College, Namakkal, Tamil Nadu, India in 2011. Currently she is pursuing M.E in Power Electronics and Drives in Paavai Engineering College affiliated to Anna University-Chennai, Tamil Nadu, India and likely to complete in June 2014. Her research interests in Renewable Energy and Control Systems.

M.Raja received the Master Degree from Anna University-Coimbatore, Tamil Nadu, India. He is currently working as Assistant Professor in Paavai Engineering College, Tamilnadu, India. He has published Papers in various International Journals and Conferences. His Major Research Area is Renewable Energy.

B.Anitha received her B.E Degree in Electrical & Electronics Engineering from Mahendra Institute of Technology, Namakkal, Tamil Nadu, India in 2011. Currently she is pursuing M.E in Power Electronics and Drives in Paavai Engineering College affiliated to Anna University-Chennai, Tamil Nadu, India and likely to complete in June 2014. Her research interests in Renewable Energy and Power Converters.