

A Simple Electronic Curvy Length Measurement System: Application to Geography

Arijit Roy, Sharmistha Roy, Dibyendu Chatterjee

Abstract—This article describes an interesting and inexpensive laboratory experiment for undergraduate students of electronics, geography and related disciplines. The objective of the proposed experiment is to improve the students' exposure on the basic principles of instrumentation and to demonstrate an electronic measurement system. A simple electronic curvy length measurement system is presented here. Such a system can be used to measure curvy lengths e.g. length of a river, road or railway line etc. from topographical map. The proposed system is composed of simple functional blocks which are usually demonstrated in laboratory or in theory course of electronics at the undergraduate level. The experiment is assigned to a group of students and it is found that the experiment can fulfill its objectives with high degree of satisfaction.

Keywords—Curvy length measurement, Education, Electronics, Laboratory experiment, Topographical map.

I. INTRODUCTION

LABORATORY experiments are the major source of knowledge for educating students in science disciplines. Cost effectiveness of experimental setup and learning deliverables are the key factors in adapting any laboratory experiment into students' curriculum. For students of electronics, geography and related disciplines, an effective laboratory experiment is proposed in this work.

The main objective of this work is to propose an efficient laboratory experiment on electronic measurement system at the undergraduate or postgraduate level. By performing the proposed experiment, students will gain hand-on-experience about the (i) role of various functional blocks or elements and their interfacing in instrumentation, (ii) construction of a simple measurement system, (iii) various features of electronic measurement system etc.

To measure the length of curvy line on a map, mechanical rotameter, curvimeter, map-measurer, opisometer etc. are commonly used. Today, electronic map measurers (with high level of precision) are also available commercially. However, the objective of the present work is to demonstrate a cost effective simple curvy length measurement system as a laboratory experiment for undergraduate students. Further, it is to be noted that, simple experiment which provides direct application, delivers better learning impacts. All the functional blocks of the proposed system are commonly taught in theory (or laboratory) at the undergraduate level. Hence, simple

Arijit Roy and Dibyendu Chatterjee both are with the Department of Electronics, West Bengal State University, Barasat, Kolkata, India 700126 (Phone: +91-9051503636; e-mail: arijitroy@live.com).

Sharmistha Roy is with Asutosh College, Kolkata, India 700026 (Phone: +91-9874758375; e-mail: sharmistharoy29@gamil.com).

components which are easy to assemble in laboratory are proposed to construct the measurement system.

An electro-mechanical rotary encoder is used as a primary sensor for the proposed system. This type of rotary encoder is often found in computer mouse as a scroll wheel. A shaft-wheel system provides switching which in turn constitutes the encoder. The wheel is moved along the target curvy line. The rotation of the encoder wheel produces electronic pulses. These pulses are filtered, shaped and then counted. In order to count the number of pulses generated by the encoder, a mod-100 counter is constructed. For data presentation, two-digit seven segment display is used.

The above mentioned concept of measuring curvy length is implemented using simple laboratory components. The functional blocks of the system is described in detail. The entire system is tested, verified and presented.

II. ELECTRONICS CURVY LENGTH MEASUREMENT SYSTEM

The proposed electronic measurement system consists of very simple functional blocks which are commonly used in instrumentation. Similar to many other electronic measurement systems, this electronic system consists of (i) Primary sensing element, (ii) Signal conditioning element, (iii) Data collection element, (iv) Data presentation element. In terms of functional blocks, the entire system is shown in Fig. 1. The description on each of these blocks of the system is presented in subsequent sections.

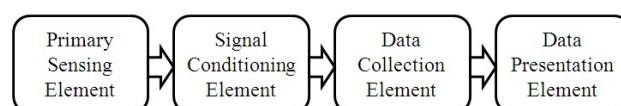

Fig. 1 Block diagram of the proposed system

A. Primary Sensing Element

An electro-mechanical rotary encoder is used for primary sensing element. The electro-mechanical rotary encoder basically acts a rotary switch [1]. The scroll wheel of computer mouse is one of the simplest electro-mechanical rotary encoders. Such an encoder is schematically shown in Fig. 2.

The encoder consists of three terminals for electrical connection. These terminals are labeled as A, C and B as shown in Fig. 2. At stationary condition, there are no contacts made by the encoder between the terminals A, B, C (see Fig. 2). During the rotation of the shaft, the terminal C first makes contact to the terminal A and then to the terminal B. Next, the contact between the terminals C and A breaks and then the

contact between the terminals C and B breaks. Upon reversal of the rotational direction, the sequence of these contacts reverses. The durations of contacts between the terminals C, A and C, B and disconnection are dependent on the speed of rotation of the encoder wheel.

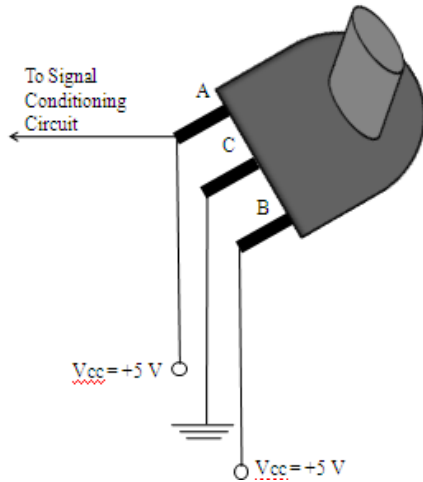

Fig. 2 Schematic of electro-mechanical rotary encoder along with biasing. This circuit acts as primary sensing element of the curvy length measurement system

Suppose, the encoder is biased as shown in Fig. 2 (for practical consideration, the actual biasing differs from what is shown in Fig. 2 and will be discussed later). While in rotation, when the encoder terminal C switches (connects) to the terminal A, the voltage of the terminal A becomes 0 V (from 5 V) for a while. Next, the voltage of the terminal B becomes 0 V (from 5 V) and then the disconnection between the terminals C and A, raises the voltage of the terminal A to 5 V. In a similar way, next the voltage of the terminal B rises to 5 V. The waveform generation due to the rotation is schematically shown in Fig. 3. In this way, the terminals A, B produce pulses as a result of the rotation of the encoder wheel. Any one of the two terminals A or B can be used for the proposed electronic system and the terminal A of the encoder is chosen arbitrarily.

B. Signal Conditioning Element

The pulses obtained from the terminal A (or B) consist of noise and are not as perfect as shown in Fig. 3. The switching behaviour of the encoder is de-bouncing/bouncing in nature and thus produces noise [2]. The nature of the noise and the pulse depends on the speed of rotation. To overcome this type of problem, use of Schmitt Trigger inverter as a debouncer is very common in digital electronics. Here also, in order to obtain well shaped pulses (similar to what is shown in Fig. 3), HEX Schmitt Trigger Inverter (IC 7414) as a switch debouncer is used for conditioning the signal from the encoder [3], [4]. The circuit configuration of the signal conditioning element is shown in Fig. 4. Hence, for practical consideration, instead of directly biasing the terminal A of the encoder to +Vcc, it is connected to the +Vcc through a pull-up resistor (47 kΩ) and also to the ground through a capacitor.

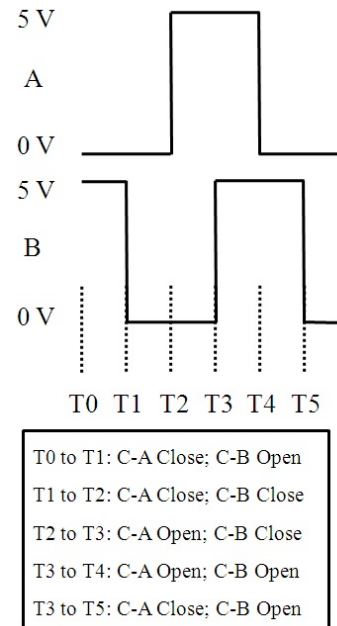

Fig. 3 Rotational events of the encoder. The upper and lower pulse trains representing the pulse train of the terminal A and B respectively. T0, T1 etc. are representing various discrete rotational time intervals

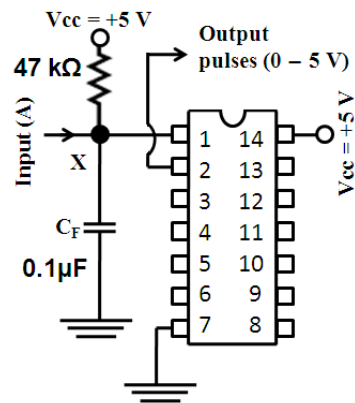

Fig. 4 Signal conditioning element using IC 7414

The functionality of the signal conditioning element can be explained with the aid of the circuit shown in Fig. 4. In this circuit the capacitor C_F ($0.1\mu\text{F}$) is charged through the pull-up resistor ($47\text{ k}\Omega$) towards V_{cc} when the switch is open (i.e. when there is no contact between C and A terminals of the encoder).

The time constant of charging is $\tau_c = RC = 47\text{ k}\Omega \times 0.1\mu\text{F} = 4.7\text{ ms}$. When the charging voltage of the capacitor at the point X (in Fig. 4) exceeds the upper threshold of the Schmitt Trigger, then the output voltage is switched to 0 V. If the switch is now closed (i.e. when the contact is made between C and A terminals of the encoder), the capacitor discharges rapidly through the low resistance path of the closed switch towards the ground. Assuming the wire resistance to be 10Ω , the time constant of discharge is $\tau_d = 10\Omega \times 0.1\mu\text{F} = 1\mu\text{s}$. So at the first closure of the switch the output jumps to 5 V and at this

moment, the voltage at X, V_X goes below the lower threshold voltage of the Schmitt Trigger.

When the switch is closed it may bounce rapidly at the contact point for a short time. During bouncing the switch opens and the capacitor tries to charge towards V_{cc} but before it charges to upper threshold voltage of the Schmitt Trigger, the switch is closed again because the time constant of charging is large compared to the time for which the switch remains open during bouncing for a good quality switch. Moreover, whatever charge the capacitor collects during charging for short duration of bouncing will discharge when the next contact is made during bouncing. Hence, the voltage at X will always remain below the upper threshold voltage and output voltage will remain stable at 5 V during the bouncing. In this way, we can have well shaped pulse train for the terminal A.

The switching speed is also needed to be considered while specifying the RC combination of the signal conditioning circuit. When the encoder is operated manually (by human), a total of 24 contacts per revolution are generated. Since, in the present circuit, the terminals A (out of A and B) is used, 12 pulses per revolution are captured. The fastest rate at which a user could reasonably be expected to turn the encoder wheel is two revolutions per second. This would result a 25 Hz signal, which is equivalent to a 40 ms switch, comfortably longer than the charging time $\tau_c = 4.7$ ms and practically removes the restriction on the rotational speed during the measurement.

C. Data Collection Element

A mod-100 counter is used to collect data for the system. A synchronous BCD counter that counts from 0 to 99 is designed and implemented using two IC 7416. The implementation of synchronous BCD counter is very simple (it is usually taught at the undergraduate level) [5]. Two decade counters (i.e. two mod-10 counters) are cascaded to construct a mod-100 counter. The output from the Schmitt Trigger is connected to the clock input of the counter circuit. The counter advances its counts for every positive edge of the pulse appears at its clock. Thus the number of pulses is counted by the system while measuring a curvy length.

For IC 74162, the clear input (\overline{CLR}) is active low and synchronous in nature [5]. As a result, a low level at the clear input resets the counter at the next rising edge of the clock regardless of the levels of load enabled inputs. Thus to initialize the counter, the \overline{CLR} input is made low (i.e. connected to ground) and then a pulse is generated by rotating the encoder manually. The rising edge of this pulse will reset the counter to 00. After that, the \overline{CLR} input is made high (i.e. connected to $+V_{cc}$) again to turn the counter ready to count the incoming pulses. A push bottom switch is used for these connections. The circuit configuration of the data collection element is shown in Fig. 5.

The output states for the bits $Q_3Q_2Q_1Q_0$ are from 0000 to 1001 (= 9_{10}) for first nine pulses (a decade counter has ten states). The chip has a ripple carry output (RCO at the pin 15) and becomes high when $Q_3Q_2Q_1Q_0 = 1001$, since $RCO = EN2 * Q_0 * Q_3$ (where, $EN2 = \text{pin } 10$ is high and connected to

$+V_{cc}$). The RCO of the first counter is connected to the EN1 of the second counter. A high RCO (at pin 15) enables the next counter to start counting. As a result, the tenth pulse causes to $Q_3Q_2Q_1Q_0 = 0000$ and $Q_7Q_6Q_5Q_4 = 0001$ and so on. In this way, a counter is used to collect data from its signal conditioning element of the system.

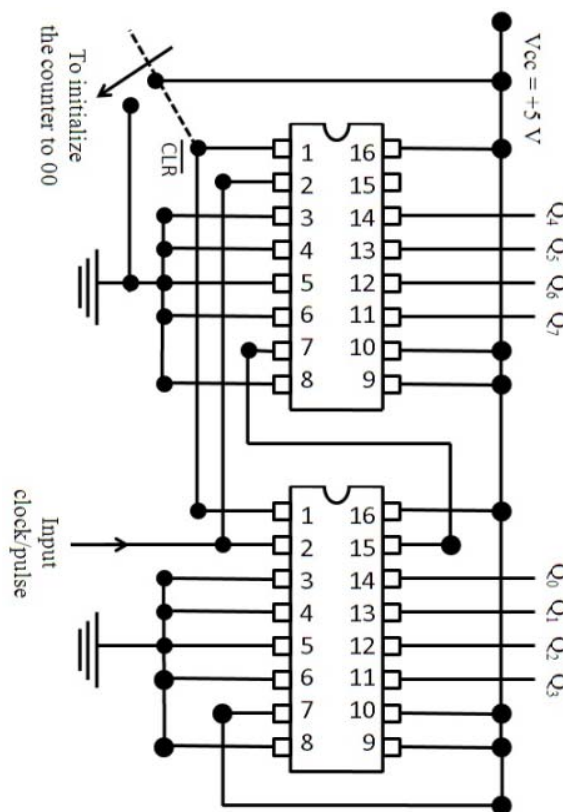

Fig. 5 Data collection element. It is a simple mod-100 synchronous BCD counter using IC 7416

D. Data Presentation Element

A two-digit seven segment display is configured for data presentation. Two IC 7447 are used for decoder as well as for driving the seven segment display. The IC 7447 belongs to TTL family having active low open collector type outputs 'a' to 'g' to drive the LEDs of a common anode type seven-segment-LED display module [6]. A BCD to seven-segment display driver takes a four-bit binary code and displays the corresponding decimal digit. The character of the '4 input bits' is parallel in nature. For example, if the input code is '0100', then it displays the decimal digit '5'. Two such display modules are configured to display decimal numbers of two digits. The circuit configuration is shown in Fig. 6.

The BCD output from the data collection element is fed to the data presentation unit. The display unit displays the number of pulses generated by the encoder in decimal systems. The range of display is 00 to 99 and then again shows 00 to 99 for further appearance of pulses and so on. The display is 00, when it is initialized.

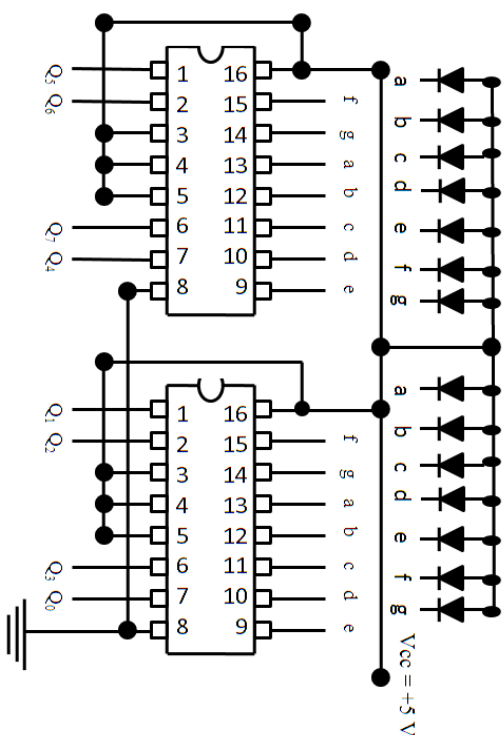

Fig. 6 Data presentation element using IC 7447. It can display decimal numbers from 00 to 99

III. RESULTS AND DISCUSSION

The circuit of the entire system is shown in Fig. 7. In order to calibrate the system, straight lines of known lengths on a paper are considered. Then the encoder wheel is moved along the lines on the paper and the corresponding counts are noted for individual line. After taking several such readings, it is found that one count is equivalent to 0.5cm.

After calibration, a few arbitrary curvy lengths are drawn on another paper and their lengths are measured by this electronic curvy length measurement system. When these measured lengths are compared to those measured by mechanical rotameter, it is found that the maximum deviation of the result measured by the electronic system is 0.5cm. which is equivalent to one count of the system.

Since, the maximum count in one shot is 99 (starting from 00), the maximum length can be measured in a shot is $99 \times 0.5\text{cm}$ i.e. 49.5cm. Longer lengths more than 49.5cm is possible to measure by the system. But in such a case, the user need to manually count the number of appearance of 00 in the display during measurement. Anyway, achieving better (i) range of measurement, (ii) dynamic response, (iii) measuring accuracy etc. are not the objectives of this work.

If the rotational direction of the wheel changes during the measurement, the count still increases. This property of the system is useful when there is a sharp direction change along the target curvy length. Thus the system is immune to the direction of motion.

In order to obtain the usefulness and applications of the system, a few groups of students is considered and they are being asked to construct and study the circuit. By conducting

this laboratory experiment; students are found to gain hands-on knowledge in: (i) splitting an electronic measurement system into simple functional locks, (ii) construction of a simple electronic measurement system, (iii) practical use of counter, seven-segment display module along with their associated circuits, (iv) planning for circuit of a system and common error handling in constructing and testing a circuit of system. Apart from these, the students' also enhances their understanding on the associated theory.

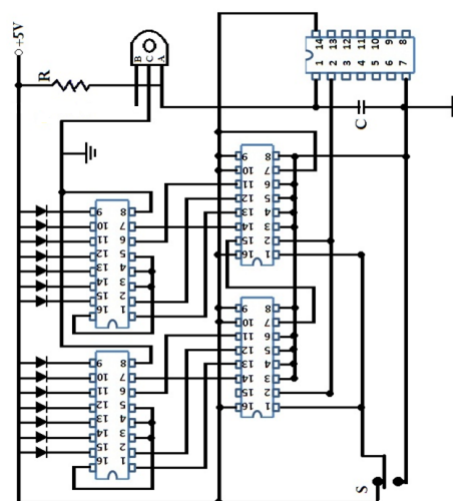

Fig. 7 The complete circuit of the proposed system

Also, the system is directly used to measure the length of a river, road and railway line etc. from topographical maps. Such a map with the target river for which the length is measured is shown in Fig. 8. The same is measured by a commercial mechanical opisometer and it is observed that, the developed system provides result within the desired accuracy. It is also noticed that the developed system gives good repeatability in comparison to the mechanical opisometer.

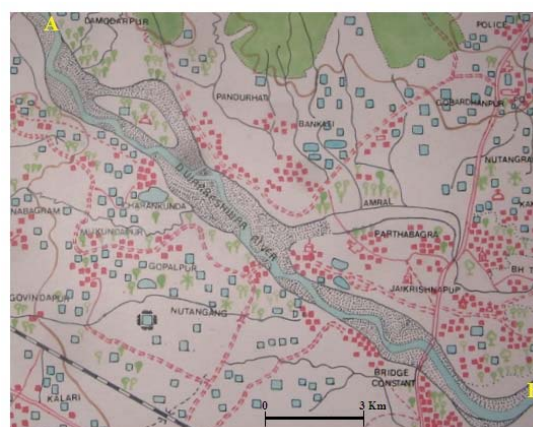

Fig. 8 A part of topographical map of district Bankura, West Bengal (toposheet no. 73 M/8). The length of the river 'Dwarkeshwar' between the points AB is measured to be 11Km using a commercial mechanical opisometer. The same has been measured by the our digital system and the curvy length between the points AB is found to be $11 \pm 0.5\text{Km}$

IV. CONCLUSION

In this work, a laboratory experiment is proposed for electronics related disciplines at the undergraduate level. The proposed experiment is cost effective and provides high deliverables. A simple electronic curvy length measurement system is constructed, tested and presented. The system is constructed using simple functional blocks, those are commonly taught at the undergraduate level. The enhancement of students' learning through this experiment is encouraging and inclusion of this experiment into the undergraduate curriculum of relevant disciplines may be useful. With little modification, the system can have other applications such as measuring rotational speed of a wheel.

The system is applied to measure the length of a river from a geographical map and desired results are obtained.

ACKNOWLEDGMENT

The authors would like to thank to Mr. Sanjib Saha (Lab. Assistant, Electronics Lab., West Bengal State University) and to Mrs. Aparna Adhikari (M.Sc. student of the Electronics Department, West Bengal State University) for their valuable contribution in this project.

REFERENCES

- [1] Web page: <http://circuitelc.blogspot.com/2009/03/rotary-encoder-circuit.html>.
- [2] Web page: <http://electronicdesign.com/article/analog-and-mixed-signal/simple-quadrature-decoder-suits-rotary-encoders214>.
- [3] Texas Instrument, "Data Sheet: SN7414, HEX Schmitt-Trigger Inverters", December 1983.
- [4] Diptiman Ray Chaudhuri, *Digital Circuits*. Volume – II. Kolkata: Platinum Publishers, 2009, ch. 15.
- [5] Diptiman Ray Chaudhuri, *Digital Circuits*. Volume – II. Kolkata: Platinum Publishers, 2009, ch. 13.
- [6] Diptiman Ray Chaudhuri, *Digital Circuits*. Volume – I. Kolkata: Platinum Publishers, 2009, ch. 8.11.

Dr. Arijit Roy has attended many prestigious institutes like IITs, NTU, Infineon Technologies in his career. He earned Ph.D. from School of Electrical and Electronic Engineering, Nanyang Technological University, Singapore. Before pursuing full-time research career, he obtained M.Tech. (Instru. Tech.) and M.Sc. (Physics) from Indian Institute of Technology-Delhi and Indian Institute of Technology-Kharagpur in 2001 and 1999 respectively. He has published many research papers in peer-reviewed international journals of high impact factor (total impact factor of these journals is about 34), four peer-reviewed research papers in international conference of repute (like IRPS, IPFA etc). Apart from these, Dr. Roy has delivered few invited talk in recognized conferences. His research articles are being cited more than 140 times as of now. Among his various publications, a 75-journal-page-size review article (the longest documented work in the history of the topic) on Electromigration published in *Materials Science and Engineering Reports: R* is well received by the community. His another novel work is published in *Microelectronic Engineering* 113 (2014) 152-156. His research interest include: micro/nano-electronics, quantum computation, circuits and systems and science teaching.

He was awarded "International Research Scholarship" from NTU for pursuing Ph.D. He obtained additional research grant from IME, Singapore during his PhD career. He won the prize for second-best-paper in "Symposium On Microelectronics-2004". Also, he ranked 31 (all India) in GATE'99 examination.

Presently Dr. Roy is Assistant Professor in Electronics at West Bengal State University. Before joining to this position, he was employed at Infineon Technologies and NTU in the position of Engineer and Research Associate

respectively. He is the first Head of the Department of Electronics at WBSU, and is involved in shaping the department for academic excellence.

Sharmistha Roy obtained B.Sc. (Hons.) and M.Sc. in Geography with specialization in Cartography from the University of Calcutta. Apart from these, she completed certificate course in GIS from Centre for Energy and Development Studies, Kolkata. Her research interests include: Remote Sensing and GIS, Cartography, Population Geography. She has also published regular research paper in the journal "Geographical Review of India".

After completion of her M.Sc, she got experienced as Lecturer in Budge Budge College, 24-Pgs (South) and Rammohan College, Kolkata. Her knowledge and skills are further enriched while she was working as a Research Assistant at National Institute of Education (NIE), Singapore. After coming back to Kolkata, she joined as a guest teacher in Geography at Asutosh College for teaching UG and PG students. During her tenure as a guest teacher, she got research fund from UGC, Govt. of India under UGC-Minor-Research-Scheme (Memo No. F.PSW-029/11-12 (ERO), S.No. 205867, Dated: 03-Aug-11). Presently, she is working as Research Assistant in a project funded by ICSSR, Govt. of India.

Mrs. Roy is life member of Geographical Society of India and Indian National Cartographic Association.

Mr. Dibyendu Chatterjee completed B.Sc. degree in Electronics (Hons.) and stood first class first (gold medalist) from Bankura Christian College (under Burdwan University, West Bengal, India) in 2006 and M.Sc. degree in Electronic Science from Jadavpur University (West Bengal, Kolkata, India) in 2008. He is also qualified prestigious examinations such as NET (National Eligibility Test, conducted by UGC govt. of India) and GATE (Graduate Aptitude Test in Engineering, conducted by IITs & IISc) in Electronics and Communication Engineering. Presently Mr. Chatterjee is pursuing Ph.D. at the Department of Electronics, West Bengal State University (Barasat, India). His main area of research is Quantum Computation.