

# An Aerodynamic Design and Analysis of Motor Cycle Helmet with Anti-Glare Visor

V. C. Sathish Gandhi, R. Kumaravelan, S. Ramesh, M. Venkatesan, M. Siva Rama Krishnan

**Abstract**—Motor cycle accidents have been increased for the past two decades. Helmet can protect the vehicle riders from severe injuries during road accident to certain extent. To design a functional helmet, it is important to analyze the shape of the helmet and visor portion. Hence, an attempt has been made for design and analysis of new helmet by considering the drag pressure and anti-glare visor. The drag pressure resistance presses the helmet against the neck portion of the rider. The shape of an aerodynamic helmet can be able to reduce the drag pressure. The spherical shape and a new aerodynamic shape helmets are designed with help of Pro-E software and the drag pressures were calculated and comparison has been made on the basis of drag pressure.

**Keywords**—Helmet, drag pressure, aero-dynamic, refractive index, Pro-E.

## I. INTRODUCTION

AS per the ‘Mechanism of head injury’, the data have been collected from US country shows that many persons lost their lives as they did not wear helmets. The results from various sectors indicate that riders were affected by neck pain in the spherical shape helmet and also in night time riding they could not impair vision through the visor in the helmet. Helmets must provide crash protection, adequate ventilation, and reduced aerodynamic drag. The aerodynamic drag resulting from surface friction is quite low compared to the resulting pressure drag. Therefore, the largest reductions in coefficient of drag can be achieved while the pressure drag is reduced by maintaining low drag co-efficient.

## II. LITERATURE REVIEW

Several studies have been conducted to evaluate the protective performance of helmets during direct head impact, with constant-rate compression and drop-impact tests which

Dr. V. C. Sathish Gandhi, Assistant Professor, is with the Department of Mechanical Engineering, University College of Engineering Nagercoil, Anna University: Tirunelveli Region, Konam, Nagercoil - 629004, Tamilnadu, India. (Phone: +91 9894500097, e-mail: vcsgandhi@gmail.com).

Dr. R. Kumaravelan, Professor and Head, is with the Department of Mechanical Engineering, Velalar College of Engineering and Technology, Erode - 638012, Tamilnadu, India.

Dr. S. Ramesh, Professor and Principal, is with the Department of Mechanical Engineering, Annai Mathammal Sheela Engineering College, Namakkal - 637013, Tamilnadu, India.

Mr. M. Venkatesan, Assistant Professor, is with the Department of Mechanical Engineering, University College of Engineering Nagercoil, Anna University: Tirunelveli Region, Konam, Nagercoil - 629004, Tamilnadu, India.

Mr. M. Siva Rama Krishnan, Under Graduate student, is with the Department of Mechanical Engineering, University College of Engineering Nagercoil, Anna University: Tirunelveli Region, Konam, Nagercoil - 629004, Tamilnadu, India.

are typically used to investigate the protective contribution of individual helmet components in [1]-[4]. In [5] the effectiveness of mandated motorcycle helmet use in Taiwan by applying logit modeling approach and before-and-after comparisons. In [6] the helmet design variations in terms of different variables other than headform linear acceleration and suggested that the model had optimized cost, weight and helmet size. The biomechanical characteristics of head impact with both metal form and ABS helmets and suggested that the metal form shell is performed well compared with ABS helmet [7]. In [8] the rotational and linear acceleration of a Hybrid II headform, representing a motorcyclist’s head, in such impacts, considering the effects of friction at the head/helmet and helmet/road interfaces by Finite element analysis. In [9] the simulation models of helmet and human head to study the impacts on a protected and unprotected head in a typical motorcycle related collisions. In [10] the simulation method is used to determine the velocity of air flow in the helmet models with Pressure and stresses in the brain. In [11] the head injuries by Finite element simulation are discussed. In [14] that during a long bicycle time trial or during the cycling portion of a triathlon, 80 to 90 percent of the power developed by the athlete is used to overcome aerodynamic drag. In [15] many of these events are won or lost by only seconds. Small reductions in overall aerodynamic drag can easily save seconds in any of these events, giving the athlete a decisive advantage. In [16] the helmets must provide crash protection, adequate ventilation, and reduced aerodynamic drag. In air at typical cycling speeds the Reynolds number for an aerodynamic helmet is in the range of 300,000 to 500,000. Reynolds numbers in this range show that the aerodynamic properties will be dominated by inertial effects. In [12] an experimental bird strike tests on aluminum foam based double sandwich panels. They predicted that the failure of structural components with aluminium foam in bird-strike events through a numerical model. In [13] investigation in a triple layer dielectric systems in which the reflection at the main contact surface is decreased due to the interference of the reflected light from each interface, so that the refractive index  $n(x)$  is an unknown piecewise constant function. The results from various sectors indicate the very high percentage injuries can be prevented by using helmet. Even though people wear helmet, due to its inadequate quality, the neck pain was developed and glare in the visor are high.

Finally, it is essential to produce standard helmet with proper aero-dynamic shape to reduce the neck pain of the rider in the long journey paraded with anti-glare in the visor. The

attempt has been made to design and analysis of aerodynamic shape helmet model by using 'Pro-E' software.

### III. MATERIALS AND METHODS

The standard spherical shape helmet model is created in the Pro-E software as per the dimensions shown in Fig. 1.

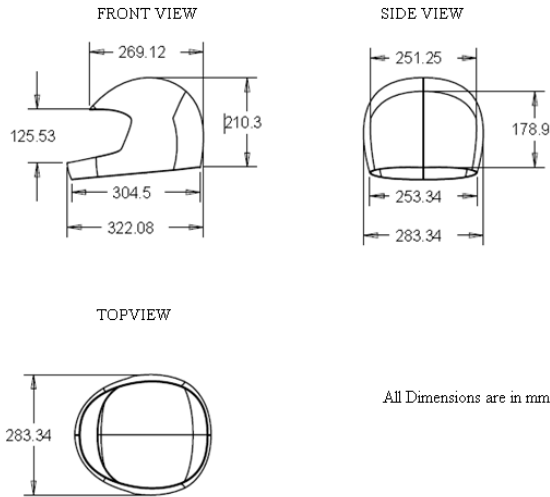

Fig. 1 Standard dimensions of various parts in helmet

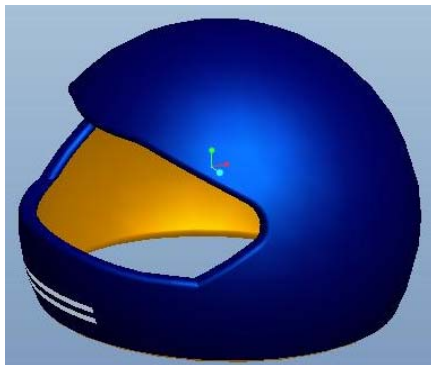

Fig. 2 Helmet CAD model

Fig. 2 shows the spherical shape helmet model developed in the Pro-E software. This model helmet has created more neck pain during long journey. So the attempt has been made for redesigning the helmet considering the aerofoil profile.

#### A. Selection of an Aerofoil Profile

The main type of drag acting against a cyclist is pressure drag. It is caused by the air particles being more compressed (pushed together) on the front-facing surfaces and more spaced out on the back surfaces. The drag force depends upon the various shapes and drags co-efficient.

TABLE I

DRAG COEFFICIENT VALUES FOR DIFFERENT AEROFOIL SHAPES

S. No.	Shape	Figure	Drag coefficient
1	Sphere		0.47
2	Half-sphere		0.42
3	Cone		0.50
4	Cube		1.05
5	Angled cube		0.80
6	Long cylinder		0.82
7	Short cylinder		1.15
8	Streamlined body		0.04
9	Streamlined half-body		0.09

Table I shows the measured drag coefficient values for the different aerofoil shapes. It is clearly shown that the streamlined body shape is having the low drag coefficient compared with other shapes. So this shape is chosen for redesigning the helmet for minimizing the drag force.

#### B. Redesign of Helmet

The spherical shape model helmet is redesigned with the new aerofoil shape of streamline body. Fig. 3 shows the redesign model of the helmet considering the aerodynamic concept. In the back side of the helmet, the streamline air flow is considered and the shape has been modified to reduce the drag coefficient.

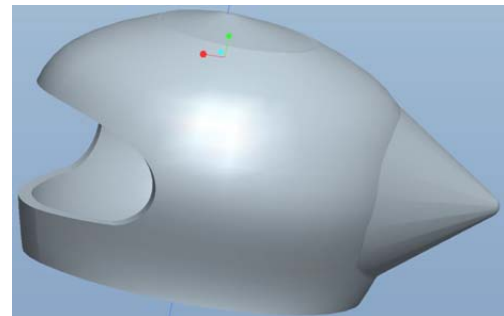

Fig. 3 Redesign helmet (Streamline shape)

#### C. Drag Pressure

The drag force is estimated for the spherical shape helmet model from (1):

$$F_d = 0.5 \times V \times \rho \times C_d \times A \quad (1)$$

where,

- $F_d$  = Drag force in N
- $V$  = Velocity of air in m/s
- $\rho$  = Density of air in  $\text{kg/m}^3$
- $C_d$  = Drag coefficient
- $A$  = Frontal area of helmet in  $\text{m}^2$

$$\text{Drag Pressure (D}_p\text{)} = \text{Drag force} / \text{Frontal area of helmet} \quad (2)$$

The drag pressure is estimated from (2) for the specifications considered in the spherical shape helmet model.

*D. Refractive Index in the Visor without Coating*

The reflection from any given interface at normal incidence is related to the ratio of refractive index of the materials forming the interfacing and has characteristics by % of reflectance. In optics, the refractive index or index of refraction (n) of a substance (optical medium) is a dimensionless number that describes how light, or any other radiation, propagates through the medium.

$$\text{Refractive index, } n = \frac{C}{V} \quad (3)$$

where, C is the speed of light in vacuum and V is the speed of light in the substance.

The percentage of reflectance through the visor is calculated from (4):

$$2 \left[ \frac{(n_o - n_s)^2}{(n_o + n_s)^2} \right] \times 100 \quad (4)$$

where,  $n_o$  is the refractive index of the first layer (air) and  $n_s$  is the refractive index of the second layer (window).

Thus, for a crown glass window,  $n_o = 1$  and  $n_s = 1.52$  giving a reflectance at normal incidence of 4.3% per surface, i.e. a total reflectance of 8.6% from the window. In order to minimize or remove this reflectance, completely a further layer of refractive index ( $n_1$ ) is coated onto the window such that reflections from the air/coating and coating/window interfaces undergo destructive interference to the greatest possible extent.

IV. RESULTS AND DISCUSSION

The drag pressure and the coefficient of drag are estimated from (1) and (2) for the streamline shape of the redesign helmet with the following specification

Frontal area of helmet = 0.08 m<sup>2</sup>

Velocity of air = 22.2 m/s

Density of air = 1.22 kg/m<sup>3</sup>

Drag co-efficient = 0.47

$$\begin{aligned} \text{Drag force (F}_d) &= 0.5 \times 22.2 \times 0.47 \times 1.22 \times 0.08 \\ &= 0.509 \times 9.81 \\ &= 5N \end{aligned}$$

Therefore, Drag pressure ( $D_p$ ) = 5 / 0.080 = 62.43 N/m<sup>2</sup>

From these calculations, the drag pressure value is estimated at 62.43 N/m<sup>2</sup> in the spherical shape helmet model. The attempt has been made to estimate the drag pressure for the modifying streamline shape helmet. The drag pressure value depends on the drag coefficient of the aerofoil shape. The drag coefficient value for streamline shape is 0.04. From (1) and (2), the drag pressure ( $D_p$ ) is estimated for streamline shape helmet is 5.775 N/m<sup>2</sup>.

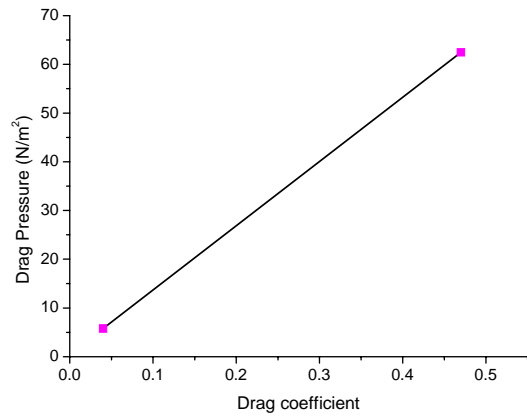

Fig. 4 Drag coefficient Vs Drag Pressure

Fig. 4 shows the relationship between drag coefficient and drag pressure. It is clearly shown that if drag pressure increases with increase in the drag coefficient. The neck pain for the rider increases with respect to increase in the drag pressure. Consequently, it is identified that the streamline shape model helmet reduces the neck pain for the rider in the long time journey compared with spherical shape model helmet.

*A. Anti Glare Visor - Percentage of Reflection with Coating*

The percentage of radiation glare through the polymer coating is estimated from (4). In this equation  $n_o$  is replaced as  $n_x$ . where,  $n_x$  is high refractive index to the polymer coating it is equal to 1.97.

$$\begin{aligned} \text{Percentage of reflection through the visor with coating} \\ &= 2 \left[ \frac{(1.97 - 1.52)^2}{(1.97 + 1.52)^2} \right] 100 \\ &= 33.3\% \end{aligned}$$

Comparison of percentage of reflection has been made between with and without coating from the visor portion to resist the glare penetrate to the rider eye. Difference in reflection percentage = 33.3 - 8.6 = 24.7 %

The polymer coating reduces the headlight glare of 24.7%. So that the visor is made of polymer coating reduces the glare of the rider from the lighting source.

V. CONCLUSION

The design of a helmet shape has been carried out by streamlined shape with anti-glare visor. The study has been made for two different aspects. In the first case, an aerodynamic shape has been considered and in the next case the hybrid high refractive index coating in the visor has been studied. The results show that the streamline shape of a helmet is having low drag pressure and reduces the neck pain of the rider for long traveling. The visor portion of a helmet is coated with polymer and it reduces the refractive index of the visor. This polymer coating reduces the glare of 24.7% compared with non coated visor and eliminate the opposite headlight glare for the night time riders.

REFERENCES

- [1] Kingsbury, H. B., and Rohr, P. R., "Structure Characteristics of Motorcycle Helmets", *Paper No. 810372, Society of Automotive Engineers, Inc*, 1981.
- [2] Gale, A., and Mills, N. J., "Effect of Polystyrene Foam Liner Density on Motorcycle Helmet Shock Absorption", *Plastics and Rubber Processing and Applications*, vol. 5, no. 2, pp. 101-108, 1985.
- [3] Mills, N. J., and Gilchrist, A., "The Effectiveness of Foams in Bicycle and Motorcycle Helmets", *Accident Analysis and Prevention*, vol. 23, no. 2-3, pp. 153-163, 1991.
- [4] Gilchrist, A., and Mills, N. J., "Impact Deformation of ABS and GRP Motorcycle Helmet Shells", *Plastics and Rubber Processing and Applications*, vol. 21, 3, pp. 141-150, 1994a.
- [5] Chang, L. Y., "Empirical analysis of the effectiveness of mandated motorcycle helmet use in Taiwan", *Journal of the Eastern Asia Society for Transportation Studies*, vol. 6, pp. 3629 - 3644, 2005.
- [6] Rueda, M. A. F., and Gilchrist, M. D., "Computational analysis and design of components of protective helmets", *Proceedings of the Institution of Mechanical Engineers, Part P: Journal of Sports Engineering and Technology*, vol. 226, no. 3(4), pp. 208-219, 2012.
- [7] Praveen, K., Pinnoji, P. K., Bourdet, N., Mahajan, P., Willinger, R., "New motorcycle helmets with metal foam shell", *IRCOBI Conference proceedings-Bern(Switzerland)*, pp. 449 - 452, 2008
- [8] Mills, N.J., Wilkes, S., Derler, S., Flisch, A., "FEA of oblique impact tests on a motorcycle helmet", *International Journal of Impact Engineering*, vol. 36, 913 - 925, 2009.
- [9] Toma, M., Njilie, F. E. A., Ghajari, M., Galvanetto, U., "Assessing motorcycle crash-related head injuries using Finite Element simulation", *Int. J. simul model*, vol. 9, pp. 143 - 151, 2010.
- [10] Pinnoji, P. K., and Mahajan, P., "Impact analysis of helmets for improved ventilation with deformable head-model", *IRCOBI Conference - Madrid (Spain)*, pp. 159 - 170, 2006.
- [11] Afshari, A., and Rajaai, S. M., "Finite element simulations investigating the role of the helmet in reducing head injuries", *International Journal of Simulation modelling*, vol. 7, no. 1, pp. 42 - 51, 2008.
- [12] Hanssen, A. G., Girard, Y., Olovsson, L., Berstad, T., Langseth, M., "A numerical model for bird strike of aluminium foam-based sandwich panels", *Int. J. of Impact Engg.*, 32, pp. 1127-1144, 2005.
- [13] Nubile, P., "Analytical design of antireflection coatings for silicon photovoltaic devices", *Thin Solid Films*, vol. 342, pp. 257-261, 1999.
- [14] Alam, F., Subic, A., Akbarzadeh, A., "Aerodynamics of Bicycle Helmets", *The Engineering of Sport*, vol. 7, no. 1, pp. 337-334, 2008.
- [15] Blair, K., and Sidelko, S., "Aerodynamic Performance of Cycling Time Trial Helmets", *The Engineering of Sport*, vol. 7, no. 2, pp. 371-377, 2008.
- [16] Wilson, D., "Bicycling Science, 3rd ed. Cambridge, MA: Massachusetts Institute of Technology, pp. 110-120 and 174-205, 2004.