

A Novel Model for Simultaneously Minimising Costs and Risks in Just-in-Time Systems Using Multi-Backup Suppliers: Part 2- Results

Faraj El Dabee, Romeo Marian, Yousef Amer

Abstract—This paper implements the inventory model developed in the first part of this paper in a simplified problem to simultaneously reduce costs and risks in JIT systems. This model is developed to ascertain an optimal ordering strategy for procuring raw materials by using regular multi-external and local backup suppliers to reduce the total cost of the products, and at the same time to reduce the risks arising from this cost reduction within production systems. A comparison between the cost of using the JIT system and using the proposed inventory model shows the superiority of the use of the inventory model.

Keywords—Lean manufacturing, Just-in-Time (JIT), production system, cost-risk reduction, inventory model, eternal supplier, local backup supplier.

I. INTRODUCTION

IN today's competitive global markets, customers seek to obtain their requirements with a high quality, and at the same time at the cheapest prices, regardless of the places where are produced in. This will lead organisations to implement new techniques, in order to reduce the costs of their products and to insure their positions in the marketplace [1]. Lean manufacturing is a philosophy, which can be used to assist production systems to reduce their wastes, and to increase the activities that add value from the customer's viewpoint [2]. The basis of which is simple concepts through which it has gained wide popularity. By understanding these concepts and principles, lean manufacturing can be understood easily [3].

The main task of the lean manufacturing system is to locate the major sources of waste which would then be eliminated by the application of a large number of tools such as JIT and production smoothing [2]. JIT is considered as one of the significant lean manufacturing tools that can be used within

Faraj El Dabee is a PhD student at the School of Advanced Manufacturing and Mechanical Engineering, Division of Information Technology, Engineering and the Environment, University of South Australia, Mawson Lakes, 5095 Australia (phone: +61883023112; e-mail: eldfy001@mymail.unisa.edu.au).

Dr. Romeo Marian is a Senior Lecturer and Program Director at the School of Advanced Manufacturing and Mechanical Engineering, Division of Information Technology, Engineering and the Environment, University of South Australia, Mawson Lakes, 5095 Australia (phone: +61883025275; e-mail: romeo.marian@unisa.edu.au).

Dr. Yousef Amer is a Program Director and Academic Integrity Officer at the School of Advanced Manufacturing and Mechanical Engineering, Division of Information Technology, Engineering and the Environment, University of South Australia, Mawson Lakes, 5095 Australia (phone: +61883023006; e-mail: Yousef.Amer@unisa.edu.au).

organisations leading to improvement on a continuous basis including the material flow and information, management of human resources, improved throughputs, costs reduction, and elimination of wastes and non-value added activities [4].

Most international organisations have implemented lean manufacturing tools such as Just-in-Time (JIT) in their processes to reduce their costs and to improve their efficiencies. However, they ignored the risks arising from these goals. These risks will impact on their processes disrupting the whole supply chain.

The main objective of this paper is to implement the proposed model developed in the first part of this paper in a simplified example to reduce the costs of the final product and at the same time to reduce their effects in JIT systems risks arising from these benefits within the production system to determine an optimal ordering strategy for obtaining raw materials within the production systems using both external and local backup suppliers in case of the occurrence of likely disruption such as natural and man-made disasters, and economic crises to achieve high product quality and total financial and operational actions within the supply chain.

This paper is organised as follows: Section II reviews some of the literature on JIT, and cost and risk modelling. In Section III, a simplified problem is provided to illustrate the application of the model developed in the first part of this paper. Section IV discusses the findings from implementing the developed model in the simplified problem. Finally, Section V summarises and concludes this paper.

II. LITERATURE REVIEW

Just-in-Time (JIT) is a Lean manufacturing tool that can be utilised to improve organisations' efficiency. It is a manufacturing pull system, which can be used for planning and controlling operations, in order to produce, and supply the required products at the correct place, when they are required, and at the right ordered amounts [5], [6]. Some critical principles such as high quality, small lot sizes, and regular deliveries in short lead times, close contact with suppliers are included during this philosophy [7]. The appropriate use of JIT in manufacturing can reduce waste and increase productivity, efficiency, profit, and customer satisfaction [8], [9].

Recently, researchers have searched for an economic quantity model of a production system following JIT approach for ordering raw materials and the shipping process. Different kinds of models can be utilised for the purpose of ensuring

reduction in the level of cost and risk in case of JIT systems. For instance, one such model type that can be utilised for achieving cost efficiency is the lot size reduction model. This model emphasizes that by ensuring reduction in the lot size, it can become possible to achieve a reduction with respect to the level of the cost required in performing the delivery of finished products to final consumers [10]. Yang [11] developed a model to investigate the design of profit-sharing incentive plans in the JIT production environment to achieve time and costs reduction by using agency theory and the Scanlon policies developed in the US. Fahimnia et al. [12] developed a mixed integer formulation for optimising a two-echelon supply network. They concluded that by implementing the developed model in a case study, it is clear that considering all production costs prove the effectiveness of this model in the real applications.

A global supply chain model has also been proposed to optimise the after tax profits of a multinational corporation, which include transfer pricing (TP) and the distribution of transportation costs as explicit decision variables based on the estimated inventory costs generated by using each transportation mode [13]. In their article, Kumar et al. [14] discuss optimal operating strategies for an international corporation conducting business in different countries. Many risk factors such as, late shipments, exchange rates, customs delays, quality control problems, logistics and transport breakdowns, and production risks have a significant impact on its strategies, which increase the total operation costs within the supply chain. For this reason, a model was developed to offer the optimal operational strategies for the supply chain based on the expected risks factors, in order to allocate order quantities between the supply chain parties to minimise the whole costs of the supply chain operation including supplier cost, production cost, warehouse related cost, and market cost. Lababidi et al. [15] also developed an optimization model for the petrochemical company supply chain operating under uncertain operating and economic conditions. This model was tested on a typical petrochemical firm, producing different grades of polyethylene, which was operating using two reactors at a single location, in order to reduce the total production costs and raw material procurement, demand losses, accumulation, transportation, and inventory penalization for each scenario. It is essential to define the optimum production lot size and the ordering quantities of associated raw materials together. These could be done treating the production and purchasing as components of a single system, minimizing the total cost of the system [16].

As systems become increasingly integrated, any disturbance cannot be arrested in the functional area of origin and propagated through the production and distribution system. The reduction of waste (muda), as inventory or extra production capacity, exposes adjacent activities and may affect the whole supply chain. In his article, Tomlin [17] investigates some features of the organisation, its supplier(s), and its products such as supplier reliability, and supplier failure correlation and their impacts on the organization's preference. Also, he mentions that common dual sourcing can

protect organisation from any disruption impacts due to receiving its delivery from both in case of one supplier has disruption. Simchi-Levi et al. [18] point out the risks associated with a JIT system in case of unforeseen disasters occurrence such as what actually happened to some auto manufacturers following Sept. 11, 2001. They emphasise that sharing risks during the whole supply chain parties has a significant impact on them. In addition, Gaivoronski et al. [19] present an approach for considering a cost-risk balanced process to manage the scarce water resources in conditions of uncertainty. A new technique relating to a re-optimization phase was modelled that allows users to organise emergency strategies by adopting the barycentric value as a new target, which resulted in drastic risk reduction of resources delivery. El Dabee et al. [20] developed a mathematical model to reduce the total cost of the products, and at the same time to reduce the risks arising from this cost reduction within production systems using external suppliers for supplying raw materials to the production systems. They concluded that comparing the use of a JIT system with the use of a specific amount of inventory during a limited period of time had a significant impact on the production system.

It is clear that risks have an adverse impact in organisations' performance, which leads them to increase their total costs and at the same time reduce their efficiency. Therefore, risks should be assessed by identifying, evaluating, and measuring them, in order to reduce their undesired effects within these organisations.

III. SIMPLIFIED EXAMPLE

The mathematical model proposed in part 1 has been tested with a simple assembly process for a brushless DC electric motor (BLDC). It uses multiple, identical operations to assemble six individual parts M_i into the finished product ($N_p=6$) namely, magnets, shaft, stator, hall sensors, bearing, and end bells. It is assumed that a production system purchases raw materials in a fixed size from three different regular external suppliers ($N_s=3$). These raw materials are delivered at a fixed interval of time when they are needed (JIT system). Parts 1 and 2 are supplied by the supplier S_1 , which need four weeks (LT) to arrive, parts 3 and 4 are supplied by the supplier S_2 , which require six weeks to arrive, and Parts 5 and 6 are supplied by the supplier S_3 , which take five weeks to arrive. The production system includes four operations conducted by four workers (W_1, W_2, W_3 , and W_4 respectively). The number of working hours N_h is 7 hours a day during 5 days per week, each worker has a fixed wage C_{w_i} valued 15 monetary unit (MU)/ hour. Operation 1 assembles parts 1 and 2 and transfers them to operation 2, which assembles parts 3 and 4, and then transfers them to operation 3. Operation 3 assembles parts 5 and 6, and finally transfers the product to operation 4, which tests and keeps the final product in boxes and then sends it to the sales department. It is assumed that the utilities cost C_U is equal to 10% of the raw material cost of the final product. Furthermore, it is assumed that the raw materials cost from the local backup supplier S_{LB} equals 150% of their cost when they are purchased from the regular suppliers S_E .

Finally, the end customer purchases the final product by 75 MU. Fig. 1 shows the supply chain for this production system.

In order to avoid any lack of production, the purchased quantities are assumed to be higher than the required demand rate of the finished products. The production facility produces 60 units/ day, and it purchases raw materials from the three different regular external suppliers S_E (if no disruption occurs) and local backup supplier S_{LB} (when one or more of the regular suppliers are disrupted). Each order is 1320 units from parts 1 and 2, 1980 units from parts 3 and 4, and 1650 units from parts 5 and 6 respectively. These order quantities can meet customer needs during a fixed interval of time in normal situations. However, many risks result from a time delay for the arrival of these materials to the production system on time that arise from many risk factors such as physical, social, legal, operational, economic and political factors. These factors can affect and disrupt the production system and all the supply chain parties. Therefore, this paper studies the effects of these factors on the production facility as a case study.

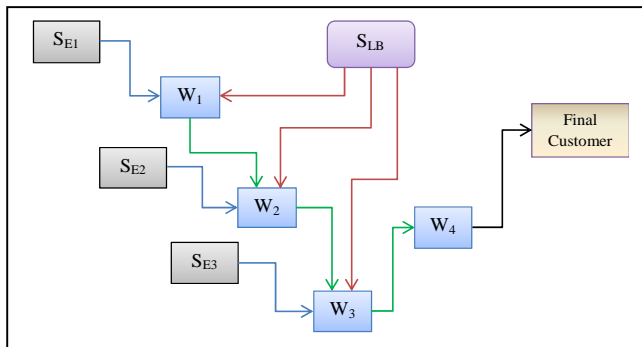

Fig. 1 The supply chain for the production system

TABLE I
 RISK ASSESSMENT OF THE BLDC MOTOR IN PRODUCTION SYSTEM

Risk Symbol	Risk	Product Effect	Likelihood (1 - 5)	Impact (1 - 5)	% Total Risk Score
H_1	External supplier 1 cannot supply raw materials on the scheduled time.	All product	2	2	$\frac{4}{25} = 16\%$
H_2	External supplier 2 cannot supply raw materials on the scheduled time.	All product	2	4	$\frac{8}{25} = 32\%$
H_3	External supplier 3 cannot supply raw materials on the scheduled time.	All product	2	3	$\frac{6}{25} = 24\%$

The main cost drivers in a BLDC motor are: magnets, shaft, stator, hall sensor, bearings, and end bells. They are shown in Table II as a percentage rate of the total cost of the motor.

This table also illustrates the cost percentage rate, incurred duties, and transfer price for each supplier.

TABLE II
 COST DRIVERS IN BLDC MOTOR

Supplier	Raw material type	Cost percentage (%)	% Supplier rate	% Duties rate	% Transfer price (TP)
S_1	Magnets	20	30%	4%	2.5%
	Shaft	10			
S_2	Stator	25	37%	3%	2%
	Hall sensor	12			
S_3	Bearing	15	33%	5%	3%
	End bells	18			

According to the model equations in the first part of this paper, the total final product costs of a BLDC motor using a regular external and a local backup supplier can be calculated.

Therefore, C_T can be calculated in case of using the regular external supplier for procuring raw materials as follows:

$$C_T = \sum_{i=1}^{N_p} C_{O_i} + \sum_{i=1}^{N_p} C_{UH_i} + \sum_{i=1}^{N_p} C_{UM_i} + t_m \times \sum_{j=1}^{N_s} T_{Sj,V,m} + \sum_{i=1}^{N_p} \sum_{j=1}^{N_s} C_{M_i} (1 - IF_j) \times D_j + \sum_{i=1}^{N_p} \sum_{j=1}^{N_s} C_{M_i} (1 + t_{p_j}) \times C_{M_i} + \sum_{i=1}^{NO} C_{L_i} \times h_i + \sum_{i=1}^{N_p} \% C_{M_i} + \sum_{i=1}^{N_p} (LH \times I / \text{Max}(LH \times I)) \times C_{M_i} \quad (1)$$

Also, when raw materials are supplied by the local backup supplier, C_T can be found as:

$$C_T = \sum_{i=1}^{N_p} C_{O_i} + \sum_{i=1}^{N_p} C_{UH_i} + \sum_{i=1}^{N_p} C_{UM_i} + t_m \times \sum_{j=1}^{N_s} T_{Sj,V,m} + \sum_{i=1}^{NO} C_{L_i} \times h_i + \sum_{i=1}^{N_p} \% C_{M_i} + \sum_{i=1}^{N_p} (LH \times I / \text{Max}(LH \times I)) \times C_{M_i} \quad (2)$$

where,

- C_T : Total cost required to produce one product in monetary unit (MU);
- C_O : Ordering cost of raw materials (MU);
- C_{UH} : The cost that is carried per unit during each cycle (MU);
- C_{UM} : Unit cost of the raw material at the beginning of that cycle (MU);
- t_m : Critical transportation measurement of raw materials shipped using transportation mode m ;
- $T_{S, n, m}$: Tensor for transportation cost per critical measurement (MU);
- C_M : Raw material cost required for producing one product (MU);

IF : Indicator function for duty with a value 1 or 0. 1 if the supplier and the production facility are in the same country and 0 otherwise;

D_j : Duty rate (%) per price of raw material i supplied by an external supplier j (MU);

tp : The percentage rate of raw material cost (MU);

C_{L_i} : Labour cost rate per labour time in operation i (MU/hr);

h_i : Operation time required to produce a product i (hr);

LH : Likelihood of occurrence for risk in the supply chain;

I : Impact of risk occurrence in the supply chain;

N_p : Number of parts required to produce one product (unit);

N_s : Number of external suppliers required to supply raw materials to the production system (unit); and

N_O : Number of operations required for producing one product (unit);

IV. RESULTS AND DISCUSSION

In this section, the proposed model will be used to ascertain the decision variables effect on other studied parameters within the production system. The findings of this paper are organised in three cases as follows:

1. Case I:

The impact of lead time on cost types of final product will be investigated for a scenario of having disruption from an external supplier. This prompts sufficient stock keeping from the external supplier to prevent any likelihood of stock running out.

The findings illustrates in Fig. 2 show that if the supplier 1 has disruption for any reason, keeping different amount of raw materials supplied by the regular external supplier in warehouses (1- 6 weeks) have direct impact on the total cost arising from the risk cost associated with the supplier. Relatively, keeping raw materials in the warehouses have high impact on the earned profit. Fig. 2 shows increase in the utilities and risk costs, whereas the purchasing cost decreases. However, the ordering, transportation, duties, transfer price, and worker costs are fixed. Surprisingly, the figure shows that the safety stock amount for 1- 6 weeks give a negative profit rate.

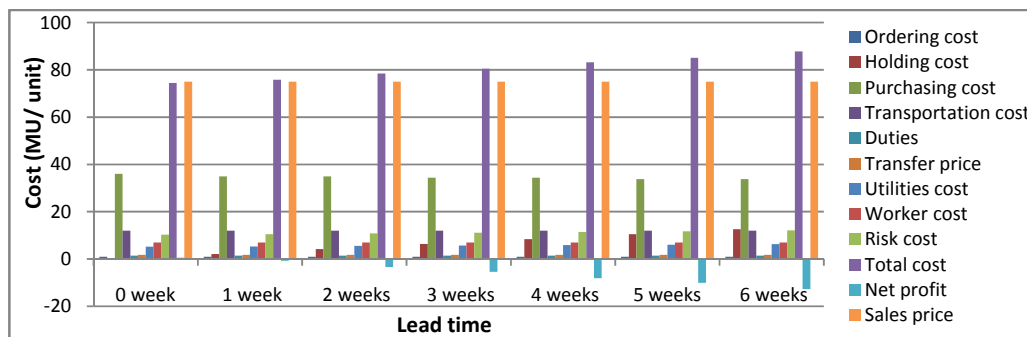

Fig. 2 Lead time and its impact on cost types arising from supplier 1 disruption

Fig. 3 shows that if any disruption affects supplier 2 who supplies some amount of raw material types used for production, then keeping safety stock of these raw materials in

warehouses (1- 6 weeks) at different periods of lead time have a direct impact on all related costs.

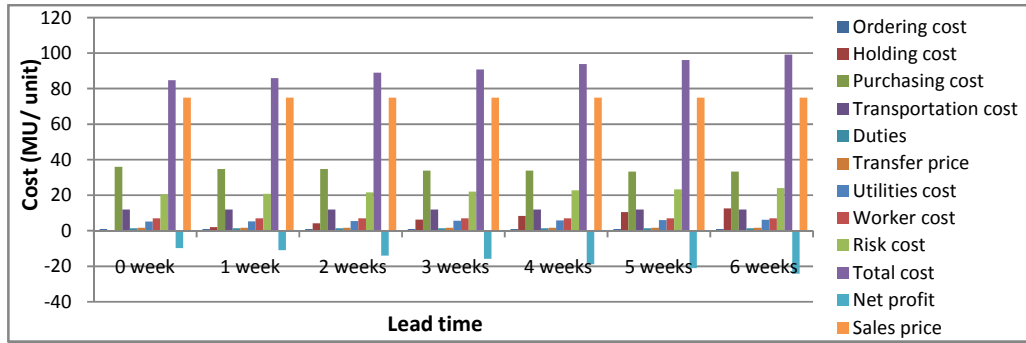

Fig. 3 Lead time and its impact on cost types arising from supplier 2 disruption

From Fig. 4, it is clear that there is a striking impact on the total production cost, when supplier 3 is disrupted. This is because of the impact of the supplier risk cost arising from this disruption.

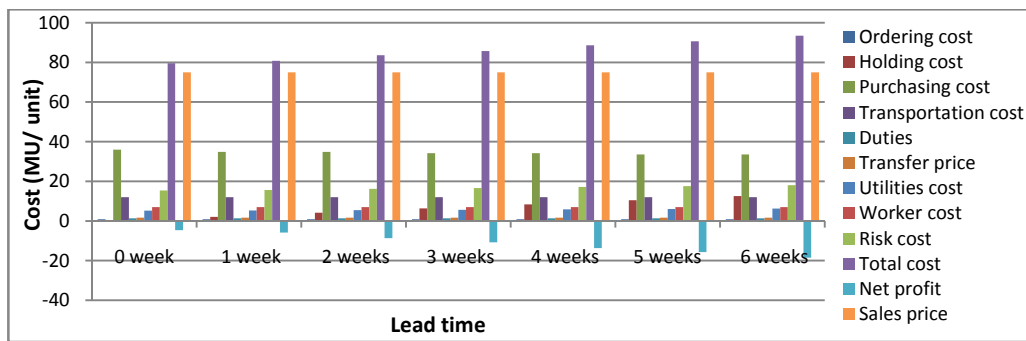

Fig. 4 Lead time and its impact on cost types arising from supplier 3 disruption

2. Case II:

Keeping the same base case as the first, the impact of lead time on cost types of final product will be investigated where stock is procured from local backup supplier. This case assumes that the external supplier is not able to meet supplier demand due to the disruption.

By using local backup supplier for supplying the required raw material in the event of any disruption occurring from the

three external suppliers, stoppage of production that is caused by the lack of raw materials can be easily avoided. However, this will increase the purchasing and risk cost that depends on the reliability of these suppliers. Fig. 5 shows the effects of lead time on the total cost arising from the disruption caused by supplier 1. This prompts the use of local backup supplier to supply the required amounts of raw materials in different periods of lead time.

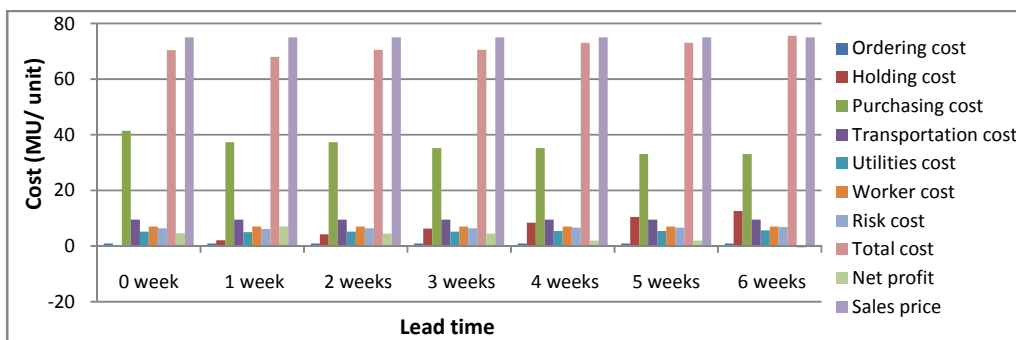

Fig. 5 Lead time and its impact on cost types arising from supplier 1 disruption using local backup supplier

Fig. 6 also illustrates the lead time impact on the total cost arising from the disruption caused by supplier 2. This prompts the use of local backup supplier to supply the required amounts of raw materials in different periods of lead time.

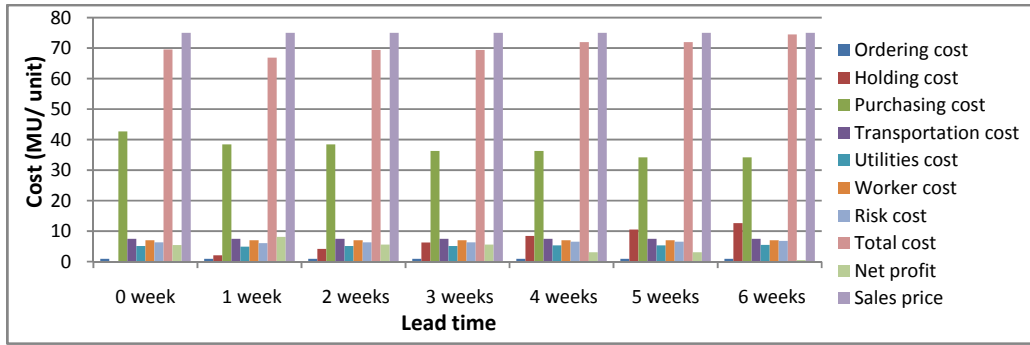

Fig. 6 Lead time and its impact on cost types arising from supplier 2 disruption using local backup supplier

In Fig. 7, it is clear that the lead time has marked impact on the total cost arising from the disruption occurring from

supplier 3 if the local backup supplier is used to supply the required amount of raw materials in different periods.

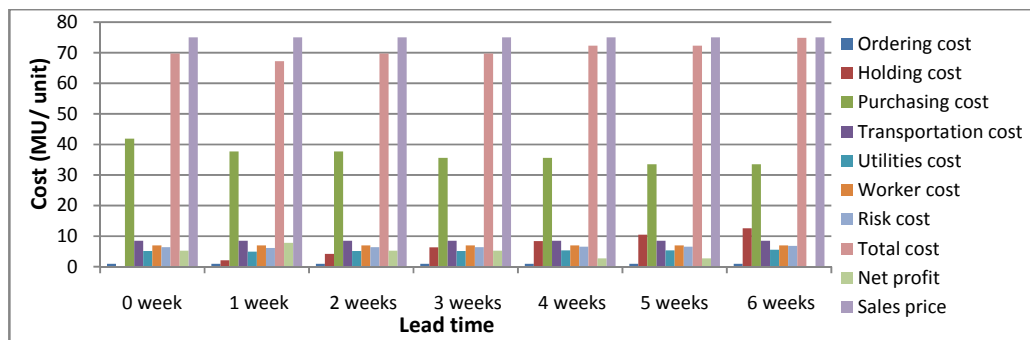

Fig. 7 Lead time and its impact on cost types arising from supplier 3 disruption using local backup supplier

3. Case III:

In this case, the two cases are compared to find the optimum quantity of required raw materials that give an appropriate profit during the disruption period.

Fig. 8 illustrates the comparison between the total costs of producing final product if disruptions occur from supplier 1. This compares the case of solely relying on an external

supplier or using local backup supplier. It can be observed that if supplier 1 has disruption, the cost arising from keeping inventory during this time using local supplier is less than the cost using the same supplier. Therefore, it can be observed that working with a 3 weeks inventory from a local backup supplier during the disrupted time gives a reasonable profit for the production system.

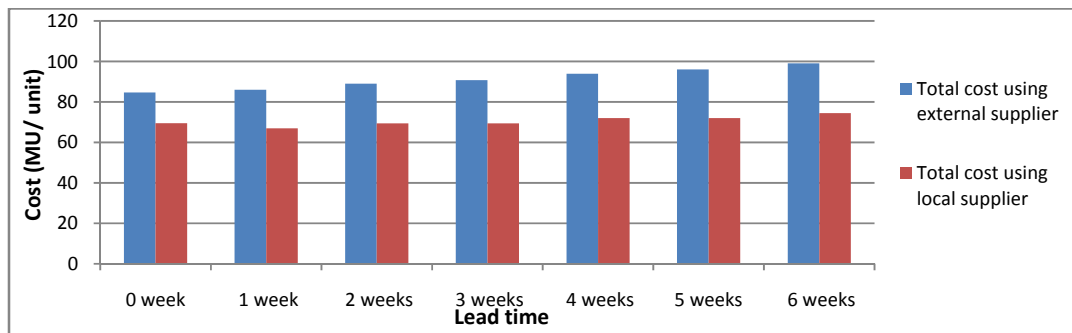

Fig. 8 Comparison between total cost arising from supplier 1 disruption using the disrupted supplier and local backup supplier

Fig. 9 illustrates a similar comparison for the case of supplier 2 and a local backup supplier. It is clear that if supplier 2 is disrupted, the cost arising from keeping inventory

during this time using local supplier is also less than the cost using the same supplier.

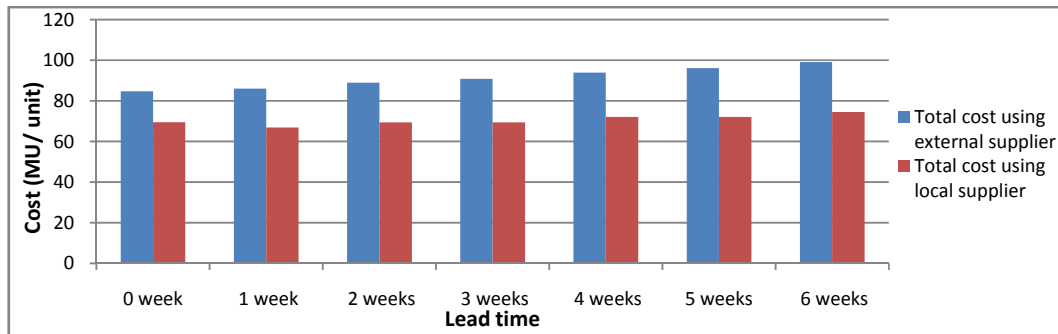

Fig. 9 Comparison between total cost arising from supplier 2 disruption using the disrupted supplier and local backup supplier

The same result has been found in case of supplier 3 is disrupted for supplying raw materials to the production system. Fig. 10 shows that by comparing the total cost arising from keeping safety stock amount within the production

facility using the regular external supplier and local backup supplier, the cost arising from keeping inventory during this time using local supplier is also less than the cost using the same supplier.

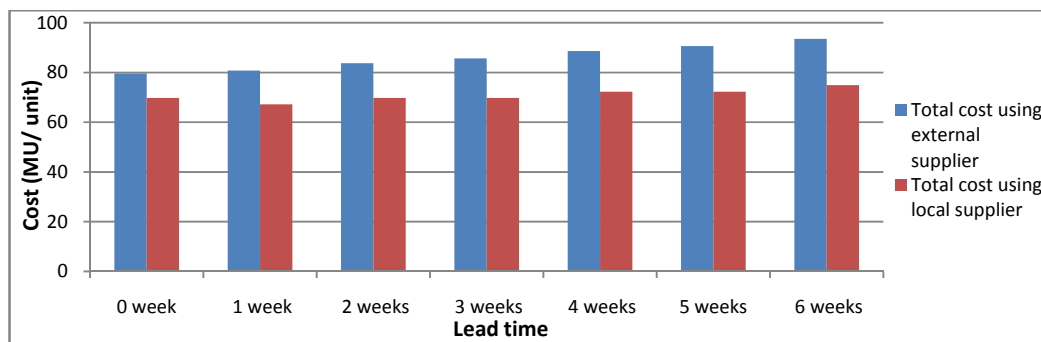

Fig. 10 Comparison between total cost arising from supplier 3 disruption using the disrupted supplier and local backup supplier

V. CONCLUSION AND FURTHER RESEARCH

This paper introduced the mathematical model developed in the first part of this paper for simultaneously reducing the cost and risk in JIT systems. It was developed to determine an optimal policy for procuring raw materials within the production systems by using regular multi-external and a local backup suppliers in case of the occurrence of likely disruption such as natural and man-made disasters, and economic crises. By implementing the model in a simplified example, it is concluded that comparing the use of a JIT system with the use of a specific amount of inventory during a limited duration had a significant impact on the production facility especially, by using the local backup supplier during the disruption time. This means that by using JIT, the production system will be stopped completely. However, by keeping a sufficient inventory, the production system can produce its final products but with a limited profit. Thereby JIT principles can be effectively applied for satisfying customer requirements at a minimum inventory cost with a minimum level of risk.

Due to the randomness, which is mostly inherent in application of supply chain management components such as transportation and lead time and other parameters, it seems that the developed mathematical model cannot well address such nature in supply chain management systems. Based on that, using simulation model as a validated tool to describe the dynamic nature of supply chain management system, it

markedly will be essential in calculating the output of supply chain management systems. Hence, the authors plan to consider this point of view in future research where a simulation modelling will be deployed to find the outputs of some components of supply chain management system. This will enhance the level of model accuracy as an abstract of real application systems.

REFERENCES

- [1] C.Caneland B. M.Khumawala, "International facilities location: a heuristic procedure for the dynamic uncapacitated problem," *International Journal of Production Research*, vol. 39, pp. 3975-4000, 2001.
- [2] F.Abdullah, "Lean Manufacturing Tools and Techniques in the Process Industry with a Focus on Steel," PhD thesis, University of Pittsburgh, 2003.
- [3] A.Badurdeen, "What is Lean Manufacturing?," 2006,[Online], Available:http://www.learnleanblog.com/2006/12/what-is-lean-manufacturing.html [Accessed 07.11.2011].
- [4] Y.Monden, *Japanese Cost Management*. World Scientific, 2000.
- [5] T. C. E. Chengand S.Podolsky, *Just-in-time manufacturing: an introduction*. New York, Chapman & Hall, 1996.
- [6] R. A.Hokoma, M. K.Khan and K.Hussain, "The Present Status of Quality and Manufacturing Management Techniques and Philosophies within the Libyan Iron and Steel Industry," *TQM Journal*, vol. 22, no. 2, pp. 209-221, 2010.
- [7] Z. X. Chen andB. R. Sarker, "Multi-vendor integrated procurement-production system under shared transportation and just-in-time delivery system," *The Journal of the Operational Research Society*, vol. 61, pp. 1654-1666, 2010.

- [8] Y.Li, K. F.Man, K. S.Tang, S. Kwong and W. H.Ip, "Genetic algorithm to production planning and scheduling problems for manufacturing systems," *Production Planning & Control*, vol. 11, no. 5, pp. 443-458, 2000.
- [9] T.Tourki, "Implementation of Lean within the Cement Industry," PhD thesis, De Montfort University, 2010.
- [10] J. S. Yang and J. C. H.Pan, "Just-in-Time Purchasing: an Integrated Inventory Model Involving Deterministic Variable Lead Time and Quality Improvement Investment," *International Journal of Production Research*, vol. 42, no. 5, pp. 853-863, 2004.
- [11] Y. H.Yang, "Setup Cost Improvement in Just-in-Time Production Using Profit Sharing," *Production Planning & Control*, vol. 12, no. 4, pp. 345-352, 2001.
- [12] B.Fahimnia, L.Luongand R.Marian,"An integrated model for the optimisation of a two-echelon supply network,"*Journal of Achievements in Materials and Manufacturing Engineering*, vol. 31, pp. 477-484, 2008.
- [13] C. J. Vidal and M.Goetschalckx, "A Global Supply Chain Model with Transfer Pricing and Transportation Cost Allocation,"*European Journal of Operational Research*, vol. 129, pp. 134-158, 2001.
- [14] S. K.Kumar, M. K. Tiwari and R. F.Babiceanu, "Minimisation of Supply Chain Cost with Embedded Risk Using Computational Intelligence Approaches," *International Journal of Production Research*, vol. 48, no. 13, pp. 3717-3739, 2010.
- [15] H. M. S.Lababidi, M. A.Ahmed, I. M. Alatiqi and A. F.AL-Enzi, "Optimizing the Supply Chain of a Petrochemical Company under Uncertain Operating and Economic Conditions,"*Industrial & Engineering Chemistry Research*, vol. 43, no.1, pp. 63-73, 2004.
- [16] R. A.Sarker and L. R.Khan, "An Optimal Batch Size for a Production System Operating under Periodic Delivery Policy,"*Computers & Industrial Engineering*, vol. 37, pp. 711-730, 1999.
- [17] B. Tomlin, "Disruption-Management Strategies for Short Life-Cycle Products," *Naval Research Logistics*, vol. 56, pp. 318-347, 2009.
- [18] D.Simchi-Levi, L. Snyder and M. Watson, "Strategies for Uncertain Times. Supply chain Management Review," 2002, [Online]. Available: <http://www.lehigh.edu/~lvs2/Papers/SCMR.pdf> [Accessed 06 November 2012].
- [19] A. A.Gaivoronski, G. M.Sechi and P.Zuddas, "Balancing Cost-Risk in Management Optimization of Water Resource Systems under Uncertainty,"*Physics and Chemistry of the Earth*, vol. 42-44, pp. 98-107, 2012.
- [20] F. El Dabee, R. Marian and Y. Amer, "An Optimisation Model for a Simultaneous Cost-Risk Reduction in Just-in-Time Systems," in the 11th Global Congress on Manufacturing and Management, *GCMM2012*, Auckland, New Zealand, 2012, pp. 190-201.
- [21] D. Bogataj and M.Bogataj, "Measuring the Supply Chain Risk and Vulnerability in Frequency Space,"*International Journal of Production Economics*, vol. 108, no. 1, pp. 291-301, 2007.