

Analysis and Experimentation of Interleaved Boost Converter with Ripple Steering for Power Factor Correction

A. Inba Remy, R. Seyezhai

Abstract—Through the fast growing technologies, design of power factor correction (PFC) circuit is facing several challenges. In this paper, a two-phase interleaved boost converter with ripple steering technique is proposed. Among the various topologies, Interleaved Boost converter (IBC) is considered as superior due to enriched performance, lower ripple content, compact weight and size. A thorough investigation is presented here for the proposed topology. Simulation study for the IBC has been carried out using MATLAB/SIMULINK. Theoretical analysis and hardware prototype has been performed to validate the results.

Keywords—Interleaved Boost Converter (IBC), Power Factor Correction (PFC), Ripple Steering Technique, Ripple, and Simulation.

I. INTRODUCTION

A vital factor for any structure is the front-end AC to DC converter. The input supply voltage which is in AC is rectified to a controlled DC, and also power factor correction purpose is attained. As per the investigation, the size of the filter can be made compact by correctly selecting the number of phases and the switching frequency. Interleaving decreases the entire input and output current ripples [1]. The total magnetic element size and weight can be minimized with the help of coupling inductor.

Due to the reduced ripple current in the supply side, power supplies with high efficiency power factor correction are extremely suggested. The power factor correction with zero-ripple input current is very attractive because it eliminates the filter in supply side thereby obtaining ripple free power in the ac line. This reduces the heaviness and increases the power density of the converter. The above said can be achieved by means of the coupled inductor, such as, modified interleaved boost converter. A modified boost converter with a coupled inductor is otherwise called as ripple steering technique which is also identified as Coupled magnetic filters technique.

A. Inba Remy is with the Department of Electrical and Electronics, Loyola – ICAM college of Engineering and Technology, Chennai, TamilNadu, India (e-mail: inbacruz@gmail.com).

Dr. R. Seyezhai is with the Department of Electrical and Electronics, SSN college of Engineering, Kalavakkam, TamilNadu, India (e-mail: seyezhair@ssn.edu.in).

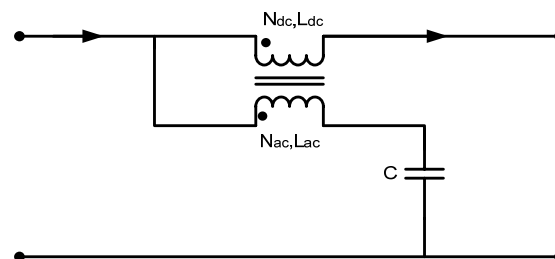

Fig. 1 Coupled inductor with smoothing capacitor

This method is applied to many topologies but the best identified topology is interleaved boost converter. In this technique, uncoupled inductor is replaced by a coupled inductor and an obstructive capacitor or blocking capacitor as shown in Fig. 1. Ripple steering for PFC boost converters has been presented in this paper. The ripple-steering technique has several advantages in a PFC boost converter [2], [3]. Subsequently it removes most of the differential-mode conducted noise; it supports the reduction in filter size and complexity, especially in its differential filtering unit, which contains capacitors and differential mode inductors. With ripple steering, the control strategy for the PFC stage is similar to that of a conventional boost converter, but the power stage transfer functions are different. This paper proposes a model to verify the effect of the added coupled filter.

II. INTERLEAVED BOOST CONVERTER WITH RIPPLE STEERING TECHNIQUE

The planned zero ripple PFC topology composed of two windings of coupled inductor and one capacitor as smoothing capacitor. Coupled magnetic filter techniques, identified also as ripple steering technique [4], have been applied to different topologies. Care is given to the application of ripple steering to PFC boost topology here. Fig. 2 shows the modified PFC boost converter. Replacing the inductors in a traditional boost converter with the coupled inductor and a blocking capacitor shown in Fig. 2 will result in a modified boost converter with ripple steering technique. The working of the circuit can be explained as follows: It permits the DC component of the input current to pass through the series winding at the input, the high frequency ripple component is filtered by routing it through the added coupled inductor and smoothing capacitor combination [5].

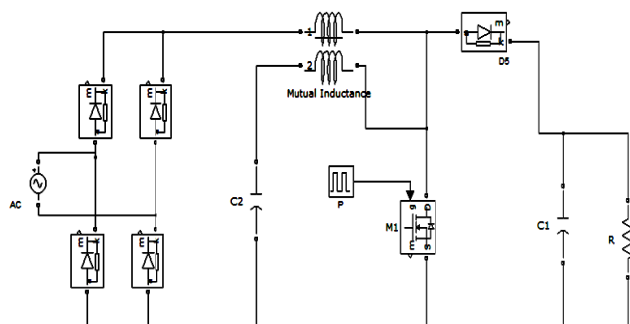

Fig. 2 Modified PFC boost converter with ripple steering technique

Among the different converter topologies, boost topology is also one where ripple- steering technique can be simply applied due to their single-winding inductor and lack of isolation problems. In Fig. 2, the boost converter is modified to achieve zero ripple current [6]-[9]. A second winding has been added to the boost inductor with the driven end in common and a smoothing capacitor C2. In the middle of the smoothing capacitor and the input of the converter a DC path exists, thus the voltage on smoothing capacitor equals supply voltage. This is important in order for the extra winding to distract, the AC component from DC winding. Hence the voltage across them must be same all the time. Experimental results confirms that the suggested PFC boost topology not only produces zero-ripple input current, but also gives power factor closer to unity.

III. DESIGN CONSIDERATION OF IBC

The design of interleaved boost converter [10] involves the selection of the number of phases, the inductors, the output capacitor, the power switch and the output diode. Both the inductor and diode should be identical in all the networks of an interleaved design. The following are the steps involved in the design of IBC.

A. Choice of Duty Ratio

The choice of the duty cycle is based on the number of phases. This is because depending upon the number of phases; the ripple is minimum at a certain duty ratio. For two phase interleaved boost converter, the ripple is minimum at duty ratio, $D = 0.5$. Hence, the design value of the duty ratio is chosen as 0.5. The duty ratio is calculated as

$$D = \frac{V_o - V_{in}}{V_o} \quad (1)$$

where, V_o represents the output voltage (V), V_{in} represents the input voltage (V) and D represents the duty ratio.

B. Choice of Number of Phase

This paper uses two phases since the ripple content reduces with increase in the number of phases. The ripple reduces to minimum when compared to conventional boost converter. If the number of the phases is improved more, without much decrease in the ripple content, the difficulty of the circuit rises very much, thereby increasing the cost. Hence, as a

negotiation between the ripple content, cost and complexity, number of phases is chosen as two. The number of inductors, switches and diodes are same as the number of phases and switching frequency is same for all the phases.

C. Choice of Inductance

The inductance value of AC winding can be calculated as follows:

$$L = \frac{V_{in(min)}^2}{2 * f_s(min) * \frac{p_o}{\eta}} * \left(1 - \frac{\sqrt{2} * V_{in(min)}}{V_{out}}\right) \quad (2)$$

where V_{in} represents the input voltage (V), V_{out} represents the output voltage (V), f_s represents switching frequency (Hz), p_o represents the output power (W) and η represents the efficiency.

Number of AC and DC winding can be found as follows:

$$N_{AC} = \frac{\sqrt{2} * V_{in(min)} * t_{on(max)}}{\Delta B_{ac} * A_e} \quad (3)$$

where V_{in} represents the input voltage (V), t_{on} represents the on time, ΔB_{ac} represents change in flux density (T), and A_e represents the section area of core.

$$K = \frac{N_{AC}}{N_{DC}} \quad (4)$$

where, K represents the coupling coefficient N_{AC} represents the AC turns, N_{DC} represents the DC turns. If the coupling coefficient is assumed as 0.6 then the equation can be written as,

$$N_{DC} = \frac{N_{AC}}{0.6} \quad (5)$$

The relationship between mutual inductance and self-inductance are as follows:

$$M = K \sqrt{L_1 L_2} \quad (6)$$

where, K lies between $0 \leq K \leq 1$, called as coupling coefficient.

D. Choice of Capacitor

The value of capacitance can be calculated using the formula:

$$C = \frac{V_o D T}{R \Delta V_o} \quad (7)$$

where V_o represents the output voltage (V), D represents the duty ratio, R represents resistance (Ω), T represents the switching period and ΔV_o represents the change in the output voltage (V).

E. Choice of Power Devices

The semiconductor device chosen for fabricating the two phase interleaved boost converter is MOSFET IRF840. Proper choice is done in choosing the semiconductor material to improve the performance of the converter.

TABLE I
 SIMULATION PARAMETERS FOR 2-PHASE IBC

Parameters	Values
V_{in}	18V
V_o	30V
R	2Kohm
C	220 μ F
f_s	50KHz
L_m	60mH
D	0.5
α	0.6

IV. SIMULATION RESULTS

Two phase IBC with ripple steering technique is simulated in MATLAB/SIMULINK. Based on the design equations the simulation parameters for the proposed IBC are summarized in Table I.

The supply voltage and current for Uncoupled IBC, Coupled IBC and IBC with ripple steering technique are shown in Figs. 3- 5.

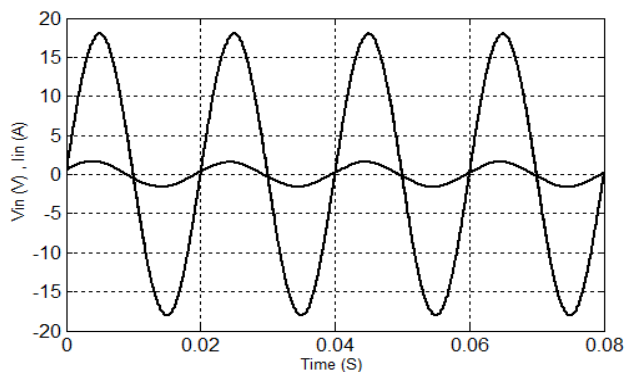

Fig. 3 Supply side Voltage & Current of Uncoupled IBC

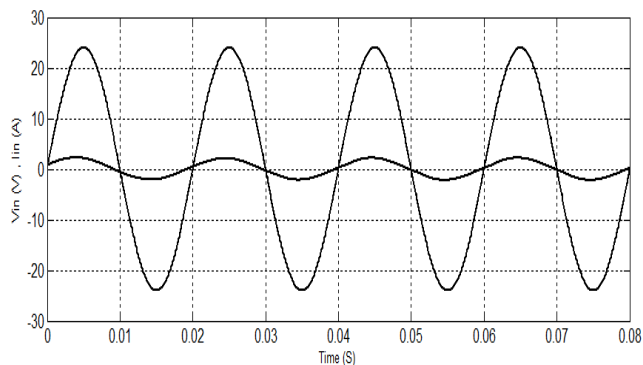

Fig. 4 Supply side Voltage & Current of Coupled IBC

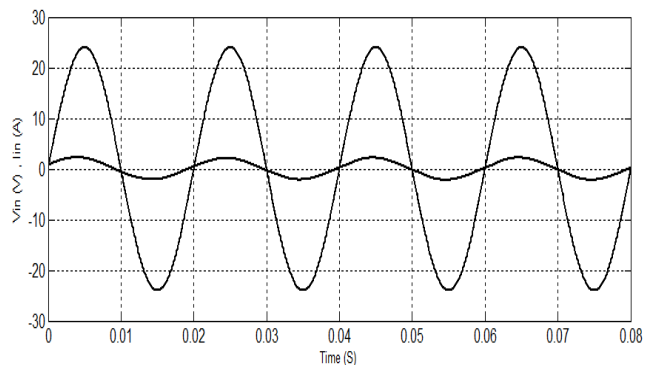

Fig. 5 Supply side Voltage & Current of IBC with Ripple steering

Fig. 5 shows the supply side voltage and current waveforms. The current waveform nearly follows the voltage waveform. Hence the power factor will be closer to one; the current harmonics will be closer to zero.

The output voltage, input current ripple, and output voltage ripple obtained from interleaved boost converter with ripple steering are shown below.

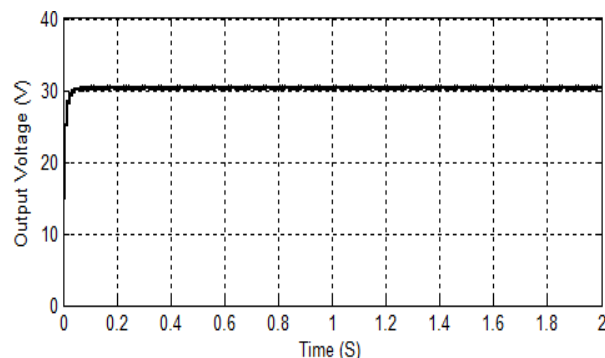

Fig. 6 Output Voltage for the proposed IBC

The above waveform shows the output voltage of the IBC circuit. There is a reasonable increase in the output voltage with respect to the input voltage.

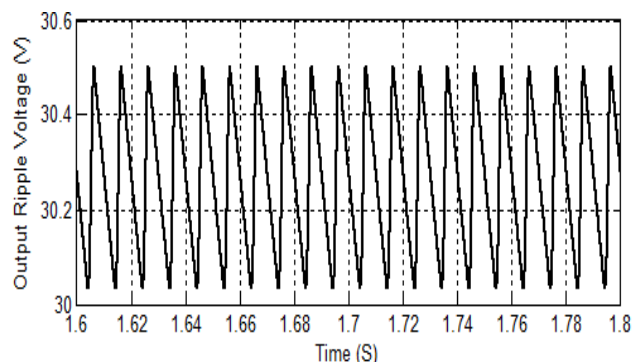

Fig. 7 Output ripple voltage for the proposed IBC

The above waveform shows the output ripple voltage of the proposed IBC circuit.

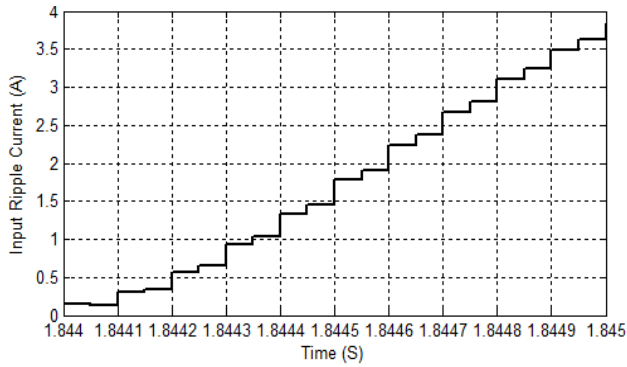

Fig. 8 Input ripple current

The above waveform shows the input ripple current of the IBC circuit. There is a sensible decrease in the ripple.

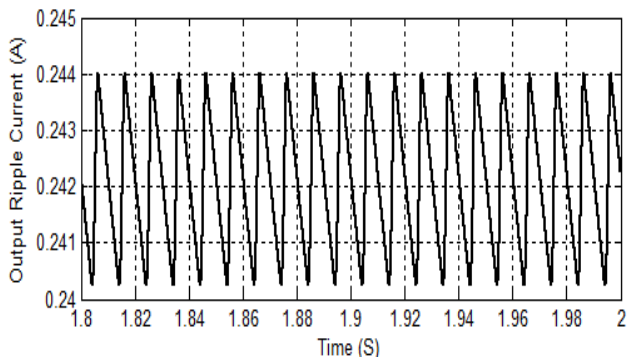

Fig. 9 Output ripple current

The above waveform shows the output ripple current of the IBC circuit.

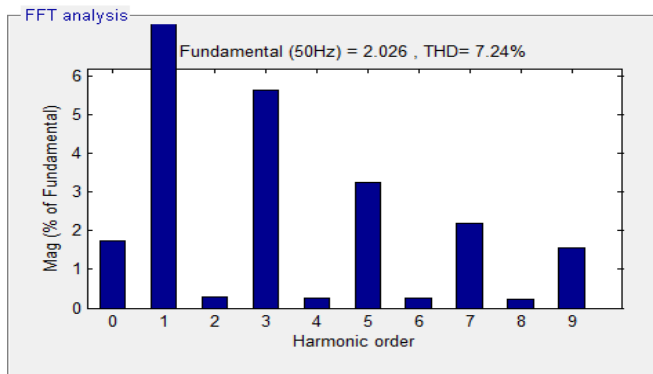

Fig. 10 Supply Current THD

The above figure shows the supply total harmonic distortion of the IBC circuit. And the total harmonic distortion is 7.24% which is very less.

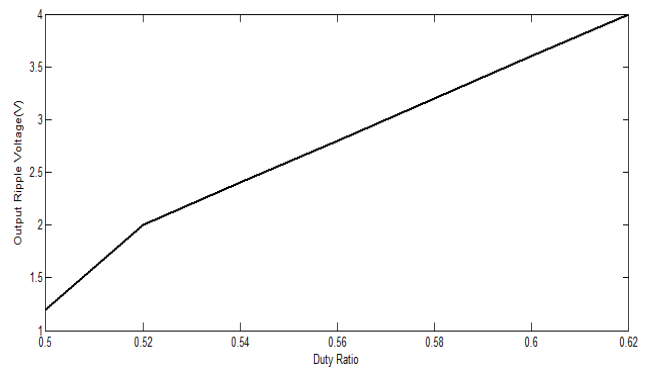

Fig. 11 Output ripple voltage Vs Duty ratio

Fig. 11 shows the graph between output ripple voltage and duty ratio. It is clear that when the duty ratio goes beyond 0.5, the output ripple voltage increases. Therefore the outcomes confirm that, the ripple is less for 0.5 duty ratio.

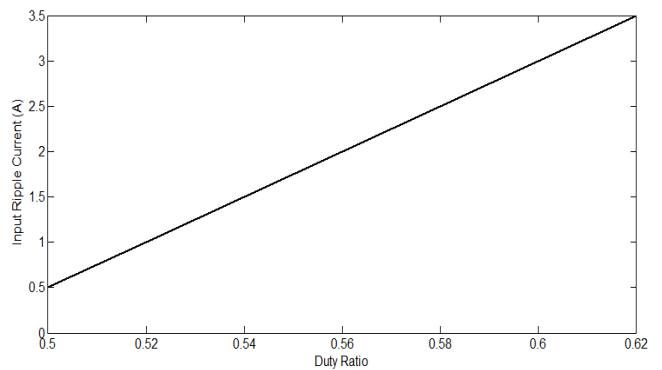

Fig. 12 Input ripple current Vs Duty ratio

Fig. 12 shows a graph between input ripple current and duty ratio. The graph is plotted for various duty ratios from 0.5 to 0.62. At duty ratio 0.5, the input ripple current is very less that is closer to unity. Further increase in duty ratio increases the ripple current.

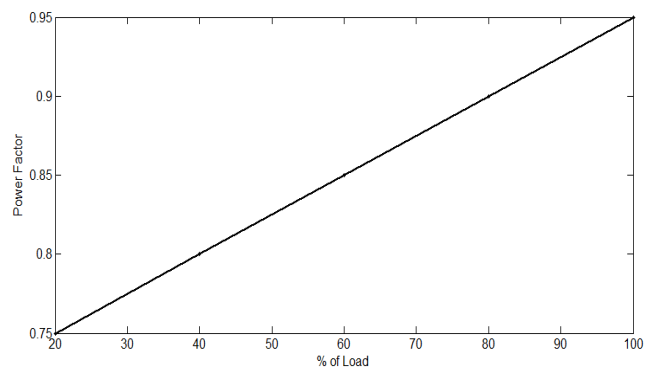

Fig. 13 Power Factor Vs % of Load

Fig. 13 shows the graph between power factor and various percentages of loads. The results show that power factor increases as the load increases. The power factor is closer to unity at full load.

TABLE II
 VARIATION OF RIPPLES FOR DIFFERENT TOPOLOGIES

Parameter	Uncoupled	Coupled	Ripple Steering
Input ripple current	1.33%	1.11%	0.07%
Inductor ripple current	11.6%	14.6%	7.1%
Output ripple voltage	0.07%	0.06%	0.03%

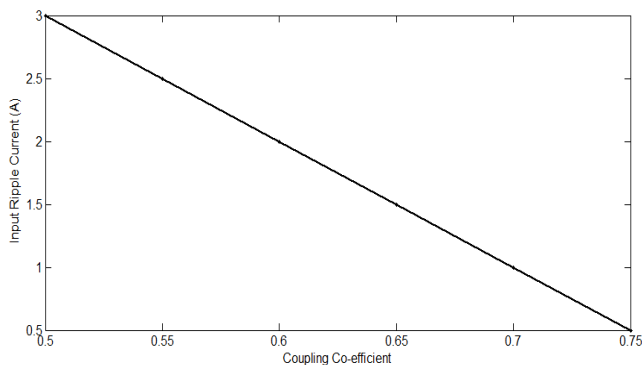

Fig. 14 Input Ripple Current Vs Coupling Co-efficient

Fig. 14 shows a graph between input ripple current and various values of coupling co-efficient. The results show that the ripple current decreases as the coupling co-efficient increases.

A comparison is done between three topologies for the parameters input ripple current, inductor current and output ripple voltage. The outcome shows that, compared to the uncoupled and coupled IBC's, IBC with ripple steering technique gives fewer input ripple which is 0.07%. Also output ripple voltage is 0.03% which is very less compared to other topologies.

Inference:

Between the discussed topologies, interleaved boost converter with ripple steering technique gives fewer ripples compared to other topologies.

IV. EXPERIMENTAL RESULTS

A prototype of a two phase interleaved boost converter with ripple steering has been designed as shown in Fig. 15. In order to validate the simulation results. The hardware arrangement comprises a main power circuit, pulse generation circuit and a power supply circuit for optocoupler. The circuit uses TLP250 optocoupler to isolate the power circuit from the pulse generation circuit. MOSFET IRF840 and the diode BY123 are used to achieve fast switching and high reliability.

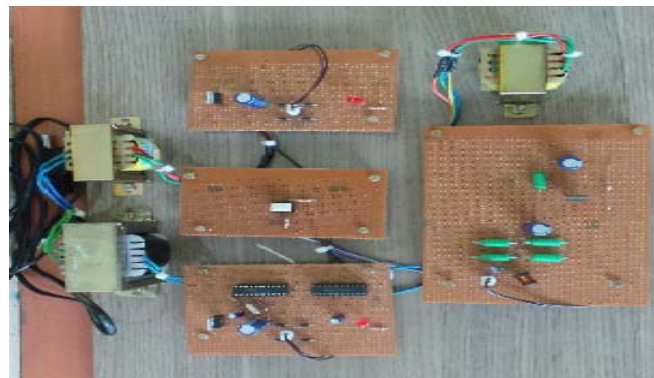

Fig. 15 Experimental prototype of IBC with ripple steering

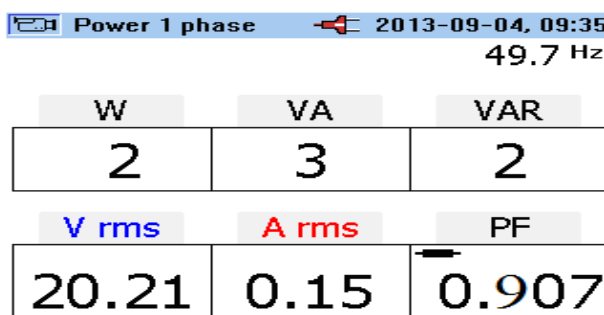

Fig. 16 Supply power factor of IBC with ripple steering

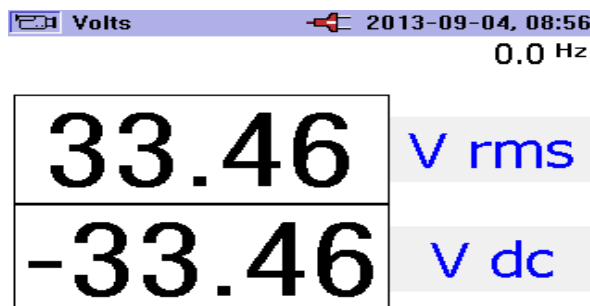

Fig. 17 Output voltage of IBC with ripple steering

The supply power factor and the output voltage of two-phase IBC with ripple steering are shown in Figs. 16 and 17. The result shows the supply power factor is closer to unity.

V. CONCLUSION

Ripple steering technique for boost topology with low input ripple current has been presented in this paper. The proposed topology has a coupled inductor, smoothing capacitor, a switch, and a diode. It is found that the proposed IBC gives reduced ripple current and hence the power factor is closer to unity compared to the traditional boost converter. A prototype of two-phase IBC has been built and the simulation results have been verified experimentally. Thus, from the results, two-phase IBC with ripple steering proves to be encouraging topology.

ACKNOWLEDGMENT

The author is indebted to Dr.R.Seyezhai who has guided generously with valuable suggestions and needed corrections from the experience and expertise.

REFERENCES

- [1] R.Seyezhai, Design Consideration of Interleaved Boost Converter for Fuel Cell system, IJAEST Journal, Vol.7, Issue no: 2, June 2011, pp.323-329.
- [2] Cuk, S., "A New Zero-Ripple Switching DC-to-DC Converter and integrated Magnetic," Proceedings of the IEEE Power Electronics Specialists Conference, Atlanta (GA), Oct. 16-20, pp. 12-32, 1980.
- [3] R. Seyezhai and B.L.Mathur, Design and implementation of fuel cell Based Interleaved Boost Converter, International Conference on Renewable Energy, ICRE 2011 Jan 17-21, 2011, University of Rajasthan, Jaipur.
- [4] Hamill, D.C.Kreien, P.T, "A Zero Ripple Technique Applicable to Any DC Converter," in Power Electronics Specialists Conference, 1999, PESC99. 30th Annual IEEE, Publication Date: 1999 Volume: 2, on page: 1165-1171.
- [5] J. Wang, W. G. Dunford, and K. Mauch, "A Fixed Frequency, Fixed Duty Cycle Boost Converter with Ripple Free Input Inductor Current for Unity Power Factor Operation," in IEEE Power Electronics Specialists Conf., 1996, pp. 1177--1183.
- [6] Milan M. Jovanovic, "Technology Drivers and Trends in Power Supplies for Computer/TELECOM Applications," APEC 2006.
- [7] J. Wang; W.G. Dunford; K. Mauch, "Analysis of a Ripple-Free Inputcurrent Boost Converter with Discontinuous Conduction characteristics" IEEE Transactions on Power Electronics, vol. 12, pp. 684 - 694, 1997.
- [8] E. Chou; F. Chen; C. Adragna; B. Lu, "Ripple steering AC-DC Converters to Minimize Input Filter" in IEEE Energy Conversion Congress and Exposition, ECCE, 2009, pp. 1325 - 1330.
- [9] J.W. Kolar; H. Sree; N. Mohan; F.C. Zach, "Novel Aspects of an Application of 'Zero'-Ripple Techniques to Basic Converter Topologies" in Power Electronics Specialists Conference, PESC. vol. 1, 1997, pp.796 - 803.
- [10] N.K. Poon; J.C.P. Liu; C.K. Tse; M.H. Pong, "Techniques for Inputripple Current Cancellation: Classification and Implementation," IEEE Transactions on Power Electronics, vol. 15, pp. 1144 - 1152 2000.



A. Inba Remy is working as an Assistant Professor, Department of EEE, Loyola-ICAM College of Engineering & Technology, Chennai, India, obtained her B.E. in Electrical & Electronics Engineering from Adhiparasakthi Engineering College in 2004 and her M.E in Power Electronics & Drives from St.Joseph's College of Engineering, Chennai in 2007. She has been working in the teaching field for more than 6 Years. She is currently doing the Ph.D degree at Anna University, Chennai under the guidance of Dr.R.Seyezhai. Her research interests include dc-dc Converter, Converter topologies and renewable energy systems.



Dr. R. Seyezhai is working as an Associate Professor, Department of EEE, SSN College of Engineering, Chennai, India, obtained her B.E. (Electronics & Communication Engineering) from Noorul Islam College of Engineering, Nagercoil in 1996 and her M.E in Power Electronics & Drives from Shanmugha College of Engineering, Thanjavur in 1998 and Ph.D from Anna University, Chennai. She has been working in the teaching field for about 14 years. She has published several papers in International Journals and International Conferences in the area of Power Electronics & Drives. Her areas of interest include SiC Power Devices, Multilevel Inverters, Modeling of fuel cells, Design of Interleaved Boost Converter, Multilport dc-dc Converter and control techniques for dc-dc Converter.