

# Investigation of Electromagnetic Force in 3P5W Busbar System under Peak Short-Circuit Current

Farhana Mohamad Yusop, Syafrudin Masri, Dahaman Ishak, Mohamad Kamarol

**Abstract**—Electromagnetic forces on three-phase five-wire (3P5W) busbar system is investigated under three-phase short-circuits current. The conductor busbar placed in compact galvanized steel enclosure is in the rectangular shape. Transient analysis from Opera-2D is carried out to develop the model of three-phase short-circuits current in the system. The result of the simulation is compared with the calculation result, which is obtained by applying the theories of Biot Savart's law and Laplace equation. Under this analytical approach, the moment of peak short-circuit current is taken into account. The effect upon geometrical arrangement of the conductor and the present of the steel enclosure are considered by the theory of image. The result depict that the electromagnetic force due to the transient short-circuit from simulation is agreed with the calculation.

**Keywords**—Busbar, electromagnetic force, short-circuit current, transient analysis.

## I. INTRODUCTION

COMPUTATION of electromagnetic force to which busbar subjected in short-circuit condition has always been an important issue in order to provide sufficient design of busbar system with most effective safety structure. Thus far, the estimation of electromagnetic force in the busbar system has been extensively carried out by several researchers. Some of them performed a numerical calculation of short-circuit electromagnetic force in a rectangular cross-section of the busbar by applying the steady-state three-phase symmetrical current [1]-[5]. For that case, the peak AC current was assume to be equal to the peak value of the short-circuit current. This calculation method has been further evaluated in IEC Standards of 865/1993 which applied for calculation of electromagnetic force for rectangular rigid bare conductor busbar [6].

However, in the case of three-phase transient short-circuits current, a mathematical approach for determining electromagnetic force is important. Finite element method (FEM) is one of the best solutions for field and force computation which is a widely used in most researches. It has

F. M. Yusop was with School of Electrical and Electronic Engineering, Universiti Sains Malaysia, 14300 Nibong Tebal, P. Pinang, Malaysia (phone: 604-599-6064; fax: 604-594-1023; e-mail: farhana.yusop@yahoo.com).

S. Masri is with School of Electrical and Electronic Engineering, Universiti Sains Malaysia, 14300 Nibong Tebal, P. Pinang, Malaysia (phone: 604-599-6018; fax: 604-594-1023; e-mail: syaf@eng.usm.my).

D. Ishak is with School of Electrical and Electronic Engineering, Universiti Sains Malaysia, 14300 Nibong Tebal, P. Pinang, Malaysia (phone: 604-599-5810; fax: 604-594-1023; e-mail: dahaman@eng.usm.my).

M. Kamarol is with School of Electrical and Electronic Engineering, Universiti Sains Malaysia, 14300 Nibong Tebal, P. Pinang, Malaysia (phone: 604-599-6064; fax: 604-594-1023; e-mail: eekamarol@eng.usm.my).

been used to compute transient electromagnetic force in many types of busbar by taking into account the real shape of the conductors as well as their skin and proximity effect [7]-[10].

In this paper, estimation of short-circuit electromagnetic force is carried out and the result obtained is analyzed and compared with the result of mathematical approaches. 3P5W busbar system which is placed in galvanized steel enclosure has been used in this study. Two-dimensional finite element analysis is implemented in this work by commercial Finite Element (FE) package using Opera-2D. In the first part of this paper, time stepping of finite element method (FEM) by transient analysis is presented for developing the three-phase short-circuits current and electromagnetic force. This transient analysis of simulation method is derived from the Maxwell Stress equation [11]. Peak short-circuit current has been developed in order to estimated the maximum electromagnetic force.

To ensure the effectiveness of this transient analysis in estimating short-circuit electromagnetic force, the result from simulation is compared with the mathematical calculation result. The mathematical calculation is performed for the models with the same short-circuit current implemented during the simulation. The present of inductive material of galvanized steel enclosure as well as the configuration of conductor busbar have been considered along this analysis.

## II. ANALYSIS MODEL OF BUSBAR SYSTEM

Fig. 1 shows the structure of flattened 3P5W busbar system that has been modeled for short-circuit electromagnetic force analysis. The system consists of five equally spaced parallel conductor busbars, such as the earth, neutral, and conductor of phases A, B, and C. These conductors busbar are placed in a compact galvanized steel enclosure. The earthing conductor in the system is electrically connected to the enclosure surface, whereas the other four conductors are separated by distance, a.

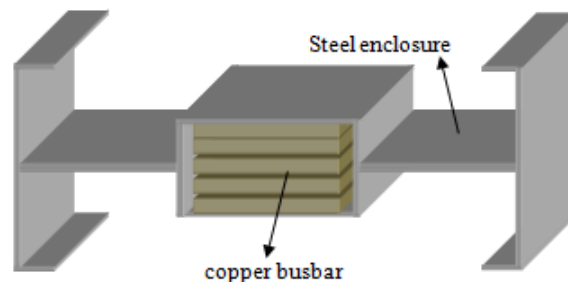

Fig. 1 Model of busbar system

The arrangement of this 3P5W busbar system is shown in Fig. 2. The 2-dimensional busbar is modeled based on the typical design from the manufacturer. Regarding to the no impact of the presence insulating material against electromagnetic force, this insulating has been ignored. However, the spacing between conductors for the busbar model is assumed to be in line with the insulating thickness.

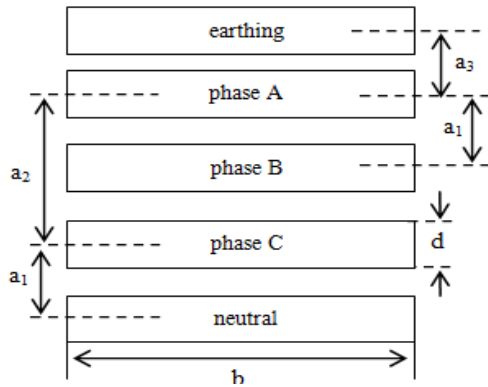

Fig. 2 Dimensional arrangement of conductor busbar

### III. SHORT-CIRCUIT CURRENT ELECTROMAGNETIC FORCE ANALYSIS

#### A. Development of Short-circuit Current

Three-phase short-circuit current is applied to the 3 phase busbar in order to analyze the maximal effect of the electromagnetic force on the mechanical structure of the busbar system [12], [13]. The three-phase short-circuit current can be approximately expressed as follows [14]-[15]:

$$I_a(t) = \frac{V_m}{Z} \sin(\omega t + \alpha - \gamma) - \frac{V_m}{Z} \exp^{-t/\tau} \sin(\alpha - \gamma) \quad (1)$$

$$I_a(t) = \frac{V_m}{Z} \sin(\omega t + \alpha - \gamma - 120^\circ) - \frac{V_m}{Z} \exp^{-t/\tau} \sin(\alpha - \gamma - 120^\circ) \quad (2)$$

$$I_a(t) = \frac{V_m}{Z} \sin(\omega t + \alpha - \gamma + 120^\circ) - \frac{V_m}{Z} \exp^{-t/\tau} \sin(\alpha - \gamma + 120^\circ) \quad (3)$$

where  $Z$  is the total impedance,  $\tau$  is the time constant of the system,  $\alpha$  is the phase angle of the current called switching angle,  $V$  is the maximum voltage, and  $\omega$  is the angular frequency at 50 Hz. The first term of the short-circuit current given in (1), (2), and (3) are the steady-state sinusoidal component, whereas the second term is a DC-transient component known as DC offset which decays exponentially. The  $Z$ ,  $\tau$ ,  $\gamma$  and  $\alpha$  can be expressed as follow,

$$Z = \sqrt{R^2 + X^2} \quad (4)$$

$$\tau = L/R \quad (5)$$

$$\gamma = \tan^{-1}(\omega L/R) \quad (6)$$

$$\alpha = \gamma - \pi/2 \quad (7)$$

In order to generate the short-circuit current of (1)-(3) to the busbar system, an equivalent circuit as shown in Fig. 3 has been implemented. Model of three-phase busbar system is assumed to be connected to a 380 V, 50 Hz AC supply source represented by  $V1$ ,  $V2$ , and  $V3$ . In this circuit, one turn winding  $W1$ ,  $W2$ , and  $W3$  are represented the conductor busbar for each phase. All three windings are short circuit at the end which considering to three-phase short-circuit current. Resistance  $R1$ ,  $R2$  and  $R3$  are connected in series with inductance  $L1$ ,  $L2$  and  $L3$  respectively. This  $R$  and  $L$  for each phase represented the total impedance of the 2-dimensional model busbar system. The value for this parameter has been adjusting in order to generate the peak value of transient short-circuits current in accordance with the RMS short-circuit current value. The impedance also gives some influence on the value of time constant of the system as in (5). The values of  $R$  and  $L$  for this model are shown in Table I.

The three-phase short-circuit current waveform formed from (1)-(3) is shown in Fig. 4. The waveform shows that the peak short-circuits current generated by phase A conductor is 73.5kA within 8 ms. This peak short-circuit is obtained with the value of  $R$  and  $L$  as depicted in Table I.

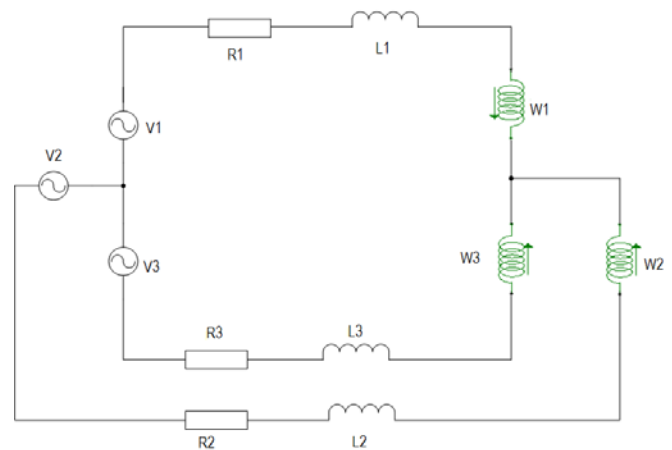

Fig. 3 Equivalent circuit

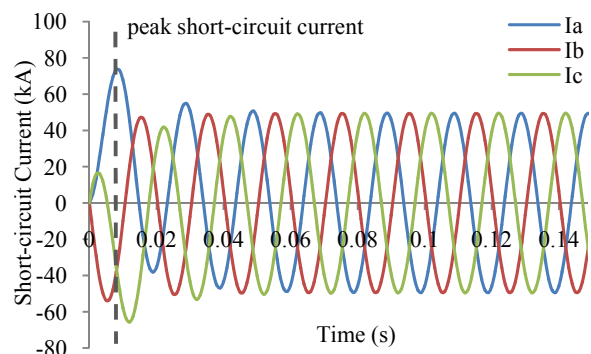

Fig. 4 Three-phase short-circuit current

#### B. Simulation of Electromagnetic Force

The simulation by transient analysis in Opera-2D is applied to ascertain the magnitude of the electromagnetic force of the

copper busbar carrying short-circuit current. In order to analyzed the electromagnetic force, the magnetic properties for the steel and copper are of interest and have been considered during this analysis. The relative permeability,  $\mu_r$  for steel enclosure is declared as 100 while for the copper conductor is 1.

TABLE I  
R AND L VALUES

Model	Peak Current, $i_p$ (kA)	R (m $\Omega$ )	L (mH)
A	63.0	2.1415	0.0264

During the transient analysis in Opera-2D, simulation is conducted up to 0.2 s in order to verify the characteristic of short-circuit electromagnetic force from the moment short-circuit arises until the decay of all transient where the steady-state short-circuit sets in. The simulation is initially performed by estimating the magnetic flux of three busbars produced due to short-circuit current. Figs. 5 (a) and (b) show the distributions of the magnetic flux density in the busbar system at two different time; peak short-circuit current ( $t = 0.008s$ ) and when the current has decay to steady-state condition ( $t = 0.055s$ ).

Fig. 5 (a) shows that the maximum intensity of magnetic flux is distributed in the region between the conductor busbars of phases A and B, which is represented by point X. This result is due to the peak short-circuit current flowing through the conductor busbar of phase A and the current from the neighboring conductors (phases B and C). While Fig. 5 (b) shows that the maximum intensity of magnetic flux is distributed throughout the region B. The intensity of the magnetic flux distribution is almost the same on both sides of the conductor B due to the symmetrical steady-state current carried by the conductor phase A and C as well as peak steady-state current carried by phase B. A higher magnetic flux contributes to the generation of higher electromagnetic force between parallel conductors.

In Opera-2D, the total electromagnetic force per unit length of conductor generated by each conductor busbar is obtained by integrating over the region of each phase of conductor. The electromagnetic force per unit length (N/mm) on a conductor carrying the current density  $J$  in a magnetic flux density  $B$  during short-circuit is described as follow [11].

$$F = \iint J \times B ds \quad (8)$$

The variation of the electromagnetic force per unit length as a function of time is shown in Fig. 6. Due to the symmetrical structure, the direction of the electromagnetic force is considered in the y-direction. In Fig. 6 shows that electromagnetic forces are reduced and are almost identical to one another at  $t = 0.05s$  onwards upon the return of the transient short-circuit current to the steady-state condition. The results reveal that the conductor busbar of phase A experiences the maximum transient electromagnetic force, unlike the other two phases (B and C). The simulation results

of electromagnetic force at this peak short-circuit current has been analyzed and compared with the calculated result.

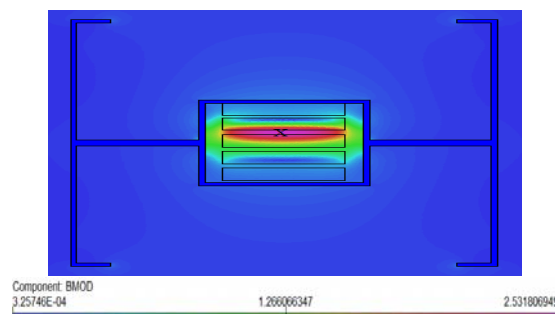

(a) At peak short-circuit current ( $t=0.008$  s)

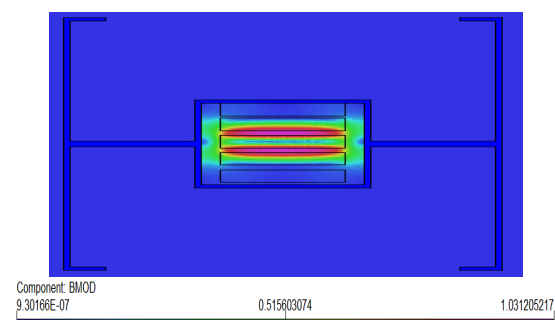

(b) At steady-state short-circuit current ( $t=0.055$  s)

Fig. 5 Distribution of magnetic flux density in busbar system

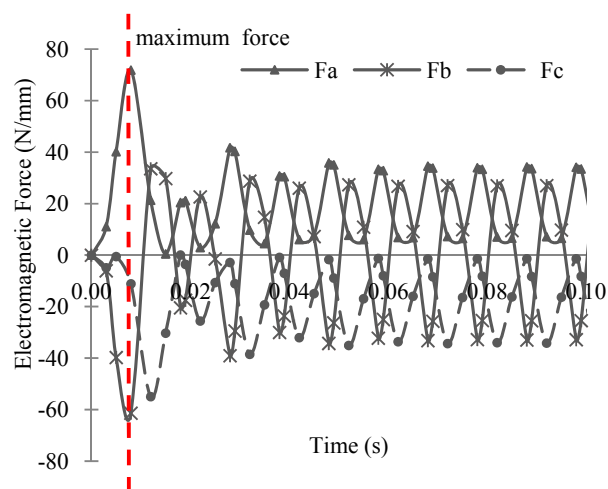

Fig. 6 Characteristic of electromagnetic force under short-circuit current

TABLE II  
DIMENSION OF CONDUCTOR BUSBAR

b	d	a	k
30 mm	6 mm	a1= 8.15 mm	0.52
		a2= 16.3 mm	0.725
		a3= 7.075 mm	0.475

### C. Calculation of Electromagnetic Force

In the magnetic field, an electromagnetic force act on current-carrying conductor is depends on the flux density  $B$ ,

the current intensity  $I$  and the length  $l$  of the current-carrying conductors. This consists of calculating the magnetic flux created by an electric current-carrying conductor, then deducting it for the result of the electromagnetic force exerted. In order to calculate the magnetic flux for a linear conductor, Biot and Savart's Law has been applied [15], [16].

$$B = \frac{\mu_0 I}{2\pi a} \quad (9)$$

The electromagnetic force acting on the conductor busbar caused by short-circuit current and the present of magnetic field is shown as in Fig. 7. The vector map of magnetic field distributed during the simulation as in Fig. 8 is similar with that illustrated in Fig. 7 where the highest magnetic flux is generated between phase A and B conductor acting to the left.

The generated electromagnetic force of a conductor busbar is expressed by Lorentz force as follow [16]

$$\vec{F} = i\vec{dl} \times \vec{B} \quad (10)$$

where,  $F$  represents the electromagnetic force and  $B$  is the magnetic flux density.

For the case of using rectangular conductors instead of conductor of circular section, the electromagnetic force per unit length exerted in air between the conductors is shown by assuming the current to be concentrated upon the centre line. The equation is described as below [15], [17].

$$\frac{\vec{F}}{l} = \frac{\mu_0 I_1 I_2}{2\pi} \left( \frac{k_{ls}}{a} \right) \quad (11)$$

where  $k_{ls}$  is the correction factor that can be determined in most cases on the S-shaped of Dwight's chart [12], [15], [17]. This factor is due to the spacing, thickness and width of rectangular shape conductor. Table II shows the predefined values of  $k_{ls}$  with accordance to the dimensional arrangement of conductor busbar.

However, for this busbar model, the conductors are placed in compact steel enclosure with  $\mu_r = 100$ . These conductors which are close to metal frames may alter the distribution of the magnetic field surrounding them. For this purpose, Theory of Image has been applied and evaluated [16].

The calculation of force upon a long straight conductor close to the inductive material of permeability  $\mu$  can then be made by equation given below

$$F = \frac{4.5I_1 I_2}{10^8 a} \sqrt{l^2 + a^2} - a \quad lb \quad (12)$$

by substitute the  $I_2 = [(\mu-1)/(\mu+1)]I_1$  and assuming the value of  $a$  to be twice the distance separating the conductor and the iron of inductive material. Fig. 9 describes clearly the Theory of Image applied in [16], [17] where the inductive material is replacing by a current carrying conductor similar in every aspect to the original conductor.

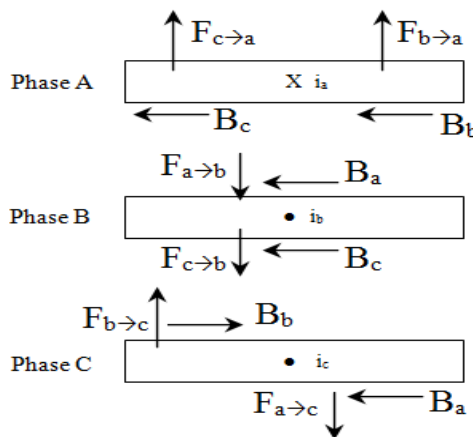

Fig. 7 Direction of short-circuit current  $i$ , magnetic flux density  $B$  and electromagnetic force  $F$ .

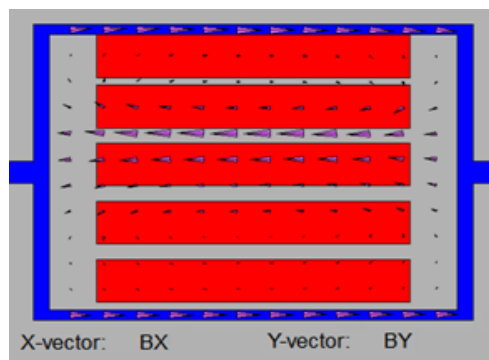

Fig. 8 Vector map of magnetic flux density from Opera-2D

The three-phase busbar system arrangement as shown in Fig. 2 with dimension as stated in Table II are solved using transient analysis. The maximum electromagnetic force obtained due to peak short-circuit current are compared with the calculation result from (11)-(12). The comparison result is shown in Fig. 10. This result leads to the following conclusion which simulation result obtained by FEM of transient analysis is in good correlation with the calculation result.

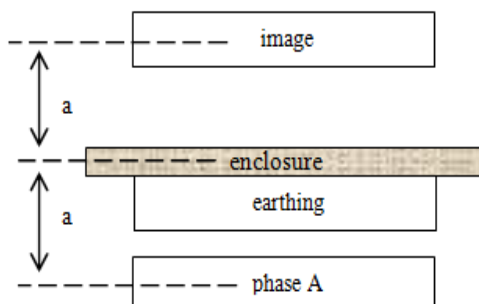

Fig. 9 Description Theory of Image

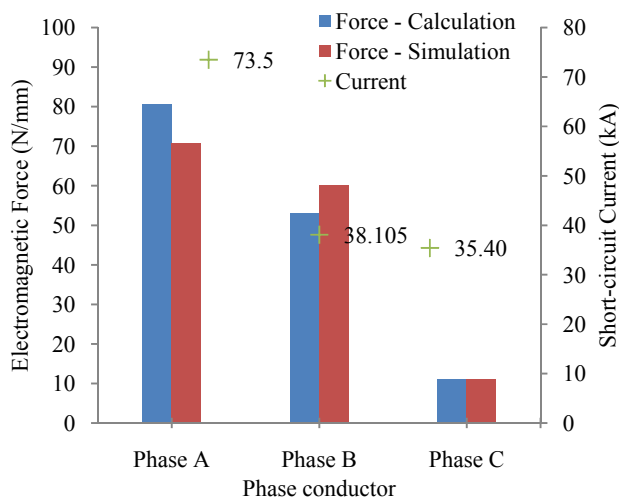

Fig. 10 Electromagnetic force for validation model at peak short-circuit current

#### IV. CONCLUSION

Short-circuit electromagnetic force in three-phase rectangular busbar systems due to short-circuit current has been analyzed. The simulation result of electromagnetic force by transient analysis is in good correlation with the calculation result by considering the dimensional arrangement of the conductor busbar as well as the present of inductive material of enclosure. The effectiveness of this transient analysis in estimating the electromagnetic force also has been proven. The prediction of electromagnetic force is useful and could be a guideline for determining the appropriate structures of the busbar system that can withstand short-circuit current effect.

#### ACKNOWLEDGMENT

The authors are highly indebted to School of Electrical & Electronic Engineering, Universiti Sains Malaysia and Furutek Electrical Sdn. Bhd for their technical and financial support of this project.

#### REFERENCES

- [1] D. P. Labridis and P. S. Dokopoulus, Electromagnetic Forces in Three-Phase Rigid Busbars with Rectangular Cross-Section, IEEE Transactions on Power Delivery, (1996) 793-800.
- [2] B. Shen, X. Zhang, and D. Zhou, Analysis and Calculation of short-Circuit Electromagnetic Forces and Rectangular Bus Bars, IEEE 6th International Power Electronics and Motion Control Conference, Wuhan (2009) 2618 – 2621.
- [3] A. Canova and L. Giaccone, Numerical and Analytical Modeling of Busbar System, IEEE Transaction on Power Delivery, (2009) 1568 – 1577.
- [4] F. M. Yusop, M. K. M. Jamil, D. Ishak, and S. Masri, Electromagnetic Force in Vertical and Horizontal Arrangement of Busbar System under Short-circuit Current, International Review on Modelling and Simulation (IREMOS), (2012) 1645 – 1651.
- [5] F. M. Yusop, M. K. M. Jamil, D. Ishak, and S. Masri, Study on the Electromagnetic Force Affected by Short-Circuit Current in Vertical and Horizontal Arrangement of Busbar System, International Conference on Electrical Control and Computer Engineering, Pahang, Malaysia, (2011) 196 – 200.
- [6] Geneva: IEC, IEC Standard 60865-1: Short-Circuit Current - Calculation of Effects. Part 1: Definition and Calculation Methods, Geneve/Suisse: Bureau Central de la CFI, (1993).

- [7] F. M. Yusop, M. K. M. Jamil, D. Ishak, M. Husaini, and S. Masri, Investigation of Electromagnetic Force during Short-Circuit Test in Three-Phase Busbar System, 2011 IEEE Colloquium on Humanities, Science and Engineering Research, Penang, Malaysia, (2011) 340-344.
- [8] A. H. Isfahani and S. Vaez-Zadeh, Accurate Determination of Electromagnetic Force in Isolated Phase Buses under Short Circuit Conditions, I. P. E. S. G. Meeting, Ed. Tampa, FL, (2007) 1 – 5.
- [9] Arash Hassanpour Isfahani and Sadegh Vaez-Zadeh, Transient Finite-Element Analysis of Short-Circuit Electromagnetic Forces in Isolated Phase Buses, Electromagnetics, (2008) 590-600.
- [10] T. Takeuchi, T. Yoshizawa, Y. Kuse, and H. Hama, 3-D Nonlinear Transient Electromagnetic Analysis of Short Circuit Electromagnetic Forces in a Three-Phase Enclosure-Type Gas Insulated Bus, IEEE Transaction on Magnetics, (2000) 1754 - 1757.
- [11] V. F. S. S. Cobham Antenna Systems, Opera-2D Reference Manual Version 14.0, Cobham Technical Service, (2010).
- [12] I. Kasikci, Short circuits in power systems, Wiley-VCH Verlag-GmbH, 2002.
- [13] J. Schlabbach, Short-circuit Currents, The Institution of Electrical Engineers, 2005.
- [14] Hadi Saadat. Power system analysis, McGraw-Hill, 2002.
- [15] J. P. Thierry and C. Killindjian, Electrodynamic Forces on Busbars in LV Systems, Cahier Technique Merlin Gerin (1996).
- [16] G. L. E. Metz, Electromagnetic force set up between current-carrying conductors during short-circuit, (1993) 527 – 541.
- [17] Dwight, H. B, Calculation of Magnetic Force on Disconnecting Switches, Transactions of the American I.E.E., (1920) 1337

**Farhana Mohamad Yusop** was born in 1987. She has obtained her B. Eng. (Hons) and MSc degree in electrical engineering from Universiti Sains Malaysia (USM) in 2010 and 2013, respectively



**Syafrudin Masri** was born in Pontianak, Indonesia, in 1959. He received his B. Sc (Hons) degree in Electrical, M.Sc in Electric Energy Conversion, and PhD in Electrical Power from Institut Teknologi Bandung in 1987, 1992 and 2000, respectively. His experiences in the field includes as Consultant for Mitsui. Co from 1993-1997. He was a lecturer at Tanjungpura Universiti, Indonesia in 2000. Dr Syafrudin Masri is currently working as Associate Professor in School of Electrical and Electronic Engineering, USM. His Research interest includes Power Quality, Power Electronics Application, Green and Renewable Technology.



**Dahaman Ishak** was born in 1967. He obtained his B.Sc. degree in Electrical Engineering from Syracuse University, New York in 1990. After having worked for several years as Electrical Engineer with Goodyear Malaysia Bhd., he continued postgraduate study and obtained Msc degree in Electrical Power from University of Newcastle Upon Tyne, United Kingdom in 2001. Later in 2005, he received PhD degree from Sheffield University, United Kingdom. He is now working as a senior lecturer in School of Electrical and Electronic Engineering, USM. His main research interests are high performance permanent magnet brushless machines, electrical drives, power electronics, renewable energy, electric vehicles, and hybrid electric vehicles. He has published more than forty articles in reputable journals and international conferences. Dr Dahaman is a registered professional engineer with Board of Engineering Malaysia (BEM) and also a member of IEEE.



**Mohamad Kamarol Mohd Jamil** was born in 1971. He received B.Eng. (Hons) degree from Universiti Teknologi Mara (UiTM), Malaysia in year 2000. Then, he received M. Eng. and D. Eng. degrees in Electrical Engineering from Kyushu Institute of Technology, Japan in 2005 and 2008, respectively. He is now working as a senior lecturer at School of Electrical and Electronic Engineering, USM, Malaysia. His main research interest are investigation on high voltage insulation properties of vacuum, gas, liquid and solid dielectric, partial discharge detection technique, renewal energy and electrical busbar study. Dr Mohamad Kamarol is a member of IEEE, IEM and BEM. He has received Chatterton Young Investigation Award in 2006 from International Symposia on Discharge and Electrical Insulation in Vacuum (ISDEIV).