

A Semi-Cylindrical Capacitive Sensor Used for Soil Moisture Measurement

Subir Das, Tuhin Subhra Sarkar, Badal Chakraborty

Abstract—Differing from the structure of traditional parallel plate capacitive sensor a semi cylindrical capacitive sensor has been introduced in this present work to measure the soil moisture conveniently. Here, the numerical analysis method to evaluate the capacitance from the semi-cylindrical capacitive sensor is analyzed and discussed. The changes of capacitance with the variation of soil moisture obtained linear in the nano farad range (nF) and which converted into voltage variation by using proper signal conditioning circuit. Experimental results depict the satisfactory performance of the sensor for measurement of soil moisture in the range of 0 to 70%. We investigated the linearity of 4% of FSO and sensitivity of 70 mV/unit percentage changes in soil moisture level (DB).

Keywords—Semi cylindrical Capacitive Sensor, Capacitance to Voltage converter Circuit, Soil Moisture.

I. INTRODUCTION

STUDY of soil for agricultural purpose is one of the main focuses to the researcher since the beginning of civilization, because food requirement is throughout linked with the soil. The development of new techniques in the measurement of moisture, agriculture is benefitting in a great way. From scientific perspective, the use of instrumentation for soil water determination can satisfy an academic interest in the dynamics of the flow of water and solutes [1]. From a practical engineering perspective, instrumentation of soil moisture measurement can provide guidance for agricultural perspective, helping to assure short term economic yield and long term environmental protection [1]. The study of soil has generated an interest among the researchers for very similar other reason like understanding of soil water dynamics, transmission, reflection and refraction of signals with the help of sensors network for monitoring the soil characteristics.

There are several techniques employed to monitor soil's moistures which include gravimetric techniques, neutron scattering [2]-[3], resistive methods [4], acoustic sensors [5]. For measuring soil moisture the oven drying technique is most widely used among the all gravimetric techniques. Actually, this technique derives removing a soil sample from the field and determining the mass of water content in relation to mass of dry soil.

Subir Das and Tuhin Subhra Sarkar are with the Electronics & Instrumentation Engineering Department, Murshidabad College Of Engineering and Technology, Berhampore, Murshidabad, West Bengal, India (phone: +91-9475258979; e-mail:sarkar.tuhin@murshidabadcollege.ac.in, subir.mcet@gmail.com).

Badal Chakraborty is with the Faculty of Agriculture Engineering, Bidhan Chandra Krishi Viswavidyalaya, Mohanpur, Nadia, West Bengal, India (e-mail: baduchak@yahoo.co.in).

But this technique has some disadvantages which includes drying time, sampling time etc. Neutron scattering method involves measuring estimating volumetric water content from the sample soil. Advantage of this method is measuring a large amount of soil and amount of water involved into the soil. But disadvantage is that instruments using by the procedure are cost effective. This method has some radiation hazards and also insensitivity arise near the soil surface. Hence, to overcome the limitations of material properties and simplify the complexity of measuring systems to decrease cost for the industry, Khan et al. [4] designed a high accuracy measurement circuit based on resistive methods, employing a bridge amplifier, an integrator, and a comparator, for detecting the moisture content of soil. This circuit has the advantage of detecting soil resistance with better accuracy and with wide-range of linearity. An innovative soil moisture measuring unit using thermal conductivity properties of soil has been introduced by Das et al. [6] which depict good linearity and accuracy in a low cost range. Another low economic sensing techniques employed by the researchers is capacitive type moisture sensors. Majid et al. [7] design soil moisture capacitive sensor interface circuit based on phase differential technique, according to them the circuit has been designed and fabricated using MIMOS' 0.35 μ m CMOS technology. Simulation and test results show linear characteristic from 36 – 52 degree phase difference, representing 0 – 100% in soil moisture level. Test result shows the circuit has sensitivity of 0.79mV/0.10 phase difference, translating into resolution of 10% soil moisture level. A Wireless soil moisture sensor based on Fringing Capacitance has been designed by Wobschall et al. [8] which based on the mixtures of dielectric particles which are conducting. Dielectric constant is dependent on moisture content by volume. Beyond on this application capacitive sensors have been used in various sensing applications, such as force, pressure, acceleration, dielectric properties and displacement sensors [9], [10]. In addition, capacitive sensors are not only employed to monitor soil's moisture but also used to estimate amount of rainfall [11], proximity sensor [12] and even as a biomedical sensor [13]. These entire capacitive sensor structures either parallel plate or cylindrical shaped. Until now, no study has been discussed on semi cylindrical shaped capacitive sensors to sense these physical parameters. But this type of sensor was successfully installed and exhibits good characteristics for the measurement of liquid flow rate [14], liquid level measurement system [15] etc. Hence, differing from the structures of cylindrical capacitive sensors, we have

investigated a semi cylindrical capacitive sensor for soil moisture measurement.

In this paper, a semi cylindrical capacitive sensor with a signal conditioning circuit has been designed and tested for soil moisture measurement also a numerical analysis method to evaluate the capacitance from the semi-cylindrical capacitive sensor is analyzed and discussed. We proved that the sensing method of the semi cylindrical capacitive sensor for soil moisture measurement has been worked successfully and the experimental results shows good linearity and sensitivity in the nano farad (nF) range of capacitance variation due to moisture content in the soil. The introduction is followed by a representation of the working principle, constructional details, the experimental investigation, and a series of discussion topics based on the experiment.

II. FABRICATION OF THE SEMI-CYLINDRICAL CAPACITIVE SENSOR

The semi-cylindrical capacitive sensors has been designed and constructed from two aluminum plates of thickness 0.2mm, length 50mm, and width 30mm. Each plate has been bent to form a semi cylindrical plates are mounted vertically in the outer wall of the PVC container using adhesive as shown in Fig. 1. Two semi cylindrical plates are separated by a gap distance of 5mm. The inner diameter of PVC container is 15 mm and thickness is 3mm.

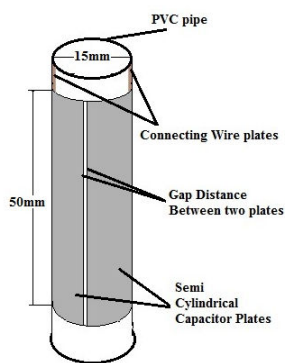

Fig. 1 Isometric view of semi cylindrical capacitive moisture sensor

III. MEASUREMENT OF CAPACITANCE FOR SEMI CYLINDRICAL CAPACITIVE SENSOR

The semi-cylindrical capacitive sensor consists of two metal semi-cylindrical plates, which are separated by a gap distance d . Fig. 2 shows the structure of the semi cylindrical capacitive sensor without dielectric materials.

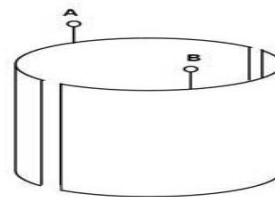

Fig. 2 The structure of the semi-cylindrical capacitive sensor without dielectric material

In Fig. 2 the dielectric material is air, thus the dielectric constant ϵ_1 is equal to 1. Fig. 3 (a) displays the top view of the semi-cylindrical capacitive sensor without dielectric material. The two metal semi-cylindrical plates have the radius R and minimum gap distance between is d .

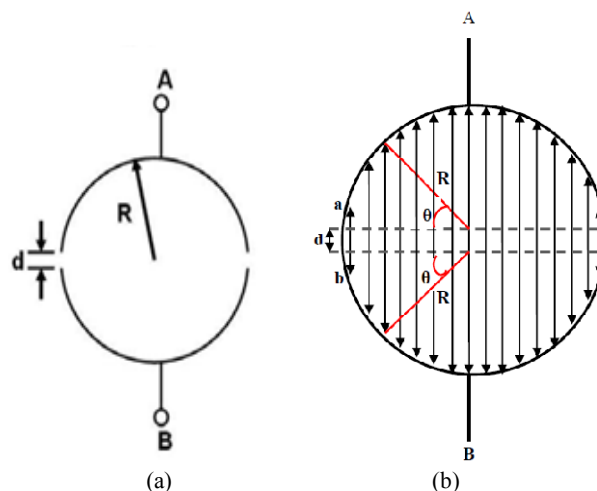

Fig. 3 (a) The top view of the semi-cylindrical capacitive sensor without dielectric material; (b) The electric field distribution inside the semi-cylindrical capacitive sensor without dielectric material and symbolic representation for numerical analysis method

The numerical analysis method is applied to approximate the capacitance of the semi-cylindrical capacitive sensor. Fig. 3 (b) shows the electric field distribution inside the semi-cylindrical capacitive sensor for numerical analysis method. The basic difference between the parallel plate capacitor and semi cylindrical capacitor is that the gap distance at any point of these two plates are varies along the curved surfaces. To estimate this capacitance Assume that 'A' plate is +Q charged and 'B' plate is -Q charged. Potential difference between two plates is V . So, the electric field between the plates is $E = Q/A\epsilon_0$. Due to semi cylindrical structure of the plates the area of it is πRH . Therefore,

$$E = \frac{Q}{A\epsilon_0} = \frac{Q}{\pi RH\epsilon_0} \quad (1)$$

Now potential difference (V) can be expressed as

$$V = \int_b^a \vec{E} \cdot d\vec{l} + \int_0^\pi \vec{E} \cdot d\vec{l} \quad (2)$$

The edges of two plates which have fixed separation with the gap distance of 'd' and it varies along with the curved surfaces. Now the gap distance in between of any points of the curved surface from the edges is $L = 2R\sin\theta$ where θ is the angel between the radius (R) and the horizontal plane of the curved surface. So, the rate of change of gap distance in between of two curved surface with respect to the angel θ is

$$dL = 2R\cos\theta d\theta \quad (3)$$

Hence the actual gap distance between of two plates is

$$dl = 2R\cos\theta d\theta + d \quad (4)$$

Due to semi circular shape of plate's θ are lies in between of 0 to π . combining (1) and (3) and we can get (2) as

$$V = \frac{Qd}{\pi RH\epsilon_0} + \int_0^\pi \frac{Q2R\cos\theta d\theta}{\pi RH\epsilon_0} \quad (5)$$

$$= \left[\frac{Qd}{\pi RH\epsilon_0} + \frac{Q2R\sin\theta}{\pi RH\epsilon_0} \right] \quad (6)$$

$$= \frac{Q}{\pi RH\epsilon_0} [2R\sin\theta + d] \text{ where, } 0 \leq \theta \leq \pi \quad (7)$$

Now the capacitance

$$C = Q/V$$

$$= \frac{Q}{Q/\pi RH\epsilon_0 [2R\sin\theta + d]} \quad (8)$$

$$= \frac{\pi RH\epsilon_0}{2R\sin\theta + d} \text{ where, } 0 \leq \theta \leq \pi \quad (9)$$

In our designed semi-cylindrical structure, two metal plates are fixed over the outside wall of PVC pipe by a self adhesive, so the dielectric medium between the plates is air, PVC pipe coating and soil sample. So, the actual capacitance, neglecting the PVC pipe thickness, will be

$$C = \frac{\pi RH\epsilon_0\epsilon_1\epsilon_2\epsilon_3}{2R\sin\theta + d} \quad (10)$$

where, ϵ_3 is the dielectric constant for soil sample. If we assume that the thickness of PVC pipe is t then radius (R) of semi circular plates from the centre of PVC pipe, is simplified as

$$R = r + t \quad (11)$$

where, r is the inner radius of the PVC pipe. Eventually we got an expression utilizing (11) for semi cylindrical capacitive sensor is

$$C = \frac{\pi(r+t)H\epsilon_0\epsilon_1\epsilon_2\epsilon_3}{2(r+t)\sin\theta + d} \quad (12)$$

From (12) it is obvious that if the dielectric constant (ϵ_3) due to soil sample has been changed, the effective capacitance will also change when all other parameters are remain constant. Thus soil moisture measurement in terms of capacitance of the semi cylindrical plates can be possible.

IV. WORKING PRINCIPLE AND SIGNAL CONDITIONING CIRCUIT

To measure the soil moisture according to the variation in capacitance of the semi cylindrical capacitive sensor, the designed capacitive probe has been filled up by the sample (soil) that makes a change in dielectric medium (ϵ_3) inside the capacitors plate. The dielectric constant ϵ_3 is depends on the soil characteristic and moisture content presents in it. In our experimental process for a specific soil sample, characteristic property is constant and moisture content varies with different level by changing its water level in a fixed volume of sample so, the dielectric constant ϵ_3 is purely depends on the moisture level. As the dielectric constant varies with different values of moisture level the measured capacitance in this proposed sensor varied accordingly. To calibrate this variation of capacitance with the moisture level a signal conditioning circuit has been used. The basic block diagram of this measurement system is shown in Fig. 4.

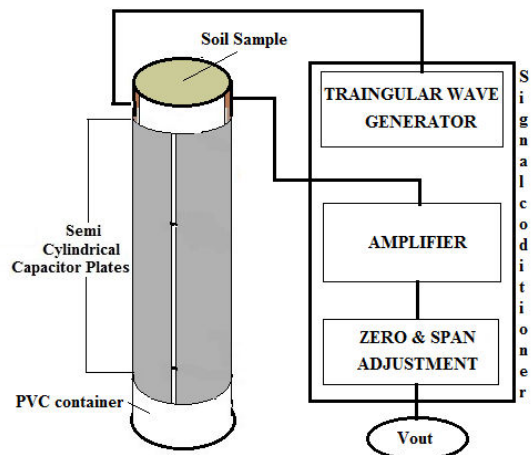

Fig. 4 Block Diagram of soil moisture measurement system using semi cylindrical capacitive sensor

In this proposed measuring system, capacitance has been converted into voltage by a signal amplitude variation method. In this method, our designed semi cylindrical capacitor (C_1) plays a vital role to change the input signal in a different shape with varying amplitude; this phenomenon has been established by a simple Differentiator circuit. An input signal (Type: triangular wave, Frequency: 1KHz, Amplitude: 5V) has been fed to a differentiating circuit through a measured capacitor as shown in Fig. 5 and turn out an output signal in a Square wave form with same input frequency but dissimilar amplitude. When the semi cylindrical capacitive sensor probe (C_1) has been filled up by the sample (soil) from which moisture level has to be measured, the triangular wave shape signal differentiated by the circuit element R_1 and C_1 and produces a square wave output. The amplitude of the output signal is

dependent on the differentiating gain factor R_1 and C_1 . Where the value of R_1 is constant and the value of C_1 varies according to the moisture content of the soil. Eventually, to sense the amplitude of the output signal a half wave precision rectifier with filter circuit has been used and following this expected output voltage a zero-span adjustment circuit has been applied for proper calibration and acquisition of the sample moisture level in a recordable voltage form. The experiment has been performed repeatedly and obtained satisfactory results in each time.

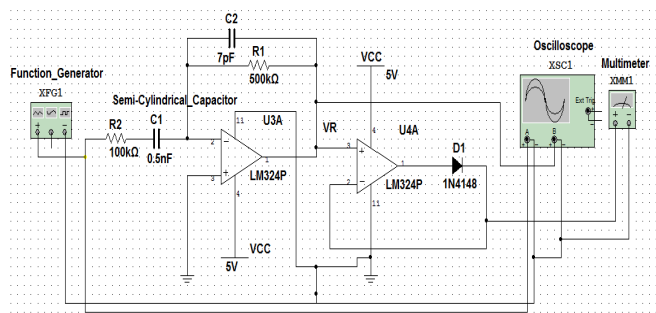

Fig. 5 Simulated circuit diagram without Filter & Zero-Span adjust circuit

V. EXPERIMENTAL SETUP & RESULT

During the experimental process we have used a Function generator to provide an input signal with specified parameters and select the value of feedback resistance (R_1) depending upon the range of measured capacitance (C_1) due to which the value of gain factor (R_1C_1) is equal to or larger than the time period of input signal; it is required to differentiate the input signal properly. Utilizing the standard LCR meter it is found that the maximum value of C_1 is 0.5nF when the soil moisture level reaches to 70% and minimum value (0.01nF) due to completely dry soil; this soil sample was measured by standard soil moisture meter. Finally MATLAB software is performed to calculate theoretically the capacitance between two semi cylindrical plates using (12) and calculated value of capacitance match the experimental value successfully. These entire ranges of capacitance has been plotted graphically against the soil moisture level and found a linear variation with them, as shown in Fig. 6.

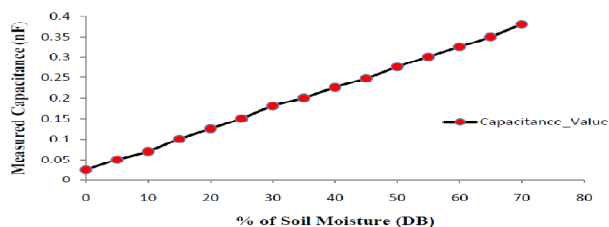

Fig. 6 Variation of capacitance due to the changes of soil moisture

The value of feedback resistance (R_1) is 500K Ω and the maximum value of capacitance (C_1) is 0.5nF hence according to the proper definition of signal differentiation the time

period (T) of input signal should be equal to or larger then 0.25ms, i.e. approximately frequency of 4 KHz. So in this connection we have chosen an input signal frequency of 1 KHz, i.e. time period of 1ms which has greater value of 0.25ms. In Fig. 5, The peak output voltage of differentiator is V_R and can be expressed as

$$V_R = \frac{R_1 C_1 V_p}{t} \quad (13)$$

From (13) it is obvious that due to changes in capacitance (C_1) the peak output voltage (V_R) has been varied linearly and the evidence of experimental result are shown in Figs. 7-9 respectively.

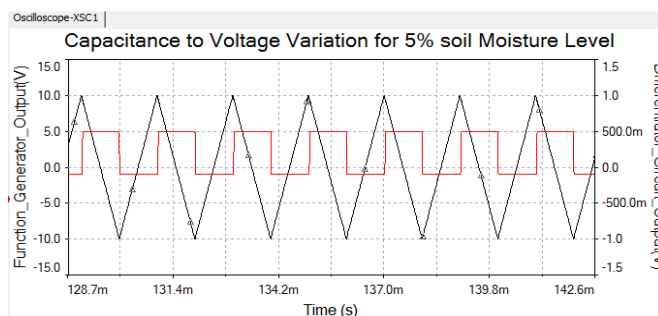

Fig. 7 Signal amplitude variation due to 5% of soil moisture level

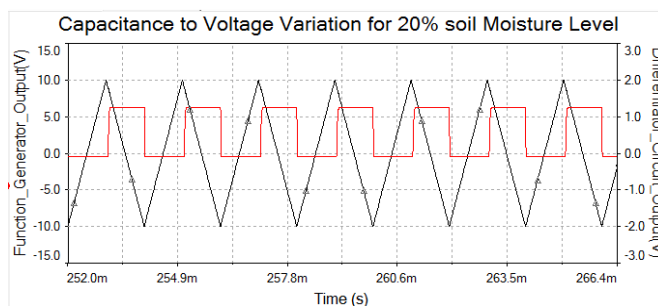

Fig. 8 Signal amplitude variation due to 20% of soil moisture level

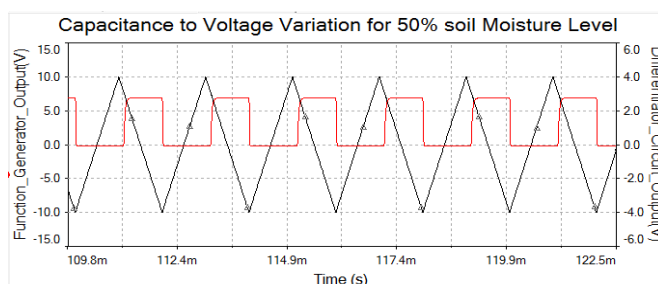

Fig. 9 Signal amplitude variation due to 50% of soil moisture level

Due to linear changes in voltage (V_R), the output of precession half wave rectifier will be varies linearly with the soil moisture level and eventually it has been calibrated with the voltage range of 0 to +5V for the moisture level range of 0-70% as shown in Fig. 10.

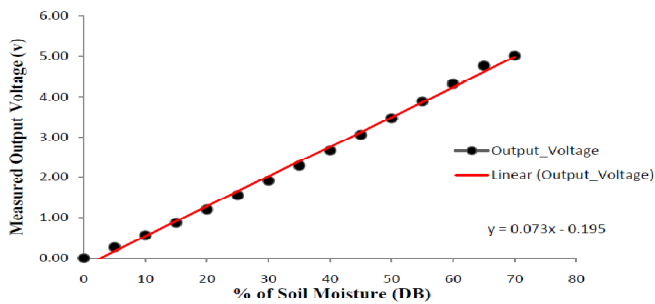

Fig. 10 Calibrated output voltage variation with respect to different soil moisture level

From Fig. 10, it is obvious that the output voltage (V_{out}) of signal conditioning circuit has approximately linear with the measured soil moisture range (0-70%). Hence we have calculated the non linearity of that curve utilizing best-fit straight line method and find the value of 4% FSO (Full Scale Output) at the soil moisture level of 65%. The obtained measurement sensitivities in linear regions is 70 mV/ unit changes in soil moisture level (DB) for 0 to 70% range. The accuracy of this measurement is 0.69 DB, which is defined as the maximum difference between the applied angle values and calculated values from the experimental data.

IV. CONCLUSION

The designed sensor is efficient, in expensive and multipurpose. It could be integrated with the other primary non electrical sensors and order to get an electrical read out. The advantage of the presented realization compared to the other scientific paper [7]-[8] is it has exhibits extended linearity in the range of 0 to 70% in soil moisture level with an accuracy of 0.69 DB and sensitivity of 70mV/unit change in soil moisture level which has realized better sensor characteristics in compared to 0.79mV/10% of soil moisture level [7] at very simple constructional schemes.

This sensor module can be used beyond of this measured range and also it could be used as a remote monitoring system and computer aided simulation system by interface with a DAS card; it is the future scope of work.

REFERENCES

- [1] Dr. Clinton, C. Shock, "Instrumentation for Soil Moisture Determination", Professor and Superintendent Malheur Experiment Station Oregon State University, June 18, 1998.
- [2] Helen Geirinhas Ramos, Mario Trindade and A. Cruz Serra, "A Measurement System to Automate Laboratory Testing In Soils" Centro de Electrotecnia Teorica e Medidas Electricas DEEC -I.S.I., Technical University of Lisbon 1096 Lisboa Cordex Portugal, *IEEE Instrumentation and Measurement Technology Conference*, Ottawa, May 19-21, 1997.
- [3] Yang Du, Fawwaz T. Ulaby and M. Craig Dobson, "Sensitivity to Soil Moisture by Active and Passive Microwave Sensors", *IEEE transactions on geosciences and remote sensing*, vol. 38, no. 1, 2000.
- [4] Khan, Sheraz, Alam, A. H. M. Zahirul, Khalifa, Othman O., Islam, Mohd Rafiqul, Zainudin, Zuraidah, Khan, Muzna S., and Pauzi, Nurul Iman Muhamad, "A High Accuracy Measurement Circuit for Soil Moistur Detection", *International Journal of Mathematical, Physical and Engineering Sciences*, vol.02, no. 02, pp. 59-62, 2008.
- [5] Francesco Adamo, Gregorio Andria, Filippo Attivissimo, and Nicola Giaquinto, "An Acoustic Method for Soil Moisture Measurement",

- IEEE Transactions on Instrumentation and Measurement*, vol. 53, no. 4, 2004.
- [6] S. Das, B. Bag, T. S. Sarkar, N. Ahmed, B. Chakraborty "Design and Fabrication of a Soil Moisture Meter Using Thermal Conductivity Properties of Soil", *Sensor & Transducer Journal*, Vol. 132, No. 9, pp. 100-107, 2011.
- [7] Majid, H. A., N. Razali, Sulaiman, M. S., and A'ain A. K., "A Capacitive Sensor Interface Circuit Based on Phase Differential Method" *World Academy of Science, Engineering and Technology*, Vol.31, pp. 636-639, 2009.
- [8] Wobschall D, "A Theory of the Complex Dielectric Permittivity of Soil Containing Water: The Semi-Disperse Model," *IEEE Geo. Trans.* Vol. 15, pp.49-58, 1977
- [9] T. N. Toth and G. C. M. Meijer, "A Low-Cost Smart Capacitive Position Sensor," *IEEE Trans. Instrum. Meas.*, vol. 41, no. 6, pp. 1041-1044, 1992.
- [10] L. K. Baxter, *Capacitive Sensors Design and Applications*. New York: IEEE Press, 1997.
- [11] I. Bord. P. Tardy, and F. Menil, "Influence of the Electrodes Configuration on a Differential Capacitive Rain Sensor Performances" *Sensor & Actuators B*, vol.114, no.2, pp 640-645, 2006.
- [12] Z. Chen and R. C. Luo "Design and Implementation of Capacitive Proximity Sensor Using Microelectromechanical System Technology", *IEEE Trans. Ind. Electron.* vol.45, no.6, pp.886-894, 1998.
- [13] F. Dewarrat, L. Falco, A. Caduff, M. S. Talary, Y. Feldman and A. Puzenko, "Measurement and Simulation of Conductive Dielectric Two Layer Materials with a Multiple Electrodes Sensor" *IEEE Trans Dielectric Elect. Insul.* vol.15, no.5, pp.1406-1414, 2008.
- [14] Cheng-Ta Chiang, Yu-Chung Huang, "A Semi-Cylindrical Capacitive Sensor With Interface Circuit Used for Flow Rate Measurement", *IEEE Sensors Journal*, Vol. 6, No. 6, pp. 1564-1570, 2006.
- [15] Sagarika Pal, Rasmiprava Barik "Design, Development and Testing of a Semi Cylindrical Capacitive Sensor for Liquid Level Measurement", *Sensors and Transducers Journal*, Vol.116, No.5, pp.13-20, 2010.

Subir Das was born in West Bengal, India in 1984. He received Bachelor's degree in electronics & instrumentation engineering from West Bengal University of Technology, West Bengal, India in 2006 and M.Tech degree in instrumentation & control engineering from University of Calcutta, West Bengal, India in 2010.

He is currently an Assistant Professor in Applied Electronics & Instrumentation Engineering at Murshidabad College of Engineering & Technology, Berhampore, West Bengal, India. He worked with Danieli Automation, West Bengal, India, Core-Technologies, West Bengal, India and Stesalit India Ltd. West Bengal, India between 2006 and 2008. His research interests include the design of sensors and transducers, robotics automation, industrial automation and image processing. He has authored or coauthored more than 8 research papers in the areas of the sensors and transducers, and design of electronics measuring systems.

Tuhin Subhra Sarkar was born in West Bengal India in 1981. He received Bachelor's degree in electronics & instrumentation engineering from University of Kalyani, West Bengal, India in 2004 and M.Tech degree in computer science and engineering from University of Kalyani, West Bengal, India in 2006.

He is currently an Assistant Professor in Applied Electronics & Instrumentation Engineering at Murshidabad College of Engineering & Technology, Berhampore, West Bengal, India. He has been a visiting Lecturer in Sheikhpura A. R. M. Polytechnic, West Bengal, India between 2006 and 2007. His research interests include the design of sensors and transducers, VLSI, network security and image processing. He has authored or coauthored nearly 6 research papers in the areas of the sensors and transducers, network security and VLSI.

Badal Chakraborty received his Bachelor's degree in Electrical Engineering from National Institute of Technology; Agartala, India in 1998. He obtained his Master degree in Instrumentation and Control Engineering and Ph.D. (Tech) in Instrumentation and Measurement from University of Calcutta in 2000 and 2009 respectively. He completed his Post Doctoral work on Biomedical Engineering from Indian Institute of Science; Bangalore, India in 2010. He was working as a faculty member in Murshidabad College of Engineering and Technology from 2000 to 2005. He is currently faculty

member of Department of Post Harvest Engineering, Bidhan Chandra Krishi Viswavidyalaya, India. His research interest includes Sensors, Measurement, Biomedical Instrumentation and Application of electronics in agricultural fields. Dr.Chakraborty published more than 30 research papers in international and national journals. He is reviewer of so many international journals.