

Multiple Targets Classification and Fuzzy Logic Decision Fusion in Wireless Sensor Networks

Ahmad Aljaafreh

Abstract—This paper proposes a hierarchical hidden Markov model (HHMM) to model the detection of M vehicles in a wireless sensor network (WSN). The HHMM model contains an extra level of hidden Markov model to model the temporal transitions of each state of the first HMM. By modeling the temporal transitions, only those hypothesis with nonzero transition probabilities needs to be tested. Thus, this method efficiently reduces the computation load, which is preferable in WSN applications. This paper integrates several techniques to optimize the detection performance. The output of the states of the first HMM is modeled as Gaussian Mixture Model (GMM), where the number of states and the number of Gaussians are experimentally determined, while the other parameters are estimated using Expectation Maximization (EM). HHMM is used to model the sequence of the local decisions which are based on multiple hypothesis testing with maximum likelihood approach. The states in the HHMM represent various combinations of vehicles of different types. Due to the statistical advantages of multisensor data fusion, we propose a heuristic based on fuzzy weighted majority voting to enhance cooperative classification of moving vehicles within a region that is monitored by a wireless sensor network. A fuzzy inference system weighs each local decision based on the signal to noise ratio of the acoustic signal for target detection and the signal to noise ratio of the radio signal for sensor communication. The spatial correlation among the observations of neighboring sensor nodes is efficiently utilized as well as the temporal correlation. Simulation results demonstrate the efficiency of this scheme.

Keywords—Classification, decision fusion, fuzzy logic, hidden Markov model.

I. INTRODUCTION

RECENTLY Wireless Sensor Networks (WSNs) have become an emerging technology. The objective of WSNs is to monitor, control, or track objects, processes, or events [1]. Battlefield surveillance, border monitoring, and intelligent traffic system are some of the applications of the classification of ground vehicles based on acoustic signals using WSNs. Efficient classification and data fusion is a requirement for intelligent sensor networks. Many of the the recent researches tackle the problem of enhancing the performance of single target classification. Multiple moving vehicles classification as in Fig. 1 is a real challenge [2] because of the dynamicity and mobility of targets. The dynamicity of the targets refers to the evolution of the number of targets over time. Furthermore, limited observations, computational resources, finite power, and presence of communication constraints within and between the sensor nodes make it a more challenging problem. Multiple target classification is tackled in different ways as in Fig. 2. Target classification of multiple targets can be modeled as a Blind Source Separation (BSS) [3]

M. Aljaafreh is with the Department of Electrical Engineering, Tafila Technical University, Tafila, 66110 Jordan (e-mail: a.aljaafreh@ttu.edu.jo).

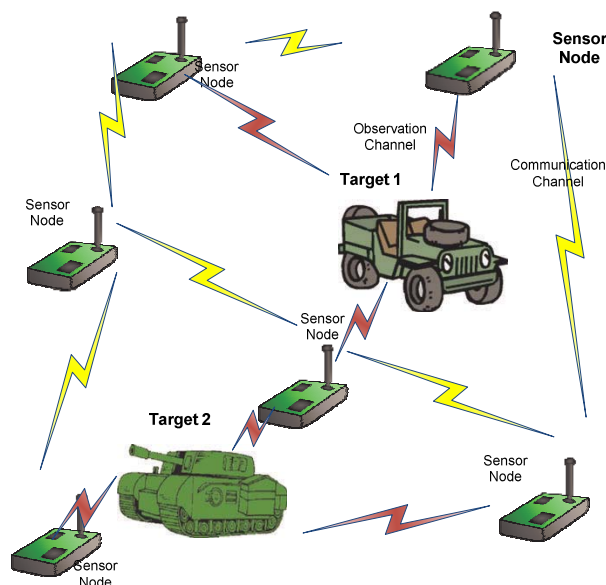

Fig. 1 Two vehicles passing an area monitored by a wireless sensor network

to separate or extract each signal of each vehicle then extract a feature vector then classify it. There are many techniques in the literature that are used to solve the BSS problem. However, all these techniques are hard to implement in WSNs because of the computational complexity. Classification of multiple targets without signals or sources separation based on multiple hypothesis testing is an efficient way of classification [4]. Ref. [5] proposed a distributed classifiers based on modeling each target as a zero mean stationary Gaussian random process and so the mixture signals.

In this paper a multi hypothesis test based on maximum likelihood is the base of the HHMM classifier. We assume that the maximum number of distinct vehicles that may exist in a sensing range of one sensor at the same time M is known. Based on this we consider each combination of M distinct vehicles and less as a one class. Then the number of hypotheses or classes is $N = 2^M$. N is exponentially increasing with M , to solve this problem HHMM is used to model the sequence of these hypotheses. For instance for $M = 2$ (vehicle type T and vehicle type W), the number of hypotheses is equal to 4 as in Fig. 3 namely: (00, 0T,

0W, TW). Then the branched HMM as in Fig 3 are used to model the distribution of the output of each hypothesis. Power consumption, resulting from data transmission, is greater than power consumption, resulting from data processing. This motivates people to consider decentralized data processing algorithms more than the centralized ones [6], [7]. In a distributed sensor network, each sensor node sends its local decision to the fusion center instead of sending the whole observation to save power and communication bandwidth as in Fig. 4. Recently, there are many researches in distributed detection and classification; however, most of them ignore the noises in the communication and observation channels and assume independent and identically distributed observations [8], [9]. In this paper, we consider the problem of decentralized classification of a stochastic signal for cluster based WSNs for non identically distributed observations. Because of the path of the sensing measurement, there will be a loss in the measurement power. This loss will make the Signal to Noise Ratio (SNR) of the farther node poor. Ref. [5] assumed that all the measurement from different nodes were independent and identically distributed (i.i.d). It is known that in reality these sensing measurements will not be identically distributed because of the sensing channel loss. Fig. 12 shows that there is an optimal radius around each sensor node over which decisions should be fused to get the minimum detection error. Ref. [10] analyzed the performance of centralized detection of a stochastic Gaussian signal in global power constrained wireless sensor networks. It is observed in Ref. [10] that, for global power constrained wireless sensor networks, there is an optimal number of sensor nodes that minimizes the detection fusion error probability, which depends on the signal to noise ratio for both the observation and the wireless communication channel. It is observed in this paper that even though the global power of the WSN is not constrained, there is an optimal number of sensor nodes for decision fusion to be performed. This is because of the decaying of the observed signal SNR as the target gets farther. Weights for every local decision of each sensor node is computed based on the SNR for both the observed signal and the wireless radio signal. In WSN, the Received Signal Strength Indication (RSSI) is used as a measure of the SNR of the wireless radio signal and the relative power of the acoustic signal emitted from the targets is used as a measure of the SNR of the acoustic signal.

The remainder of this paper is organized as follows. Section II formulates the problem mathematically. Section III describes modeling the problem as HHMM with GMM model. Section IV and Section V introduce and describe the fuzzy logic weighting algorithm. The state machine is described in Section VI. Simulation environment is described in Section VII. Section VIII presents the results and discussions. And finally conclusions are described in Section IX.

II. PROBLEM FORMULATION

We assume that the maximum number of distinct vehicles that may exist in one cluster region at the same time M is known. Then the number of hypotheses is $N = 2^M$,

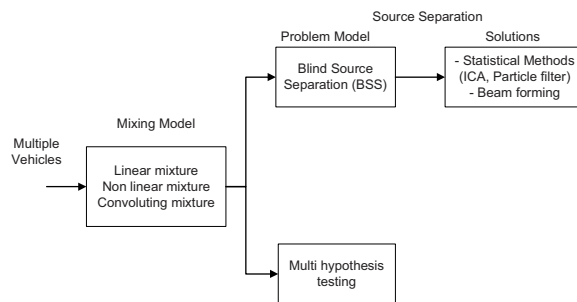

Fig. 2 A summary diagram of the techniques that are used in multiple vehicle classification using WSNs

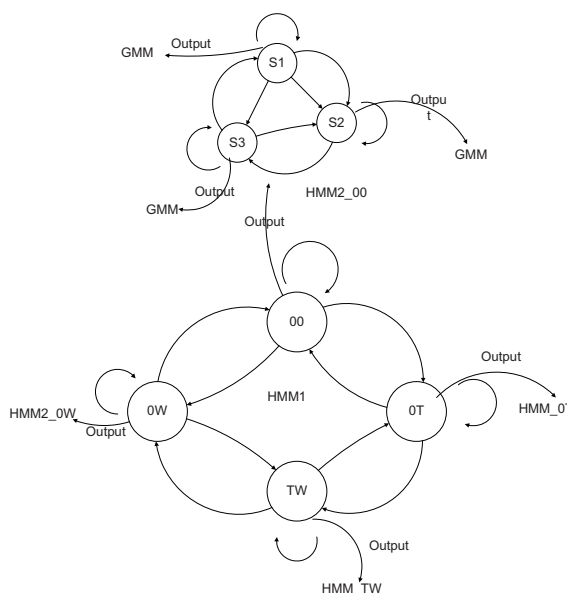

Fig. 3 The Hierarchical HMM

where the hypotheses correspond to the various possibilities for the presence or absence of different vehicles. Let h_i denote hypothesis i , $i = 0, \dots, N - 1$. Observation x_k is a feature vector obtained by a sensor node at time k . The feature vector can be related to the spectrum of a mixture of maximum M vehicle sounds. According to Bayes theorem, h_i is the maximum likelihood hypothesis given x_k , if $p(h_i|x_k) > p(h_j|x_k), \forall i \neq j$. So far, the decision about the hypothesis at any given event is based on the observation at that event without any relation with the previous observations as in [5].

$$d(h_{i_1}, h_{i_0}) = p(h_{i_1})p(x_i|h_{i_1}) \quad (7)$$

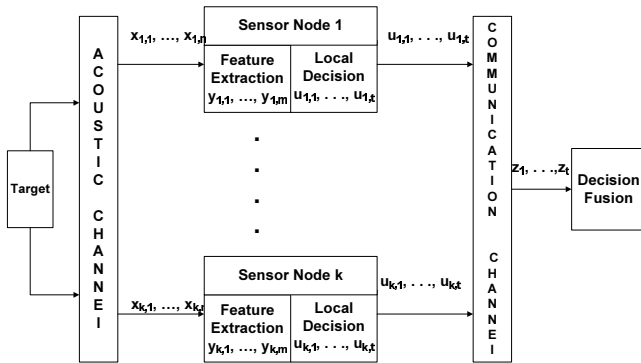

Fig. 4 Decentralized classification using k spatially distributed sensor nodes, X_i sequence is the observation in time domain for node i , where i is from 1 to k , k is the maximum number of sensor nodes, y_i is the sequence of the feature of the X_i . U_i and Z_i are the local decision without channel noise and with channel noise for time step i respectively

In fact, the class to which the feature vector x_i belongs to also depends on the previous event class. The classification decision at any instant of time depends on the previous decision and the current observation. Therefore, the classification problem is a context dependent problem and it can be modeled by HMM. In context-dependant Bayesian classification, a sequence of decisions is needed instead of a single one, and the decisions depend on each other. Let $X : \{x_1, x_2, \dots, x_t\}$ be a sequence of feature vectors of observations. And let $H_i : \{h_{i1}, h_{i2}, \dots, h_{it}\}$ be a sequence of classes. According to Bayes theorem, X is classified to H_i if

$$p(H_i|X) > p(H_j|X), \forall i \neq j. \quad (1)$$

$$p(H_i|X) (><) p(H_j|X) \equiv p(X|H_i)p(H_i) (><) p(X|H_j)p(H_j) \quad (2)$$

where $(><)$ denotes comparing and \equiv denotes equivalent to. According to the Markov chain model,

$$p(H_i) = p(h_{i1}) \prod_{k=2}^N p(h_{ik}|h_{i_{k-1}}) \quad (3)$$

We assume that $\{x_i\}$ are mutually independent and so are the probability distributions of the classes. Therefore,

$$p(X|H_i) = \prod_{k=1}^N p(x_k|h_{ik}) \quad (4)$$

Based on Eq. 2, 3, and 4, we have

$$p(X|H_i)p(H_i) = p(h_{i1})p(x_1|h_{i1}) \prod_{k=2}^N p(h_{ik}|h_{i_{k-1}})p(x_k|h_{ik}) \quad (5)$$

We define the probability of transition from hypothesis h_{i_k} to hypothesis $h_{i_{k-1}}$ as $d(h_{i_k}, h_{i_{k-1}})$

$$d(h_{i_k}, h_{i_{k-1}}) = p(h_{i_k}|h_{i_{k-1}})p(x_k|h_{i_k}) \quad (6)$$

Feature vector of observation of each class i is modeled as a HMM with GMM output distribution. The maximum revenue corresponds to the optimal path. The hypotheses along the optimal path result in the observation sequence X . Based on Bellman's principle the cost in Equations (6) and (7) can be computed online.

Each sensor nodes processes the observation to get the local decision then sends this decision to a fusion center where a collective decision is made. In this research we relaxed the assumption that the independent observed signals from different sensors nodes is identically distributed. The observed signal to noise ratio depends on the distance between the target and the underlying sensor node. Assuming that the power of the independent noises for the neighbor sensor nodes are identical, then the power of the observed signal will be poorer as the target becomes farther from the underlying sensor node. Based on this, there will be an optimal radius around the fusion center over which the fusion will be performed. Each local decision should be weighted to have a better contribution on the final decision to minimize the detection error probability. Suppose that a binary hypothesis testing situation where the hypothesis are denoted by H_0 and H_1 . H_1 denotes the presence of the target signal. The target is modeled here as a zero mean Gaussian stochastic process. The Gaussian observed signal is denoted by S_n . S_n is characterized by its covariance matrix $S_n \sim N(0, \Sigma_s)$. H_0 denotes the noise ν . ν is a white Gaussian noise characterized by its covariance matrix, $\nu \sim N(0, \Sigma_\nu)$, assuming that the noises are independent at different sensor nodes then $\sigma_\nu = \sigma_\nu^2 \mathbf{I}$. So the observation vector for node k is X_k as in Fig. 4 can be written as follows:

$$\begin{aligned} H_1 & : X_k = a_n S_k + \nu_k \\ H_0 & : X_k = \nu_k, k = 1, \dots, N \end{aligned}$$

where N is the number of sensor nodes and a_n is the attenuation factor for the observed signal.

$$a_n = \frac{1}{10^{\frac{\alpha p_i}{20}}} \quad (8)$$

where p_i is the distance between sensor node i and the moving vehicle. α is the attenuation factor for unit distance [11]. The value of α is determined by the Atmospheric Sound Absorbption Calculator [12]. The problem is to define the minimum p_i for each sensor node to have a beneficial contribution in the decision fusion.

$$\begin{aligned} Z_k & = b_k X_k + \omega_k \\ Z_k & = b_k a_k S_k + b_k \nu_k + \omega_k \end{aligned}$$

Where Z_n is the radio received signal, ω_n is the receiver white Gaussian noise $\omega \sim N(0, \sigma_\omega^2 \mathbf{I})$, and b_n is the attenuation factor of the radio signal. Based on the above, the covariance matrices for both the noise and the original signal will be changed as the following:

$$\Sigma_z = b_k^2 a_k^2 \Sigma_s + b_k^2 \sigma_\nu^2 \mathbf{I} + \sigma_\omega^2 \mathbf{I} \quad (9)$$

$$\Sigma_{\omega} = (b_k^2 \sigma_{\nu}^2 + \sigma_{\omega}^2) \mathbf{I} \quad (10)$$

Thus the decision variable for the optimal fusion rules is as follows:

$$T(\mathbf{z}) = \mathbf{z}^T (\Sigma_{\omega}^{-1} - \Sigma_z^{-1}) \mathbf{z} \quad (11)$$

$$= \mathbf{z}^T ((b_k^2 \sigma_{\nu}^2 + \sigma_{\omega}^2) \mathbf{I}^{-1} - (b_k^2 a_k^2 \Sigma_s + b_k^2 \sigma_{\nu}^2 \mathbf{I} + \sigma_{\omega}^2 \mathbf{I})^{-1}) \mathbf{z} \quad (12)$$

The decision will be based on comparing the decision variable T with a certain threshold. According to Eq. (11), the distance between the two distributions will be decreased as a_n and/or b_n decrease, because the attenuation factors a_n and b_n are both less than one. This makes the decision accuracy decline, as the attenuation factors decrease. Thus, each local decision should be weighted according to the signal to noise ratio for both acoustic signal and the wireless radio signal. Eq. (12) shows how hard it is to model the decision weights based on both SNRs mathematically. Therefore, we use fuzzy inference system to weight each local decision.

III. HIDDEN MARKOV MODEL (HMM)

Acoustic signals could be modeled as HMM. HMM has a specific discrete number of unobserved states; each state has a transition probability to any other state and an initial probability. Each state may be considered as representing a certain sound of the vehicle [13]. Ref. [13] models the cepstral coefficients that are obtained from the time domain signal as HMM, where the pdfs of the states are assumed to be Gaussian with non zero means and with a diagonal covariance matrix. Modeling the vehicle sounds as HMM is based on the assumption that the acoustic signal of the vehicle is consisting of a sequence of a discrete number of sounds, where the statics of each sound of these sounds is described by a separate state. The parameters of the HMM are: the state transition probability to any other state, the initial probability for each state, and the observation pdf parameters for each state. Estimation of the maximum likelihood parameters of the HMM given a data set of the vehicle sounds can be done by a special case of the Expectation maximization algorithm called the Baum Welch algorithm; it is also known as the forward backward algorithm. HMM implementation for vehicle classification is based on the estimation of the sequence of states, given a sequence of observations. Some known algorithms are used for that such as the Viterbi algorithm. GMM is static pattern model, while HMM is a sequential pattern model.

A. Hierarchical Hidden Markov Model (HHMM)

In this paper, we propose a classification scheme that is based on HHMM. The states in the HHMM contain another HMM which represents a time sequence of the vehicle acoustic signals. The branched HMM represents the distribution of the output of the HHMM as in Fig. 3, where it models the features of the continuous acoustic emissions. The output of the states of the branched HMM is modeled as Gaussian Mixture Model (GMM), where the number of states and the number of Gaussians are experimentally determined. The

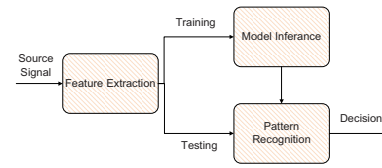

Fig. 5 Main block diagram of pattern recognition

other parameters of the second HMM are estimated using Expectation Maximization (EM). The HHMM is used to model the sequence of the local decisions which are based on multiple hypothesis testing with maximum likelihood approach. The states in the first HMM represent various combinations of vehicles of different types. Thus the number of the states of the HHMM equals $N = 2^M$. The number of hypotheses that need to tested at any time step is equal to $M + 1$. The HHMM utilizes the correlation between the sequence of decisions and decreases the computational complexity.

B. Gaussian Mixture Model (GMM)

Due to the constraints in WSN resources, parametric models such as Gaussian mixture model is preferred to non parametric models [14]. Modeling of acoustic signal in WSN using a parametric model, like GMM requires little resources, and has a good pattern matching performance [14]. GMM is a statistical method that is used for classification and clustering. GMM is a linear combination of M Gaussian pdfs. Let \mathbf{x} be a N dimensional feature vector, then the distribution of \mathbf{x} is as follows:

$$f_m(\mathbf{x}) = \sum_{i=1}^m \alpha_i \phi(\mathbf{x}; \theta_i) \quad (13)$$

where $\sum_{i=1}^m \alpha_i = 1$, $\alpha_i \geq 0 : i \in 1, \dots, m$

α_i is the mixing weight, $\phi(\mathbf{x}; \theta_i)$ is the Gaussian mixture component. Component i has N variate Gaussian density function with weight α_i , mean vector μ_i , and covariance matrix Σ_i .

Expectation maximization (EM) is one of the common algorithm that is used to obtain the GMM parameters $\Phi_i = (\alpha_i, \mu_i, \Sigma_i)$ from the training set. The GMM generated from the training set will be used in vehicle classification as in Fig. 5.

GMM is used as a classifier in WSN based on the features that are extracted from the vehicle sounds in [14]. Ref. [14] concludes that the GMM, as a parametric classifier, outperforms the k nearest neighbor algorithm (KNN) and the support vector machine (SVM) classifiers, and it also concludes that GMM needs relatively less resources.

IV. FUZZY LOGIC INFERENCE

Fuzzy logic inference is a simple approach to solving a problem rather than attempting to model it mathematically. Empirically, the fuzzy logic inference depends on human's

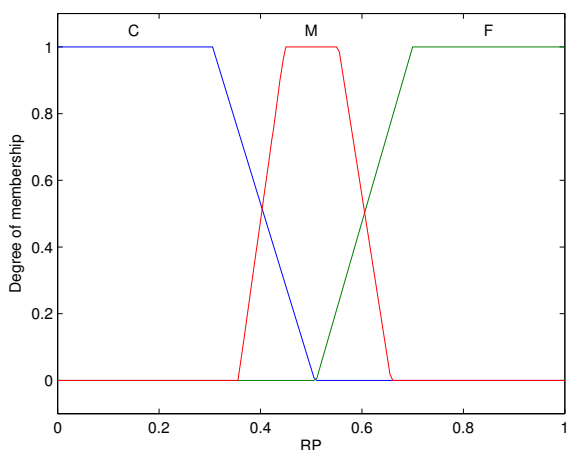

Fig. 6 The membership functions of the input variable RP, they are the same for input variable SB

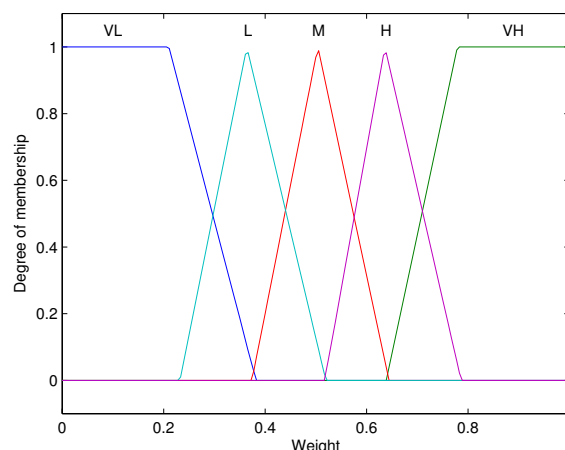

Fig. 7 The membership functions of the weight.

experience more than the technical understanding of the problem. Fuzzy logic inference consists of three stages:

- 1) Fuzzification: map any input to a degree of membership in one or more membership functions, the input variable is evaluated in term of the linguistic condition.
- 2) Fuzzy inference: fuzzy inference is the calculation of the fuzzy output.
- 3) Defuzzification: defuzzification is to convert the fuzzy output to a crisp output.

V. FUZZY WEIGHTED MAJORITY VOTING

Majority voting is a simple way to combine decisions of several classifiers or decision makers to improve the recognition process. We refer the reader to [15] to understand how and why the majority voting can improve the recognition process. Fuzzy logic is used for weighting the local decisions according to both observation SNR as well as wireless radio SNR to minimize the decision fusion probability of error. Fuzzy logic is applied in decision fusion to benefit from the human logic. The fuzzy decision weighting system consists of two inputs: The relative sensing signal power (SP), and the relative Received Signal Strength Indication ($RSSI$) of the wireless radio signal (RP). The three membership functions of the two fuzzy logic inputs SP and RP are shown in Fig. 6. The inputs are defined by the following membership functions: C (*Close*), M (*Medium*), and F (*Far*). The output of the fuzzy logic, the weight of each local decision W , is defined by four membership functions very low (VL), low (L), Medium (M), High (H), and Very High(VH). Fig. 7 shows these membership functions. The fuzzy logic rules are deduced as in Table I. The centroid method is used for defuzzification. W is shown as a function of SP and RP in Fig. 8.

VI. STATE MACHINE DECISION MAKING

The position and the speed of each target will not be estimated in this paper. However, the position and speed of the group will be estimated based on the propagation of the

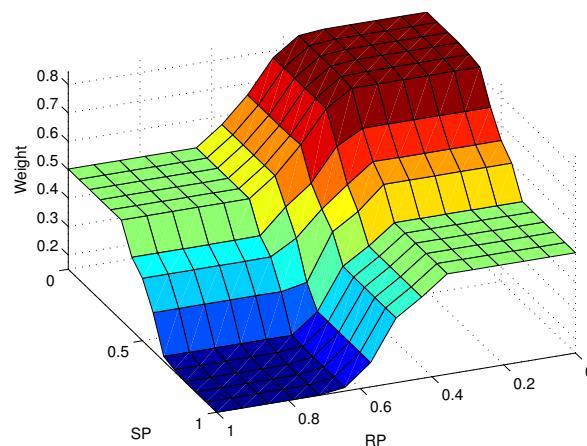

Fig. 8 The weight as a functions of the input variables RP and SB after defuzzification

acoustic signal without association. Each cluster head will keep track of the state of the targets and decide whether the targets are closing in or going far from the fusion center according to the power of the acoustic signal for each sensor node at each time step. Although a cluster head takes the decision every time step, it just sends its decision to the gateway or sink one time. The best time to send this decision

TABLE I
FUZZY RULES FOR FUZZY WEIGHTING

Index	Input 1 SP	Operator	Input 2 RP	Rule weight	Output
1	C	and	C	1	VH
2	F	and	F	1	VL
3	M	and	M	1	M
4	C	and	F	1	M
5	F	and	C	1	M
6	M	and	F	1	L
7	F	and	M	1	L
8	M	and	C	1	H
9	C	and	M	1	H

is when the targets are as close as possible to the cluster center. This time will be determined by the state machine as in Fig. 9. We grouped sensor nodes to two groups: group one, and group two. Group one is the J sensor nodes with the highest acoustic signal power. Group two is the closest J sensor nodes to the cluster center. Suppose ξ is the difference of the sum of the acoustic power of group one and group two.

$$\xi = \sum_1^J P_{groupOne} - \sum_1^J P_{groupTwo} \quad (14)$$

Then, if ξ is decreasing, then the vehicles are closing toward the center of the cluster. If ξ is increasing, then the vehicles are going far a way from the center of the cluster. By this we can know the direction and the position of the vehicles in that specific cluster. Tracking ξ with time will lower the detection false alarm, because of the motion detection besides the acoustic signal detection. The speed can be estimated from the rate of the difference Δ , where $\Delta = \xi_i - \xi_{i-1}$.

In ideal cases, If the targets are heading toward the center of the cluster then Δ sign will not change. In reality, because of the noise and the random motion of the vehicles, the sign of Δ may fluctuate. Therefore, we introduced the four counting states as in Fig. 9. These four counters $\{CIF, CIC, CTF, CTC\}$ will be reset in any transition to any other state. State Count_To_Get_Far counts the number of time steps that Δ has the negative sign. If the counter (CTF) is greater than (M) the state will be changed to Get_Far state, which assures that Δ is steady and the vehicles keep getting far. If the sign of Δ is changed while the system in state Get_Far then the fusion center will change the state to Count_In_Get_Far. State Count_In_Get_Far counts the number of time steps that Δ has the negative sign. If the counter (CIF) is greater than (L) the state will be changed to Count_To_Get_Far state. This also applies for other states. $\{K, L, M, N\}$ are determined experimentally. The state machine keeps tracking the region of the high acoustic power. This will enable the fusion center to know if this detection is false or not from the changing of the region of the highest acoustic power. This algorithm can be applied for position estimation, speed estimation, as well as target tracking.

VII. SIMULATION ENVIRONMENT

We developed our simulation environment using Matlab for one network cluster region (300×300) as in Fig. 10. Where this cluster consist of a grid of different numbers of sensor nodes. Sensing range for all sensor nodes will be the same. Sensing range is chosen to enable all sensor nodes in one cluster region to observe the same targets with different attenuation. The sensing range is represented by a radius of a circle. When any target enters this circle, the simulator will pick a random real life vehicle sound according to the vehicle type. Where the vehicle type and number are chosen randomly. Then this sound will be attenuated based on the distance between the target and the sensor node. After that, a mixture is linearly formed based on the number of targets. Then each sensor node extracts the feature from the acoustic

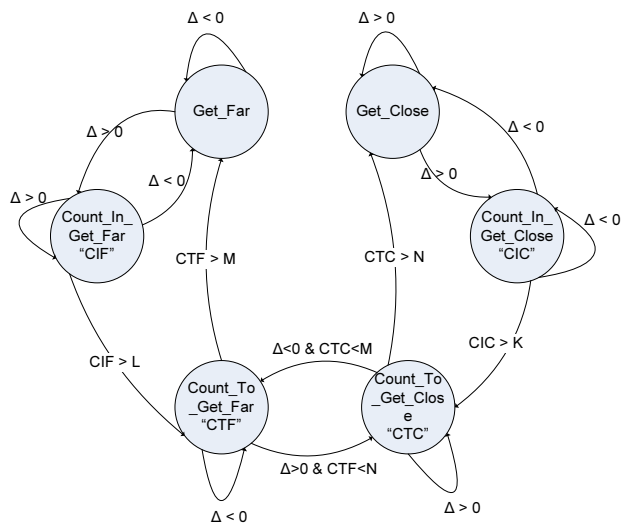

Fig. 9 States machine diagram of the targets position relative to the center of the cluster

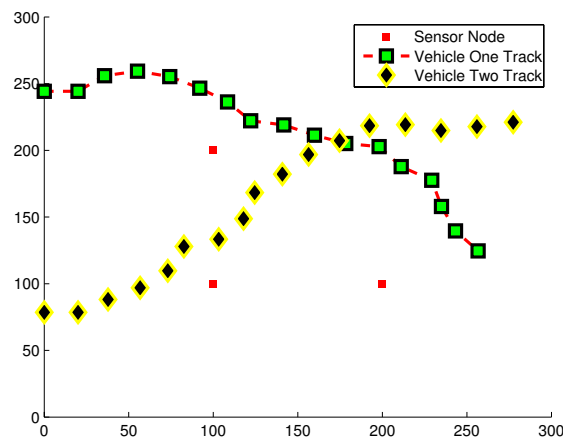

Fig. 10 Four sensors in one cluster simulation region

signal based on discrete spectrum. This mixture is classified by each sensor node. The classification decision is sent to the manger node where decision fusion will be accomplished. Sensor nodes are deployed uniformly as in Fig. 10.

The simulator is built such that multiple targets enter the region of simulation from one direction. Entry location and entry angle are selected randomly. Targets speed and directions are modeled according to Gauss Markov mobility model. Gauss Markov mobility model parameters are chosen such that to avoid sharp updates in speed and direction. Each sensor node calculates the maximum likelihood state based on HHMM at every discrete time t . State transition cost as in equation (6) is calculated only for states that have nonzero transition probability, then the maximum of all cost is corresponded to the maximum likelihood state or hypothesis.

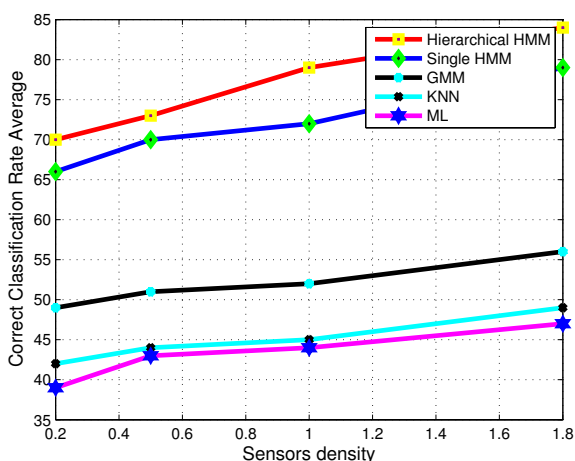

Fig. 11 Classification rates for different classifiers versus the density of the network

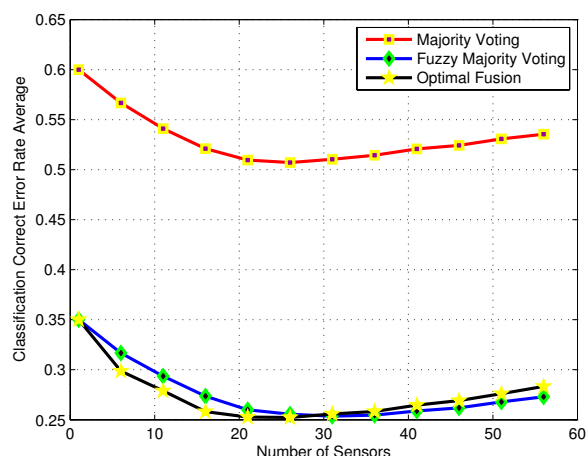

Fig. 12 The relation between correct classification error rate and the number of sensor for optimal data fusion, majority voting, and fuzzy majority voting cooperative algorithm for a fixed number of sensor per square meter(0.0016)

VIII. RESULTS AND DISCUSSIONS

Simulation in this paper is based on real life vehicle sounds that is available at <http://www.ece.wisc.edu/sensit>. Fig.11 displays the result of running the simulator hundreds of times. Our experiment is conducted for two distinct vehicles. Simulation results that are shown in Fig.11 show that the correct classification rate increases with the sensor density in different kind of classifiers. It is clear that this rate is the highest in the case of HHMM classifier. The classification rates are based on k fold cross validation. Fig.11 shows how efficient is the HHMM compare to other classifiers. The most important benefit of HHMM over normal HMM classifier is the reduction in the computation overhead for multiple hypothesis testing approach. Because the only hypotheses that need to be tested are the ones that have nonzero state transition probability. For distinct targets, the number of hypothesis are 2^M where M is the maximum number of targets that can be exist within the sensor range at the same time. In our approach, only $M + 1$ hypothesis need to be tested at each time step.

The classification decision and acoustic power are sent to the cluster head where the decision fusion is performed. All the local decisions are fused by a fuzzy weighted majority voting algorithm. In the classical majority voting algorithm, all the local decisions of the sensor nodes have the same weight regardless of the observation SNR and wireless RSSI. While in the fuzzy weighted majority voting decision fusion algorithm, each local decision of the sensor node has been assigned a different weight based on the observation SNR and wireless RSSI. The result of simulation is shown in Fig. 12. The fuzzy majority voting achieves less minimal point of detection error average than the normal majority voting. Since farther sensor nodes have less weight, this makes sharing many sensor nodes in the decision does not increase the error in the fuzzy majority voting. This means that, if the optimal number of the involved sensor nodes in the decision fusion is unknown or can not be determined, the least detection error can be obtained if the fuzzy weighted majority voting decision fusion is used. The correct fuzzy rules are deduced based on experiment results.

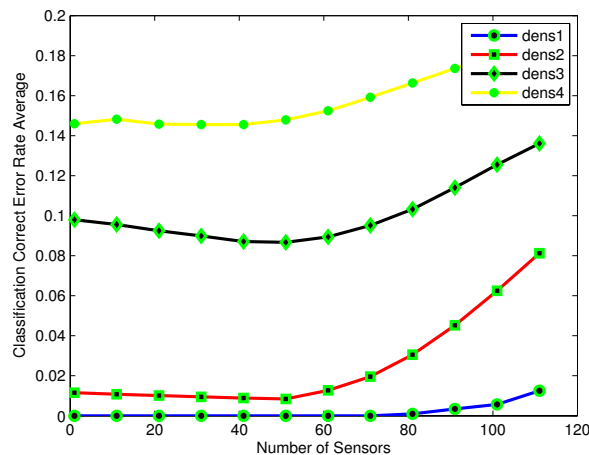

Fig. 13 The relationship between correct classification error rate and the number of sensor for fuzzy majority voting cooperative algorithm for four distinct sensor's densities dens1=0.0008, dens2=0.0006, dens3=0.0005, and dens4=0.0004 sensors per square meter

Thus the rules should be changed as the network parameters change. Fig. 12 shows that the error of our fusion scheme is very close to the optimal fusion method, which is based on the sum of the probabilities of all the hypotheses. The optimal method is equivalent to the data fusion where each sensor node send the feature vector to the fusion center, then the fusion center find the highest sum of all hypotheses probabilities . Fig.13 shows the detection error average for four different densities. To have the detection error decrease as the number of sensors increases until having the least detection error, the right fuzzy logic rules should be deduced.

IX. CONCLUSIONS

A Hierarchical Hidden Markov Model is proposed in this paper as a classifier to classify multiple vehicle using wireless sensor network. Classification problem of multiple dynamic

vehicles in WSNs can be modeled as a context dependant classification problem. The states in the HHMM contain another HMM which models the vehicle acoustic signals. The number of moving vehicles of each type is considered as the state, and each state depends on the previous state. This makes it appropriate to model the system with HMM. Simulation results based on real vehicle sounds show that using HHMM increases the correct classification rate. The other benefit of HHMM is the reduction of the computation overhead for multiple hypothesis testing. The only hypotheses that need to be tested depend on the state transition probabilities, therefore the hypotheses that need to be tested are the ones that have none zero transition probabilities. In our scheme the only hypotheses that need to be tested is $M + 1$ out of 2^M , where M is the maximum number of targets that can be exist within the sensor range at the same time. A new on line decision fusion method is developed for moving targets in wireless sensor networks, where a fuzzy inference system is developed to determine the weights for each local decision based on the signal to noise ratios for the sensing signals and the wireless radio signals. This is also integrated with a state machine to help in deciding when to take the best decision for the whole cluster and to know the direction and speed of the targets. Simulation results demonstrate the efficiency of this method. However, it is computationally more expensive than the classical majority voting method.

- [15] L. Lam and S. Suen, "Application of majority voting to pattern recognition: an analysis of its behavior and performance," *Systems, Man and Cybernetics, Part A: Systems and Humans*, IEEE Transactions on, vol. 27, no. 5, pp. 553–568, Sep 1997.

REFERENCES

- [1] M. Winkler, K.-D. Tuchs, K. Hughes, and G. Barclay, "Theoretical and practical aspects of military wireless sensor networks," *Journal of Telecommunications and Information Technology*, pp. 37–45, 2008.
- [2] M. N. Raghavendra, "Collaborative classification applications in sensor networks," 2002.
- [3] T.-Y. Sun, C.-C. Liu, S.-J. Tsai, and S.-T. Hsieh, "Blind source separation with dynamic source number using adaptive neural algorithm," *Expert Syst. Appl.*, vol. 36, no. 5, pp. 8855–8861, 2009.
- [4] E. Drakopoulos, J. J. Chao, , and C. C. Lee, "A two-level distributed multiple hypothesis decision system," vol. 37, no. 3, pp. 380–384, Mar. 1992.
- [5] J. H. Kotecha, V. Ramachandranand, and A. M. Sayeed, "Distributed multitarget classification in wireless sensor networks," vol. 23, no. 4, pp. 703–824, Apr. 2005.
- [6] D. Hall and J. Llinas, "An introduction to multisensor data fusion," *Proceedings of the IEEE*, vol. 85, no. 1, pp. 6–23, Jan 1997.
- [7] R. Viswanathan and P. Varshney, "Distributed detection with multiple sensors i. fundamentals," *Proceedings of the IEEE*, vol. 85, no. 1, pp. 54–63, Jan 1997.
- [8] S. Jayaweera, "Bayesian fusion performance and system optimization for distributed stochastic gaussian signal detection under communication constraints," *Signal Processing, IEEE Transactions on*, vol. 55, no. 4, pp. 1238–1250, April 2007.
- [9] Q. Tian and E. Coyle, "Optimal distributed detection in clustered wireless sensor networks," *Signal Processing, IEEE Transactions on*, vol. 55, no. 7, pp. 3892–3904, July 2007.
- [10] S. Jayaweera, "Decentralized detection of stochastic signals in power-constrained sensor networks," in *Signal Processing Advances in Wireless Communications, 2005 IEEE 6th Workshop on*, June 2005, pp. 270–274.
- [11] B. Malhotra, I. Nikolaidis, and J. Harms, "Distributed classification of acoustic targets in wireless audio-sensor networks," *Comput. Netw.*, vol. 52, no. 13, pp. 2582–2593, 2008.
- [12] "http://kidsvid.altec.org", "Atmospheric sound absorption calculator," 2009.
- [13] W. J. Roberts, H. W. Sabrin, and Y. Ephraim, "Ground vehicle classification using hidden markov models," in *Atlantic coast technologies Inc., Silver Spring MD*, 2001.
- [14] Y. Kim, S. Jeong, D. Kim, and T. S. López, "An efficient scheme of target classification and information fusion in wireless sensor networks," *Personal Ubiquitous Comput.*, vol. 13, no. 7, pp. 499–508, 2009.