

Fuzzy Logic Control of a Semi-Active Quarter Car System

Devdutt, M. L. Aggarwal

Abstract—The development of vehicles having best ride comfort and safety of travelling passengers is of great interest for automotive manufacturers. The effect of transmitted vibrations from car body to passenger seat is required to be controlled for achieving the same. The application of magneto-rheological (MR) shock absorber in suspension system has been considered to achieve significant benefits in this regard. This paper introduces a secondary suspension controlled semi-active quarter car system using MR shock absorber for effective vibration control. Fuzzy logic control system is used for design of controller for actual damping force generation by MR shock absorber. Performance evaluations are done related to passenger seat acceleration and displacement in time and frequency domains, in order to see the effectiveness of the proposed semi-active suspension system. Simulation results show that the semi-active suspension system provides better results compared to passive suspension system in terms of passenger ride comfort improvement.

Keywords—Fuzzy logic control, MR shock absorber, Quarter car model, Semi-active suspension system.

I. INTRODUCTION

SUSPENSION system can be classified into three groups such as passive, semi-active and active based upon the performance delivered in the vehicle system during travelling period. Though the technology related to passive suspension system is simple and less costly but its performance is limited to certain frequency range due to the damping behavior of uncontrollable shock absorber. Active suspension systems can perform ride performance and vehicle handling related task in a wider frequency range making it an attractive choice for vehicle manufacturers. But certain requirements in terms of cost, high power demand for system working and many sensors and controllers makes this technology limited to certain costly vehicles. On the other hand, semi-active suspension system related technology offers a good solution in terms of enhanced performance compared to passive suspension system while requiring simple and cheap technology compared to active suspension system. Due to these favorable reasons, semi-active suspension related technology has attracted many researchers and industries in last few decades [1]-[2].

In past, a large number of control strategies such as neural network control [3], fuzzy logic control [4], H-infinity control

[5], skyhook control [6] and LQG control [7] has been studied for making the semi-active suspension system technology practically feasible. Despite of many attractive features, the main hindrance in the application of MR shock absorber in vehicle system is its hysteretic and highly non-linear dynamic nature during working period. Thus, for development and application of proper control system in semi-active suspension technology, modeling of this unpredictable nature of MR shock absorber is very crucial. Recently, several models have been developed by researchers to properly trace or follow this behavior of MR shock absorber. These models include Bouc-Wen hysteresis model [8], viscoelastic-plastic model [9], fuzzy model [10], polynomial model [11] and other models [12], [13]. In present case, polynomial model is selected since it is an easy and effective model which can be applied for control system development to be implemented in semi-active suspension system technology for proper working of assembled MR shock absorber.

The aim of this paper is to present a fuzzy logic algorithm to improve the passenger ride comfort and safety during travelling period using the quarter car model with three-degrees-of-freedom and to compare the performance of semi-active vehicle system assembled with MR shock absorber compared to one with traditional uncontrolled passive shock absorber.

II. MODELING OF TEST RESULTS

MR shock absorber selected here for implementation in semi-active vehicle system is from Lord Corporation and named as RD-1005-3. The total extended and compressed length of the device is 208mm and 155mm respectively with stroke length of ± 25 mm. The current requirement for its continuous working is up to 1 Amp. while the maximum current should not exceed 2 Amp. for safe working. MR shock absorber testing was conducted using MTS machine to obtain the measured force-displacement and force-velocity curves at different current values. The test result curves and polynomial model fitted curves are shown in Fig. 1, showing very close matching with each other thus showing the effectiveness of selected model for controller development. The calculated values of the coefficients b_i and c_i from fitted curves are listed in Table I.

Devdutt is research scholar in Mechanical Engineering Department, YMCA University of Science and Technology, Faridabad, Haryana, India (phone: 91-129-4198100, fax: 91-129-4198444, e-mail: devdutt.ymca@gmail.com).

Dr. M.L. Aggarwal is Professor in Mechanical Engineering Department, YMCA University of Science and Technology, Faridabad, Haryana, India. (e-mail: aggarwalmlal@rediffmail.com)

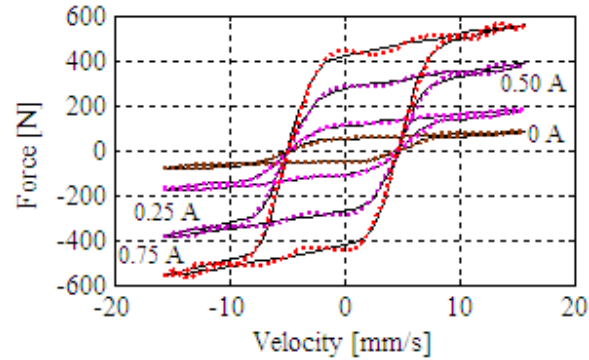

Fig. 1 Comparison of model fitted curves (colored dash lines) and experimental results (solid line), 1 Hz, ± 2.5 mm: force versus velocity diagram

TABLE I
COEFFICIENTS b_i AND c_i OF THE POLYNOMIAL MODEL

Positive acceleration				Negative acceleration			
Coefficients		Coefficients		Coefficients		Coefficients	
b_0	-22.18	c_0	-549.39	b_0	22.47	c_0	543.95
b_1	0.99	c_1	2.59	b_1	3.09	c_1	-2.20
b_2	0.33	c_2	15.36	b_2	-5.64E-01	c_2	-13.07
b_3	0.12	c_3	3.93	b_3	7.44E-02	c_3	3.71
b_4	-6.84E-04	c_4	-1.38E-01	b_4	7.99E-03	c_4	7.13E-02
b_5	-1.55E-03	c_5	-7.25E-02	b_5	-1.28E-03	c_5	-6.29E-02
b_6	-1.96E-05	c_6	3.65E-04	b_6	-6.38E-05	c_6	3.18E-04
b_7	8.71E-06	c_7	5.62E-04	b_7	8.62E-06	c_7	4.51E-04
b_8	1.19E-07	c_8	6.60E-07	b_8	2.63E-07	c_8	-3.52E-06
b_9	-2.21E-08	c_9	-1.99E-06	b_9	-2.66E-08	c_9	-1.48E-06
b_{10}	-1.75E-10	c_{10}	-3.05E-09	b_{10}	-4.25E-10	c_{10}	7.26E-09
b_{11}	2.25E-11	c_{11}	2.63E-09	b_{11}	3.11E-11	c_{11}	1.84E-09

III. QUARTER CAR MODEL

In present study, for comparative analysis of vehicle systems, a quarter car suspension model is considered as shown in Fig. 2 while the parameters selected for simulation purpose are shown in Table II.

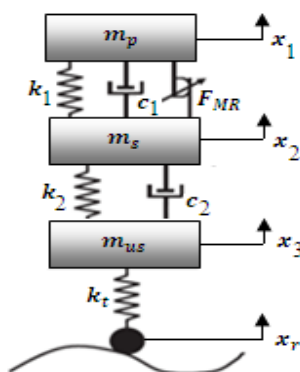

Fig. 2 Quarter car model

By taking into account the vertical dynamics of the model, the derived equations of motion for the passenger seat mass, sprung and unsprung masses of the quarter car suspension system are given in (1)-(3) as follows:

$$m_p \ddot{x}_1 + k_1(x_1 - x_2) + c_1(\dot{x}_1 - \dot{x}_2) + F_{MR} = 0 \quad (1)$$

$$m_s \ddot{x}_2 - k_1(x_1 - x_2) - c_1(\dot{x}_1 - \dot{x}_2) + k_2(x_2 - x_3) + c_2(\dot{x}_2 - \dot{x}_3) - F_{MR} = 0 \quad (2)$$

$$m_{us} \ddot{x}_3 - k_2(x_2 - x_3) - c_2(\dot{x}_2 - \dot{x}_3) + k_t(x_3 - x_r) = 0 \quad (3)$$

where x_1 , x_2 , x_3 and x_r denotes the passenger seat displacement, sprung mass displacement, unsprung mass displacement and road profile displacement respectively for the quarter car model while F_{MR} is the additional damping force generated by MR shock absorber.

TABLE II
PARAMETERS OF QUARTER CAR MODEL

Passenger seat mass, m_p	75 kg
Sprung mass, m_s	320 kg
Unsprung mass, m_{us}	45 kg
Primary suspension damping, c_2	1500 N/m/s
Secondary suspension damping, c_1	750 N/m/s
Primary suspension stiffness, k_2	25000 N/m
Secondary suspension stiffness, k_1	8000 N/m
Tire stiffness, k_t	180,000 N/m

IV. CONTROLLER DESIGN

In this work, fuzzy logic control algorithm is used for vibration suppression of the semi-active suspension system. This algorithm was first proposed by Lotfi Zadeh [14] and emerging as a powerful tool for control system applications in

mechatronic based devices. The concerned Fuzzy controller is assembled between the passenger seat and sprung mass of the vehicle. The inputs supplied to this controller are passenger seat velocity (V_p) and secondary suspension system velocity (V_{rel}) while the output supplied from it is desired damping force (F_d).

The considered input and output variables for fuzzy logic controller are defined with 5 linguistic grades as: PL (Positive Large), PM (Positive Medium), S (Small), NM (Negative Medium) and NL (Negative Large) respectively. The designed membership function plots are shown in Fig. 3 while the written rule base for this controller working is presented in Table III.

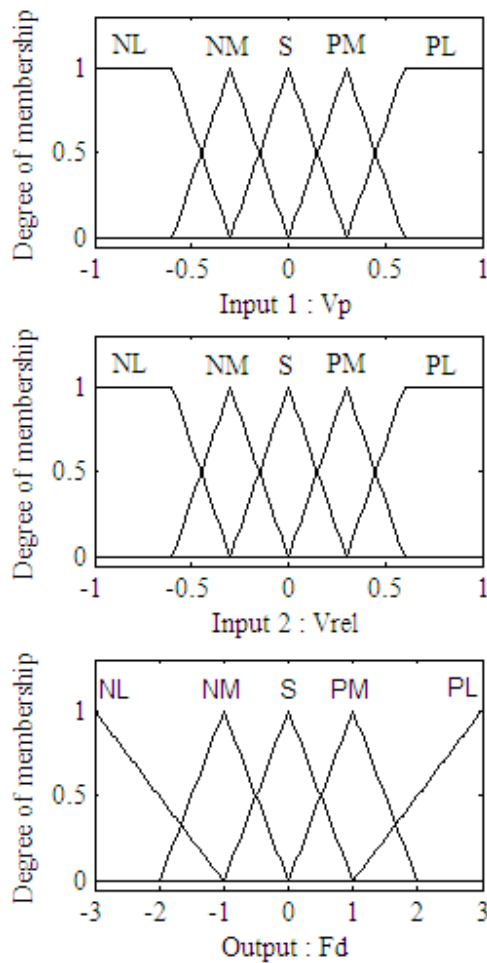

Fig. 3 Membership function curves for FLC

TABLE III
 FUZZY RULE BASE

V_{rel}/V_p	NL	NM	S	PM	PL
NL	PL	PL	PL	PM	S
NM	PL	PL	PM	S	NM
S	PL	PM	S	NM	NL
PM	PM	S	NM	NL	NL
PL	S	NM	NL	NL	NL

Here, Mamdani method is applied in fuzzy inference system while the output from controller is based on the operators like “Min” implication and “Max” aggregation. Centroid method is used for transformation of resultant linguistic data into mathematical numerals. For obtaining exact magnitudes of the defined variables, scaling factor is used.

V.SIMULATION RESULTS

The performance evaluation of the designed quarter car system is evaluated using Simulink/Matlab software under bump road profile as shown in Fig. 4 (a). Bump road input is most commonly encountered profile for travelling vehicles and can be represented by upper positive profile of single sinusoidal curve. It generally acts as a shock input having different height from place to place such as highway road or crowded road as per safety requirement for road walking people. Since it is unpredictable and suddenly comes in way of running vehicle giving very short time for the driver to react, this can be very harmful to the vehicle body and travelling passengers. The response of the uncontrolled and controlled systems plotted in terms of passenger seat acceleration, passenger seat displacement and suspension deflection are shown in Figs. 4 (b)-(d), respectively. Fig. 4 (e) shows the desired damping force signal for the MR shock absorber. It can be observed from Figs. 4 (b)-(d) that the controlled semi-active quarter car model provides better performance in terms of controlling the response of considered parameters as compared to uncontrolled suspension system in time domain.

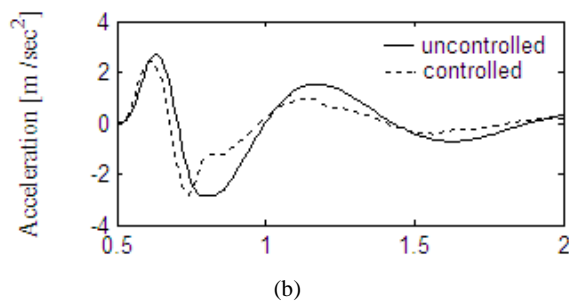
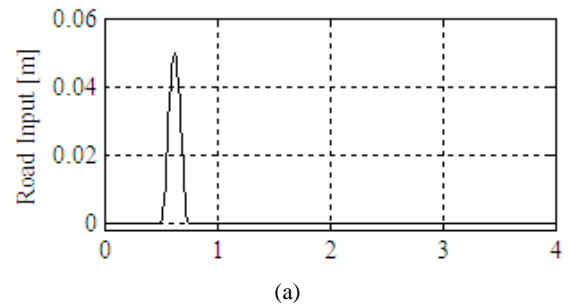

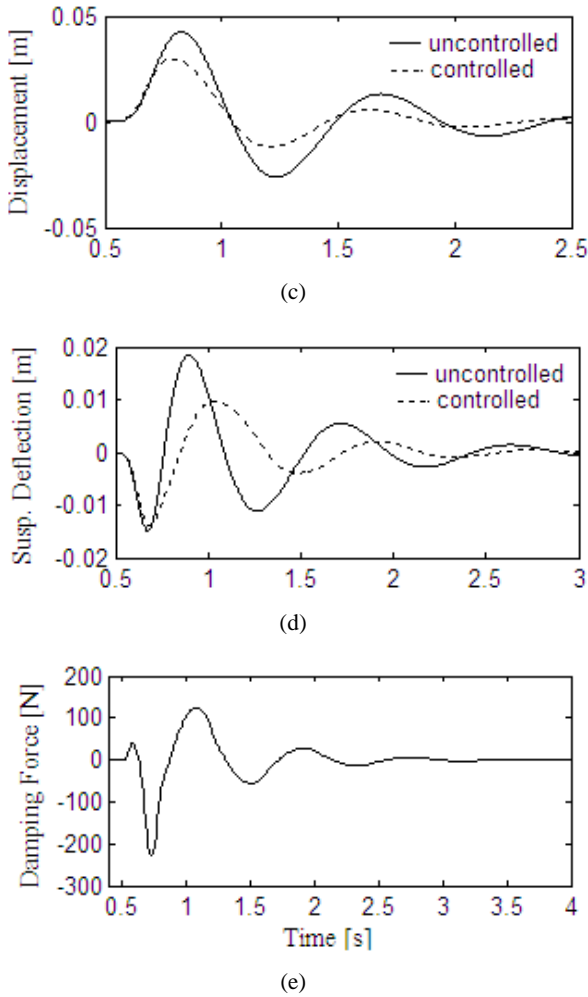

Fig. 4 (a) bump profile road input, (b) passenger seat acceleration, (c) passenger seat displacement, (d) secondary suspension deflection, (e) desired damping force

TABLE IV

RMS VALUES FOR QUARTER CAR MODEL AT 40 KM/HR

Parameter	Uncontrolled	Controlled	Improvement
a_1 (ms^{-2})	0.7888	0.5686	27.91%
x_1 (m)	0.0118	0.0075	36.44%
x_1-x_2	0.0052	0.0036	30.76%

TABLE V

MAX. VALUES FOR QUARTER CAR MODEL AT 40 KM/HR

Parameter	Uncontrolled	Controlled	Improvement
a_1 (ms^{-2})	2.7215	2.4045	11.64%
x_1 (m)	0.0426	0.0297	30.28%
x_1-x_2	0.0185	0.0097	47.56%

The root-mean-square (RMS) values of the response plots are presented in Table IV while the maximum (Peak) values are shown in Table V. It can be seen from Tables IV and V that the controlled semi-active suspension system with MR shock absorber provides good performance in terms of passenger seat acceleration (a_1), passenger seat displacement (x_1) and secondary suspension deflection (x_1-x_2) compared to that of uncontrolled suspension system.

Figs. 5 (a)-(c) show the bode plots of passenger seat acceleration, velocity and displacement respectively. Since the quarter car model considered for analysis purpose is having three degrees of freedom resulting into generation of three frequencies. Here, the main criterion selected is related to passenger seat response, so frequency response plots of it are taken into account while neglecting the frequency responses of sprung mass and unsprung mass. It can be seen from Figs. 5 (a)-(c) that the passenger seat acceleration, velocity and displacement characteristics of controlled suspension system are improved as compared to uncontrolled suspension system.

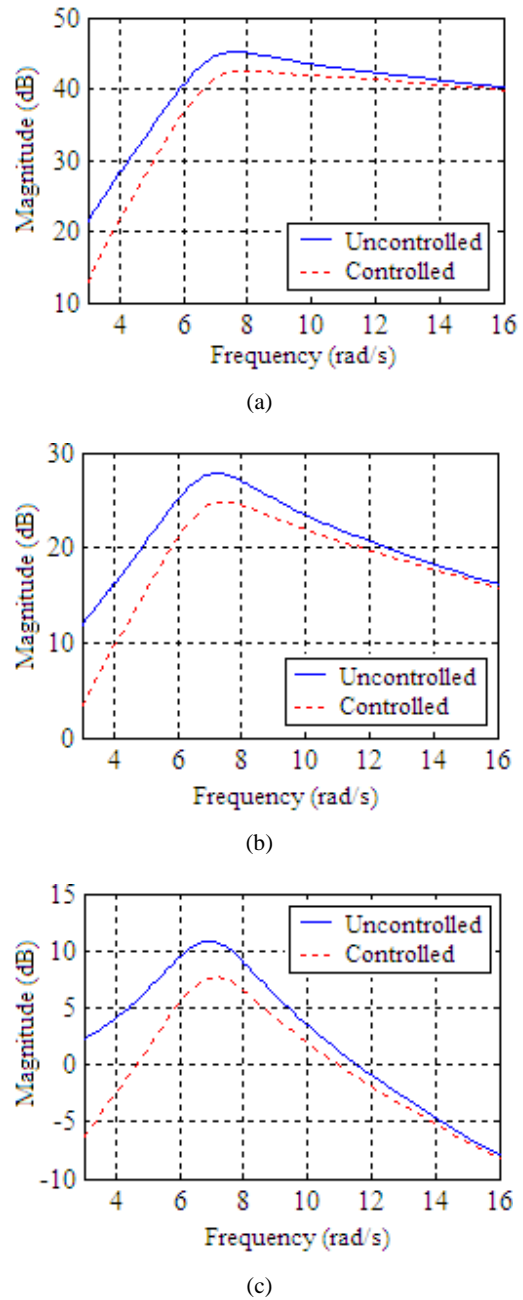

Fig. 5 Frequency response plots of passenger seat (a) acceleration, (b) velocity and (c) displacement

VI. CONCLUSION

A quarter car model with three degree of freedom subjected to bump road excitation has been used in this study to compare the passenger ride performance of controlled and uncontrolled vehicle systems. The semi-active suspension is integrated with Fuzzy Logic Controller in combination with MR shock absorber. It can be concluded from the time domain and frequency domain results of passenger seat response that controlled semi-active system provide better ride comfort and safety to travelling passengers than a passive or uncontrolled vehicle system. Thus the selected control strategy can be applied in semi-active suspension system to achieve desired performance practically in automotive sector.

REFERENCES

- [1] A. Giua, C. Seatzu, and G. Usai, "Semiactive suspension design with an Optimal Gain Switching target", *Vehicle System Dynamics*, Vol. 31, 213–232, 1999.
- [2] K. J. Kitching, D. J. Cole, and D. Cebon, "Performance of Semi-Active Shock absorber for Heavy Vehicles", *ASME Journal of Dynamic Systems Measurement and Control*, Vol.122, 498-506, 2000.
- [3] D. L. Guo, H. Y. Hu, and J. Q. Yi, "Neural network control for a semi-active vehicle suspension with a magnetorheological damper", *J. Vib. Control*, Vol. 10, Issue 3, 461–471, 2004.
- [4] Fang, X. et al., "Fuzzy control technology and the application to vehicle semi-active suspension", *Chinese J. Mech. Eng.*, Vol. 35, Issue 3, 98–100, 1999.
- [5] S.B. Choi, H.S. Lee, and Y.P. Park, "H-infinity control performance of a full-vehicle suspension featuring magnetorheological dampers", *Veh. Syst. Dyn.*, Vol. 38, Issue 5, 341–360, 2002.
- [6] D. Karnopp, M. J. Croby, and R. A. Harwood, "Vibration control using semi-active force generators", *ASME Journal of Engineering for Industry*, Vol. 96, Issue 2, 619–626, 1974.
- [7] M. M. ElMadany and Z. S. Abduljabbar, "Linear quadratic Gaussian control of a quarter car suspension", *Vehicle System Dynamics*, Vol. 32, Issue 6, 479–497, 1999.
- [8] B. F. Spencer Jr., S. J. Dyke, M. K. Sain, and J. D. Carlson, "Phenomenological model for magnetorheological dampers", *Journal of Engineering Mechanics*, Vol. 123, Issue 3, 230–238, 1997.
- [9] N. M. Wereley, Li Pang, and G. M. Kamath, "Idealized hysteresis modelling of electrorheological and magnetorheological dampers", *Journal of Intelligent Material Systems and Structures*, Vol. 9, Issue 8, 642–649, 1998.
- [10] K.C. Schurter and P.N. Roschke, "Fuzzy modelling of a magnetorheological damper using ANFIS", in: *Proceedings of the IEEE International Conference on Fuzzy Systems*, 122–127, 2000.
- [11] S.B. Choi, S.K. Lee and Y.P. Park, "A hysteresis model for the field-dependent damping force of a magnetorheological damper", *Journal of Sound and Vibration*, Vol. 245, Issue 2, 375–383, 2001.
- [12] L. Alvarez and R. Jimenez, "Real-time identification of magnetorheological dampers", in: *Proceedings of 15th IFAC*, 2252–2258, 2002.
- [13] C. Chang and L. Zhou., "Neural network emulation of inverse dynamics for a magnetorheological damper", *J. Struct. Eng. ASCE*, Vol. 128, 231–239, 2002.
- [14] Zadeh L.A., *Fuzzy sets*, *Information and Control*, 8: 338–353, 1965.