

The Effect of Nonnormality on CB-SEM and PLS-SEM Path Estimates

Z. Jannoo, B. W. Yap, N. Auchoybur, M. A. Lazim

Abstract—The two common approaches to Structural Equation Modeling (SEM) are the Covariance-Based SEM (CB-SEM) and Partial Least Squares SEM (PLS-SEM). There is much debate on the performance of CB-SEM and PLS-SEM for small sample size and when distributions are nonnormal. This study evaluates the performance of CB-SEM and PLS-SEM under normality and nonnormality conditions via a simulation. Monte Carlo Simulation in R programming language was employed to generate data based on the theoretical model with one endogenous and four exogenous variables. Each latent variable has three indicators. For normal distributions, CB-SEM estimates were found to be inaccurate for small sample size while PLS-SEM could produce the path estimates. Meanwhile, for a larger sample size, CB-SEM estimates have lower variability compared to PLS-SEM. Under nonnormality, CB-SEM path estimates were inaccurate for small sample size. However, CB-SEM estimates are more accurate than those of PLS-SEM for sample size of 50 and above. The PLS-SEM estimates are not accurate unless sample size is very large.

Keywords—CB-SEM, Monte Carlo simulation, Normality conditions, Nonnormality, PLS-SEM.

I. INTRODUCTION

THE most common approach to Structural Equation modeling (SEM) is the Covariance-Based SEM (CB-SEM). Another unique approach to SEM is the partial least squares SEM (PLS-SEM). These methodologies have been applied widely in fields such as marketing and consumer behavior [1], [2], management [3], and psychology [4]. The CB-SEM allows us to test how well the model fits the data and it aims at minimizing the difference between the model covariance matrix and the sample covariance matrix which is obtained from the observed manifesting variables [5], [6]. CB-SEM requires a set of stringent assumptions such as normality of data and adequate sample size. When these assumptions for CB-SEM are not met, the alternative approach to PLS-SEM [7], [8] is used. The PLS-SEM makes use of a series of ordinary least squares (OLS) regression to maximize the variance explained for the endogenous constructs.

Simulation studies have investigated the statistical advantage of PLS-SEM *vis à vis* small sample size [9]-[12].

Z. J. is with the Centre for Statistical and Decision science studies, Faculty of Computer and Mathematical Sciences, University of Technology MARA (UiTM), 40450 Shah Alam, Selangor, Malaysia (phone: 6016-328-1502; e-mail: zeinabjannoo@gmail.com).

B. W. Y and M. A. L are with the Centre for Statistical and Decision science studies, Faculty of Computer and Mathematical Sciences, University of Technology MARA (UiTM), 40450 Shah Alam, Selangor, Malaysia (e-mail: beewah@tmsk.uitm.edu.my, dralias@tmsk.uitm.edu.my).

N. A. is with the Economics and Statistics department, Faculty of Social Studies and Humanities, University of Mauritius, Reduit, Mauritius (e-mail: n.auchoybur@uom.ac.mu).

However, the debate on whether PLS-SEM performs better under small sample size and non-normal conditions compared to CB-SEM is still on-going in deciding which SEM techniques perform better [13]. There are numerous softwares for modeling data using CB-SEM and PLS-SEM. Some of the most common softwares for CB-SEM are LISREL [14], AMOS [15], EQS [16], and MPLUS. On the other hand, the PLS path modeling software includes SmartPLS [17] and PLS-Graph (Soft Modeling Inc 1992-2002). Generally, the structural equation model consists of a set of endogenous and exogenous constructs which are measured by manifesting variables. SEM, usually considered as a second-generation technique, allows the simultaneous modeling of relationships among multiple endogenous and exogenous variables [11].

In CB-SEM, the default parameter estimation method is the maximum likelihood (ML) although there are other estimation methods such as the generalized least squares, weighted least squares and the asymptotically distribution free (ADF) methods. The ML is normally preferred when the data to be analyzed is normal since it yields unbiased estimates [18]. CB-SEM requires sufficient sample size. Given the asymptotic property of the ML estimation, a minimum sample size is required to generate results of sufficient accuracy. Many researchers make use of the simple approach of the “rule of 5” (ratio of a sample size to the number of parameters to be estimated) under the normal distribution theory or the “rule of 10” to obtain appropriate significance tests [19]. On the other hand, [6] suggested that a minimum sample size of 100-150 is sufficient for a model with five or less constructs with each constructed having more than 3 indicators. The assumption of normality cannot be met in most empirical research. Some simulation studies have investigated that given non-normality conditions, CB-SEM was quite robust [20]-[23]. However, [11] proposed that when the sample size is small and the data is non-normal, PLS-SEM is a better approach.

PLS-SEM originated from H. Wold [24] under the name NIPALS (nonlinear iterative partial least squares) and focuses on maximizing the variance of the endogenous constructs explained by the exogenous constructs instead of reproducing the empirical covariance matrix [18]. It works with both reflective and formative indicators. The reflective indicators have error terms unlike the formative ones. PLS-SEM makes use of the OLS regression-based approach to estimate the path coefficients and the bootstrapping technique to obtain the standard error and to test the paths significance. PLS-SEM is well-suited when CB-SEM has limitations of sample size and distributional assumption. The PLS-SEM structural model reflects the relationships between the latent variables and a

measurement component; it also consists of a third component, the weight relations which are used to estimate the latent variables [13]. A Monte Carlo simulation study demonstrated that PLS can still produce meaningful results even at small sample size such as 20 [13]. One rule-of-thumb is that the sample size should be greater or equal to ten times the number of indicators and also ten times the largest number of arrows pointing to a particular latent variable [25]. Since PLS-SEM is a non-parametric technique, it does not impose distributional assumptions [26]. The only one requirement which needs to be fulfilled is that all the linear OLS regressions must be equal to the conditional expectation of the dependent constructs [24]. The discussion of sample size and normality assumptions is still on-going among researchers and more simulation studies are needed to compare between CB-SEM and PLS-SEM.

This paper focuses on a comparison of CB-SEM and PLS-SEM under normal and nonnormal conditions. Section II reviews the theoretical background of CB-SEM and PLS-SEM. The simulation design is explained in Section III and the results are presented in Section IV. Some recommendations and conclusion are given in Section V.

II. REVIEW OF THE THEORY OF CB-SEM AND PLS-SEM

A. CB-SEM

Consider random vectors $\boldsymbol{\eta} = (\eta_1, \eta_2, \dots, \eta_m)$ and $\boldsymbol{\xi}' = (\xi_1, \xi_2, \dots, \xi_n)$ of latent dependent and independent variables, respectively, and the following system of linear structural relations [18], [22], [27]:

$$\boldsymbol{\eta} = \mathbf{B} \boldsymbol{\eta} + \boldsymbol{\Gamma} \boldsymbol{\xi} + \boldsymbol{\zeta} \quad (1)$$

where $\mathbf{B}(m \times m)$ and $\boldsymbol{\Gamma}(m \times n)$ are coefficient matrices and $\boldsymbol{\zeta}' = (\zeta_1, \zeta_2, \dots, \zeta_m)$ is a random vector of residuals (errors in equations, random disturbance terms). The elements of \mathbf{B} represent direct causal effects of η variables on other η variables and the elements of $\boldsymbol{\Gamma}$ represent direct causal effects of ξ variables on η variables. It is assumed that $\boldsymbol{\zeta}$ is uncorrelated with $\boldsymbol{\xi}$ and that $\mathbf{I} - \mathbf{B}$ is nonsingular.

The vectors $\boldsymbol{\eta}$ and $\boldsymbol{\xi}$ are not observed; instead vectors $\mathbf{y}' = (y_1, y_2, \dots, y_p)$ and $\mathbf{x}' = (x_1, x_2, \dots, x_q)$ are observed such that

$$\mathbf{y} = \boldsymbol{\Lambda}_y \boldsymbol{\eta} + \boldsymbol{\varepsilon} \quad (2)$$

and

$$\mathbf{x} = \boldsymbol{\Lambda}_x \boldsymbol{\xi} + \boldsymbol{\delta} \quad (3)$$

where $\boldsymbol{\varepsilon}$ and $\boldsymbol{\delta}$ are vectors of errors of measurement in \mathbf{y} and \mathbf{x} , respectively. The matrices $\boldsymbol{\Lambda}_y(p \times m)$ and $\boldsymbol{\Lambda}_x(q \times n)$ are regression matrices of \mathbf{y} on $\boldsymbol{\eta}$ and of \mathbf{x} on $\boldsymbol{\xi}$ respectively. It is convenient to refer to \mathbf{y} and \mathbf{x} as the observed variables and $\boldsymbol{\eta}$

and $\boldsymbol{\xi}$ as the latent variables. The errors of measurement are assumed to be uncorrelated with $\boldsymbol{\eta}$, $\boldsymbol{\xi}$, and $\boldsymbol{\zeta}$, but may be correlated among themselves.

In CB-SEM, the Maximum Likelihood (ML) estimation method is usually employed to give parameter estimates such that the covariance matrix of the theoretical model, $\boldsymbol{\Sigma}$ is as close as possible to the sample covariance matrix \mathbf{S} . The ML estimates are obtained by means of an iterative procedure which minimizes a definite fitting function by successively improving the parameter estimates starting with the initial estimates [27]-[30]. Using ML, the fitting or likelihood function is:

$$F = \log|\boldsymbol{\Sigma}| + \text{tr}(\mathbf{S}\boldsymbol{\Sigma}^{-1}) - \log|\mathbf{S}| - (p+q) \quad (9)$$

where for a square matrix \mathbf{A} , $|\mathbf{A}|$ denotes the determinant of \mathbf{A} , $\text{tr}(\mathbf{A})$ denotes the sum of the diagonal elements of \mathbf{A} and $(p+q)$ is the total numbers of manifest variables (indicators). The fitting function for ML is derived from the maximum likelihood principle based on the assumption that the observed variables have a multinormal distribution.

B. PLS-SEM

In PLS-SEM, the model is separated into two sub-models, the measurement or outer model (relationships between manifest variables and their associated latent variables) and the structural or the inner model (relationships between latent variables).

The PLS algorithm [31] consists of an iterative procedure of OLS regressions and starts with the initialization (or outer approximation) stage whereby the latent variables are approximated by a linear combination of their manifesting variables. The set of weights is determined using an approach similar to principal component analysis for reflective indicators and regression analysis for formative indicators. The second step is the inner approximation followed by the outer approximation where the best linear combination is found to express each latent variable by means of its manifesting variable and its coefficients are known as outer weights. Then step 4 consists of calculating the factor scores. After each step, the latent variables are scaled to have zero mean and unit variance.

The Step 1 (initialization) is described as follows:

Let the manifesting variables (MVs), $\mathbf{X}_1, \dots, \mathbf{X}_k$ have mean(\mathbf{X}_i) = 0 and VAR(\mathbf{X}_i) = 1. All weights are set equal to one. The latent variables (LVs) are scaled to have unit variance.

$$\hat{\mathbf{Y}} = \mathbf{X}\mathbf{M} \quad (10)$$

$$\hat{y}_g = \frac{\hat{y}_g}{\sqrt{\text{VAR}(\hat{y}_g)}}, \quad g = 1, \dots, G \quad (11)$$

where \mathbf{M} is the adjacency matrix and the LVs are initialized as $\hat{\mathbf{Y}} = (\hat{y}_1, \dots, \hat{y}_G)$.

In Step 2, the inner approximation comprises of estimating each LV as a weighted sum of its neighbouring LVs. Here, the weighting technique depends on the applied weighting scheme. The LVs are now computed again to ensure unit variance.

$$\tilde{\mathbf{Y}} = \hat{\mathbf{Y}}\mathbf{E} \quad (12)$$

$$\tilde{y}_g = \frac{\hat{y}_g}{\sqrt{\text{VAR}(\hat{y}_g)}}, \quad g = 1, \dots, G \quad (13)$$

The inner estimation is obtained by $\tilde{\mathbf{Y}} = (\tilde{y}_1, \dots, \tilde{y}_G)$.

In outer approximation, initially all weights are set equal to one, and the weights are recalculated based on weighing scheme. The weights depend on the measurement mode; Mode A (Reflective measurement) and Mode B (Formative measurement). In Mode A, the block of MVs is the response and the LV is the regressor:

$$\hat{\mathbf{w}}_g^T = (\tilde{\mathbf{y}}_g^T \tilde{\mathbf{y}}_g)^{-1} \tilde{\mathbf{y}}_g^T \mathbf{X}_g \\ = \text{COR}(\tilde{\mathbf{y}}_g, \mathbf{X}_g) \quad (14)$$

In Mode B, the multiple regression coefficient is written with the LV as the response and its block of MV as regressors:

$$\hat{\mathbf{w}}_g = (\mathbf{X}_g^T \mathbf{X}_g)^{-1} \mathbf{X}_g^T \tilde{\mathbf{y}}_g \\ = \text{VAR}(\mathbf{X}_g)^{-1} \text{COR}(\mathbf{X}_g, \tilde{\mathbf{y}}_g) \quad (15)$$

In this study only the reflective indicators were used (Mode A).

In Step 4, the factor scores are calculated. The outer weights vectors, $\mathbf{w}_1, \dots, \mathbf{w}_G$ are arranged in an outer weights matrix \mathbf{W} . Equations (16) and (17) result in the outer estimation of the latent variables, $\hat{\mathbf{Y}} = (\hat{y}_1, \dots, \hat{y}_G)$.

$$\hat{\mathbf{Y}} = \mathbf{X}\mathbf{W} \quad (16)$$

$$\hat{y}_g = \frac{\hat{Y}_g}{\sqrt{\text{VAR}(\hat{Y}_g)}}, \quad g = 1, \dots, G \quad (17)$$

Step 5 is an iterative step. The estimation of the factor scores in Step 4 is taken to be final if the relative change of all the outer weights from one iteration to the next is smaller than a predefined tolerance:

$$\left| \frac{\hat{w}_{kg}^{old} - \hat{w}_{kg}^{new}}{\hat{w}_{kg}^{new}} \right| < \text{tolerance} \quad (18) \\ \forall k = 1, \dots, K, \wedge g = 1, \dots, G$$

The weighting scheme is used for the estimation of the inner weights of the PLS algorithm. According to the

weighting scheme using centroid, the matrix of inner weights \mathbf{E} is as follows:

$$e_{ij} = \begin{cases} \text{sign}(r_{ij}) & , \text{ for } c_{ij} = 1 \\ 0 & , \text{ else} \end{cases}, \quad i, j = 1, \dots, G \quad (19)$$

III. SIMULATION DESIGN

The Monte Carlo simulation procedures were used to compare the performance of CB-SEM and PLS-SEM in terms of the standardized path estimates. Fig. 1 shows the true standardized estimates of the model employed by [20]. Firstly, data were generated from a standard normal distribution for the latent constructs and the residuals. The model consisted of one endogenous and four exogenous constructs each having three indicators. The standardized loadings of each three reflective indicators were 0.70, 0.80 and 0.90 respectively. Then, the nonnormality conditions were set by generating data for the indicator variables using Chi-Square distribution with 2 degrees of freedom. This particular distribution accounted for a skewness of 1.983 and a kurtosis of 4.375.

Thus, random observations from both random normal and Chi-square distributions were generated for various sample sizes. This study considered sample sizes (n) of 20, 40, 90, 150 and 200 conforming to the study by [20]. The minimum sample size of n=20 was based on the “rule of 5” and n = 40 pertained to the “rule of 10”. The simulation was replicated 500 times for both CB-SEM and PLS-SEM. The standardized path estimates were extracted for both CB-SEM and PLS-SEM. For comparing between CB-SEM and PLS-SEM, box-plots were created and 95% confidence intervals were obtained. This simulation was carried out using R (A Programming Environment for Data Analysis and Graphics). The “lavaan” package [32] was used to perform CB-SEM and the “semPLS” package [33] was adopted for the PLS-SEM approach.

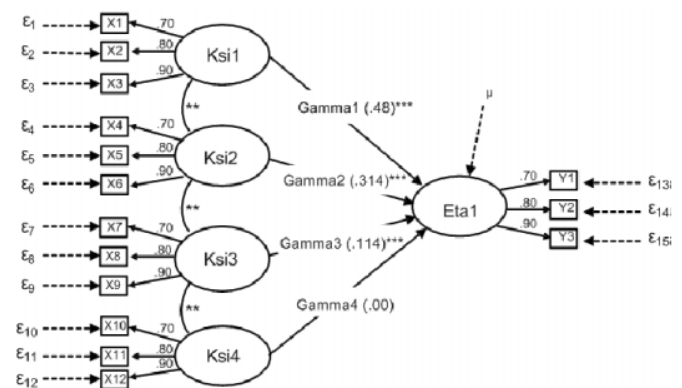

Fig. 1 Theoretical model with true standardized path estimates

TABLE I
 BOX-PLOTS FOR CB-SEM AND PLS-SEM FOR NORMAL DISTRIBUTION

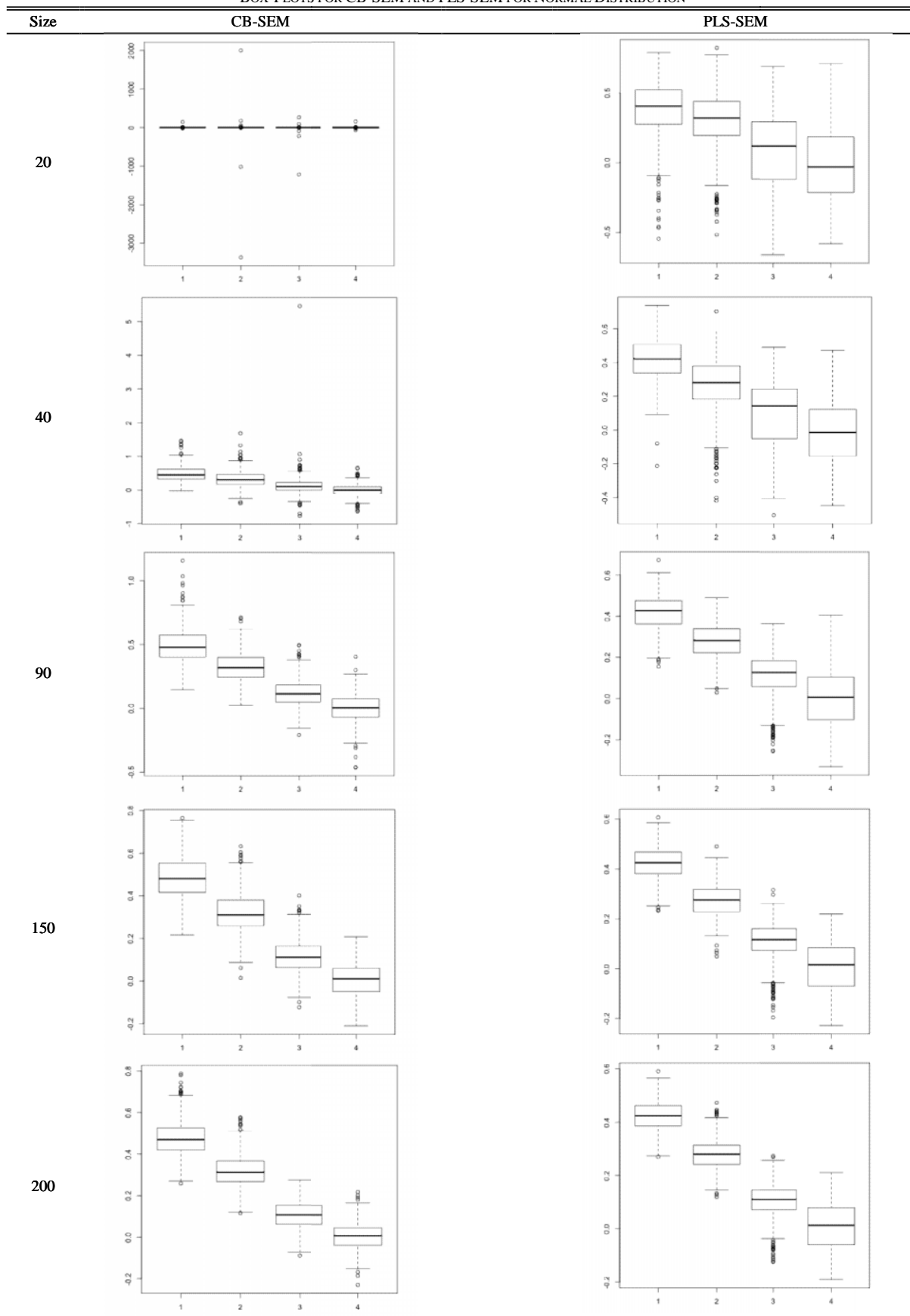
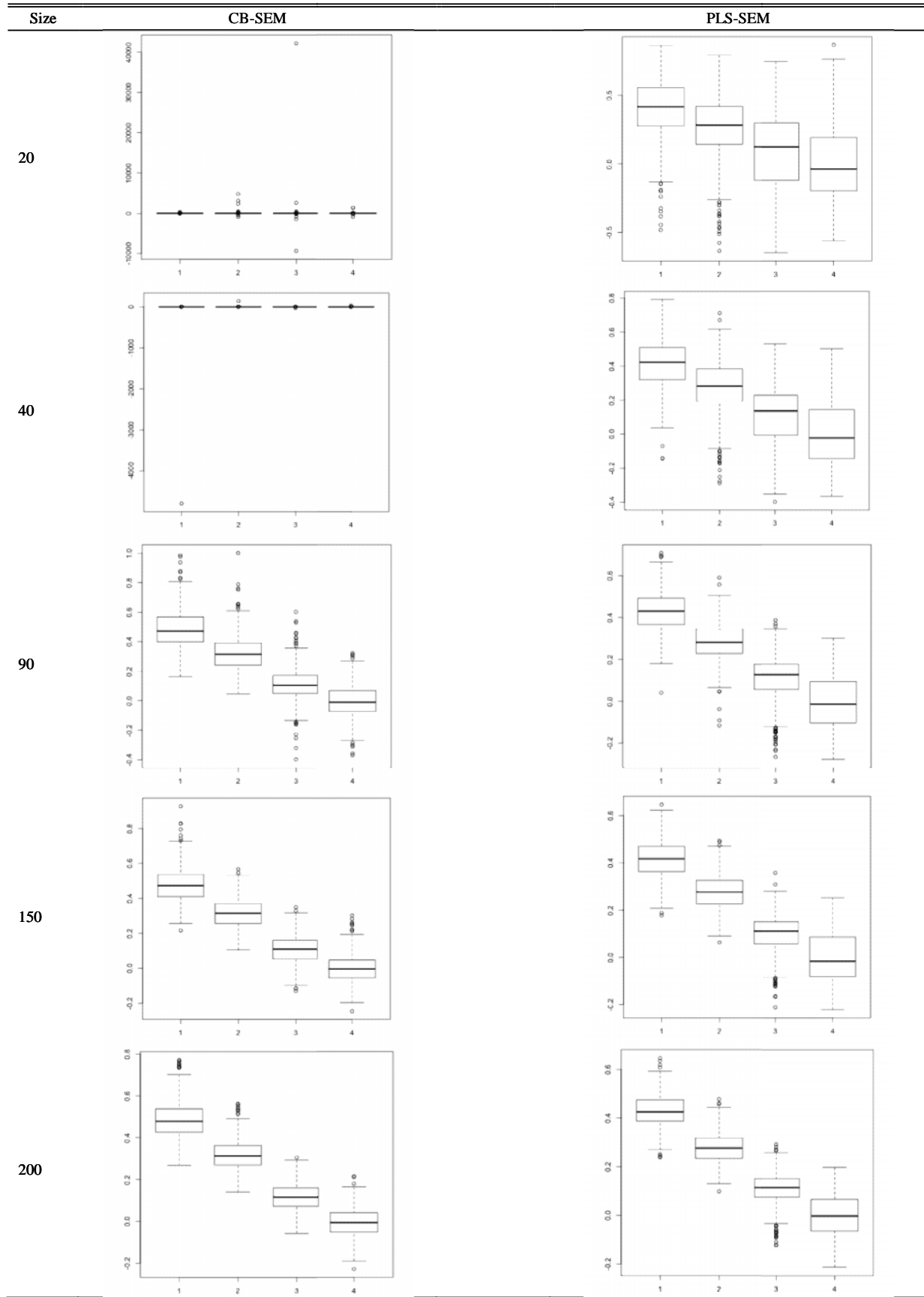

TABLE II
 BOX-PLOTS FOR CB-SEM AND PLS-SEM FOR NON-NORMAL DISTRIBUTION



IV. DISCUSSION OF SIMULATION RESULTS

This section reports the simulation results and analysis of the performance of the standardized path estimates for CB-SEM and PLS-SEM under normal and non-normal conditions. Graphical box-plots of the path estimates for various sample sizes for the normal and non-normal were presented for comparison purposes.

A. Effect of Normality on CB-SEM and PLS-SEM

Table I displays the box-plots of the standardized path estimates for CB-SEM and PLS-SEM for sample sizes of 20, 40, 90, 150 and 200. From the boxplots, the medians for the four standardized path estimates using CB-SEM were centered at 0 for $n = 20$.

However, PLS-SEM showed an added advantage over CB-SEM as it was observed that the median for the four path estimates (Gammas) approached the true values.

Turning to $n = 40$, the medians of the path estimates for both CB-SEM and PLS-SEM approached the true values of the parameter. The medians were getting close to the theoretical path estimates. Then, for $n = 90$ and 150, some similarities became apparent for CB-SEM and PLS-SEM. The median path estimates for both CB-SEM and PLS-SEM were noted to be close to the true parameter values. Similarly at $n = 150$, both CB-SEM and PLS-SEM estimates converged to the true path estimates. Finally, for large sample size of 200, the path estimates were all very close to the true values for both CB-SEM and PLS-SEM. However, a larger variability was observed for PLS-SEM path estimates.

B. Effect of Non-Normality on CB-SEM and PLS-SEM

Table II displays the box-plots for CB-SEM and PLS-SEM under nonnormal conditions. At the smallest sample size of $n = 20$, CB-SEM could not estimate the path values (Gamma 1 to 4). The median for the CB-SEM estimates were centered at zero. On the other hand, for $n = 20$, the four path estimates for PLS-SEM are close to the true parameter values. Similarly, at $n = 40$, the median of CB-SEM estimates are close to zero. Meanwhile, at $n = 40$, PLS-SEM could estimate the path estimates well. For $n = 90$, the medians of the CB-SEM estimates starts to approach the true parameter values. Results show that PLS-SEM was consistent in its ability to estimate path coefficients for all the different sample sizes. At a bigger sample size ($n = 150$ and 200), CB-SEM estimates have lower variability and the path estimates are also closer to the true values than PLS-SEM.

To investigate at which sample size CB-SEM and PLS-SEM estimates converge to the true values, the mean path estimate and 95% confidence interval for the mean was obtained. For brevity, only the means and confidence intervals for Gamma 1 (true value = 0.48) are shown in Table III. Confidence intervals are normally affected by the sample size; small sample size usually has a wider confidence interval, thus is less precise. According to the results in Table III, the median for CB-SEM estimates for Gamma1 for a sample size of 40 was centered at zero. However, PLS-SEM was able to estimate the path with mean value 0.528 and 95% confidence

interval (0.382, 0473). At $n = 45$, the mean CB-SEM estimate was 0.511 with a wide 95% confidence interval (0.439, 0.583).

TABLE III
 MEAN AND CONFIDENCE INTERVALS FOR NON-NORMAL DISTRIBUTION

Sample size (n)	Mean (95% Confidence Interval) for Gamma 1 (0.48)	
	CB-SEM	PLS-SEM
20	0.851 (-5.68, 7.39)	0.404 (0.309, 0.499)
25	11.72 (-83.7, 107.2)	0.417 (0.342, 0.492)
30	-135.3 (-1235, 965)	0.417 (0.357, 0.477)
35	0.519 (0.414, 0.623)	0.429 (0.375, 0.484)
40	0.447 (-0.022, 0.916)	0.428 (0.382, 0.473)
45	0.511 (0.439, 0.583)	0.418 (0.378, 0.458)
50	0.482 (0.424, 0.540)	0.431 (0.395, 0.467)
55	0.488 (0.437, 0.538)	0.416 (0.381, 0.449)
60	0.502 (0.457, 0.547)	0.432 (0.402, 0.461)
65	0.494 (0.453, 0.537)	0.418 (0.389, 0.446)
70	0.491 (0.450, 0.533)	0.421 (0.396, 0.447)
75	0.487 (0.452, 0.522)	0.429 (0.406, 0.453)
80	0.498 (0.446, 0.529)	0.421 (0.398, 0.443)
85	0.496 (0.462, 0.529)	0.414 (0.393, 0.437)
90	0.4906 (0.461, 0.520)	0.426 (0.405, 0.447)
95	0.489 (0.460, 0.518)	0.418 (0.399, 0.436)
100	0.490 (0.463, 0.516)	0.417 (0.398, 0.435)

Results show that under non-normal conditions, PLS-SEM could estimate the path but the values were far from the true parameter values. However, PLS-SEM estimates have smaller 95% confidence intervals for all sample sizes. Moreover, at a sample size of 60, both CB-SEM and PLS-SEM estimates are nearing the true parameter value but with CB-SEM having a slight advantage with men closer to the true value and smaller confidence interval. Thus, under non-normality conditions, the PLS-SEM estimates are less precise. CB-SEM is seen to perform well at sample size 50 and above under non-normal conditions.

V. CONCLUSION

This study compared CB-SEM and PLS-SEM when the distribution of observed variables is normal and nonnormal. Under normal distribution, CB-SEM failed to estimate correctly the path estimates for small sample sizes. PLS-SEM seemed to have a slight advantage over CB-SEM with the ability to report medians nearing the true values for small sizes. This is consistent with the findings by [13]. However, for larger samples both CB-SEM and PLS-SEM have estimates close to the theoretical values but the CB-SEM estimates are more consistent with lower variability. For Non-normal distribution, this study confirmed that CB-SEM clearly does not work for small sample size. For sample size larger than 50, CB-SEM produces more accurate estimates than PLS-SEM.

Although, it has been reported that PLS-SEM works well when distributional assumptions such as normality is not met, this study found that PLS-SEM path estimates are less precise than CB-SEM under both normal and non-normal conditions when sample size is sufficient. It is recommended that the choice between covariance (CB-SEM) and variance based

(PLS-SEM) depends on the research goal. CB-SEM is more appropriate for theory testing or confirmation of theory while PLS-SEM will be useful if the objective is for prediction of the endogenous variables. Further work is in progress to investigate a robust approach to handling outliers for CB-SEM and PLS-SEM

APPENDIX

The sample codes for PLS-SEM simulation using R are as follows:

```
set.seed(12345)
for (i in 1:500)
{
  data1 <- data.f(20)
  ex <- names(data1)
  Ex1m <- paste("KSI", c(rep(1:4, each=3)), sep="")
  Endo <- rep ("Eta1", each=3)
  ex1=c(Ex1m, Endo)
  Exmm <- cbind(source = ex1, target = ex)

  ## STRUCTURAL MODEL
  ext <- rep ("Eta1", each=4)
  Ex1mto <- paste("KSI", c(rep(1:4)), sep="")
  Ex1sm <- cbind(source = Ex1mto, target = ext)
  EX1 <- plsm(data = data1, strucmod = Ex1sm,
  measuremod = Exmm)
  goodhue <- sempls(model = EX1, data = data1,
  wscheme = "centroid", maxit = 500)
  beta[i, 1:4]<-pathCoeff(goodhue)[1:4, 5]
}
```

ACKNOWLEDGMENT

The authors would like to thank Professor Dale Goodhue, University of Georgia for his permission to use his theoretical model and the reviewers for their comments and suggestions.

REFERENCES

- [1] J. Henseler, "On the convergence of the partial least squares path modeling algorithm," *Computational Statistics*, vol. 25, no. 1, pp. 107–120, Aug. 2009.
- [2] H. Baumgartner and C. Homburg, "Applications of structural equation modeling in marketing and consumer research: A review," *International Journal of Research in Marketing*, vol. 13, no. 2, pp. 139–161, Apr. 1996.
- [3] L. Williams, J. Edwards, and R. Vandenberg, "Recent Advances in Causal Modeling Methods for Organizational and Management Research," *Journal of Management*, vol. 29, no. 6, pp. 903–936, Dec. 2003.
- [4] R. C. MacCallum and J. T. Austin, "Applications of Structural Equation Modeling in Psychological Research," *Annual Review of Psychology*, vol. 51, pp. 201–226, 2000.
- [5] K. Jöreskog, "Some contributions to Maximum Likelihood Factor Analysis," *Psychometrika*, vol. 32, no. 4, pp. 443–482, 1986.
- [6] J. F. Hair, W. C. Black, B. J. Babin, and R. E. Anderson, *Multivariate Data Analysis*, 7th ed. New York: Prentice Hall, 2009, pp. 1–816.
- [7] M. Haenlein and A. M. Kaplan, "A Beginner's Guide to Partial Least Squares Analysis," *Understanding Statistics*, vol. 3, no. 4, pp. 283–297, Nov. 2004.
- [8] E. E. Rigdon, C. M. Ringle, and M. Sarstedt, "Structural modeling of heterogeneous data with partial least squares," *Review of Marketing Research*, vol. 7, pp. 257–298, 2010.
- [9] D. W. Barclay, C. A. Higgins, and R. Thompson, "The partial least squares (PLS) approach to causal modeling: personal computer adoption and use as an illustration," *Technology Studies*, vol. 2, pp. 285–323, 1995.
- [10] W. W. Chin and B. L. Marcolin, "A Partial Least Squares latent variable modeling approach for measuring interaction effects: Results from a Monte Carlo Simulation study and an Electronic-Mail Emotion/Adoption study," *Information Systems Research*, vol. 14, no. 2, pp. 189–217, 2003.
- [11] D. Gefen, D. Straub, and M.-C. Boudreau, "Structural Equation Modeling and Regression: Guidelines for research Practice," *Communications of the Association for Information Systems*, vol. 4, no. 7, pp. 1–78, 2000.
- [12] W. W. Chin, "Commentary Issues and Opinion on Structural Equation Modeling," *MIS Quarterly*, vol. 22, no. 1, pp. 7–11, 1998.
- [13] W. W. Chin, and P. R. Newsted, *Structural equation modelling analysis with small samples using partial least squares*. In R. H. Hoyle (Ed.), *Statistical strategies for small sample research*. Thousand Oaks: SAGE Publications, 1999.
- [14] Jöreskog and Sorbom, *LISREL 8 User's Reference Guide*. Chicago, Scientific Software, 1996.
- [15] J. L. Arbuckle, *Amos 18.0 User's Guide*. Chicago: SPSS, 1995.
- [16] P. Bentler, *EQS: Structural equations program manual*. BMDP Statistical Software Inc., Los Angeles, CA, 1989.
- [17] C. M. Ringle, S. Wende, and A. Will, *SmartPLS 2.0 (beta)*. Hamburg, Germany, 2005.
- [18] M. Haenlein and A. M. Kaplan, "A Beginner's Guide to Partial Least Squares Analysis," *Understanding Statistics*, vol. 3, no. 4, pp. 283–297, Nov. 2004.
- [19] P. M. Bentler, and C. P. Chou, "Practical issues in structural modeling," *Sociological Methods & Research*, Vol. 16, pp. 78–117, 1987.
- [20] D. L. Goodhue, W. Lewis, and R. Thompson, "Does PLS have Advantages for Small Sample Size or Non-Normal Data?," *MIS Quarterly*, vol. 36, no. 3, pp. 1–21, 2012.
- [21] C. M. Ringle, Sarstedt, and D. W. Straub, "A critical look at the use of PLS-SEM in MIS quarterly," *MIS Quarterly*, Vol. 36, no. 1, pp. 3–14, 2012.
- [22] W. Reinartz, M. Haenlein, and J. Henseler, "An empirical comparison of the efficacy of covariance-based and variance-based SEM," *International Journal of Research in Marketing*, vol. 26, no. 4, pp. 332–344, Dec. 2009.
- [23] J. F. Hair, C. M. Ringle, and M. Sarstedt, "PLS-SEM: Indeed a Silver Bullet," *The Journal of Marketing Theory and Practice*, vol. 19, no. 2, pp. 139–152, Apr. 2011.
- [24] H. Wold, "Path models with latent variables: The NIPALS approach", in H. M. Blalock, A. Aganbegian, F. M. Borodkin, R. Boudon, & V. Capecchi (Eds.), *Quantitative sociology: International perspectives on mathematical and statistical modeling* New York: Academic, 1975, pp. 307–357.
- [25] J. Henseler, "On the convergence of the partial least squares path modeling algorithm," *Computational Statistics*, vol. 25, no. 1, pp. 107–120, Aug. 2009.
- [26] T. Dijkstra, "Some comments on maximum likelihood and partial least squares methods," *Journal of Econometrics*, Vol. 22, no. 1, pp. 67–90, 1983.
- [27] K. G. Jöreskog and D. Sorbom, "Recent developments in structural equation modeling," *Journal of Marketing Research*, vol. 19, pp. 404–416, 1982.
- [28] K. G. Jöreskog, and D. Sorbom, *LISREL VI: Analysis of linear structural relationships by the method of maximum likelihood*, Chicago: National Educational Resources, 1984.
- [29] J. J. Hoogland and A. Boomsma, "Robustness Studies in Covariance Structure Modeling: An Overview and a Meta-Analysis," *Sociological Methods & Research*, vol. 26, no. 3, pp. 329–367, Feb. 1998.
- [30] J. C. Anderson and D. W. Gerbing, "Structural equation modeling in practice: A review and recommended two-step approach" *Psychological Bulletin*, vol. 103, no. 3, pp. 411–423, 1988.
- [31] H. Wold, "Soft Modeling: Intermediate between Traditional Model Building and Data Analysis," *Mathematical Statistics*, vol. 6, pp. 333–346, 1882.
- [32] Y. Rosseel, "lavaan": An R Package for Structural Equation," *Journal of Statistical Software*, vol. 48, no. 2, pp. 1–36, 2012.
- [33] A. Monecke and F. Leisch, "semPLS": Structural Equation Modeling Using Partial Least Squares," *Journal of Statistical Software*, vol. 48, no. 3, pp. 1–32, 2012.