

Performance Evaluation and Cost Analysis of Standby Systems

M. A. Hajeesh

Abstract—Pumping systems are an integral part of water desalination plants, their effective functioning is vital for the operation of a plant. In this research work, the reliability and availability of pressurized pumps in a reverse osmosis desalination plant are studied with the objective of finding configurations that provides optimal performance. Six configurations of a series system with different number of warm and cold standby components were examined. Closed form expressions for the mean time to failure (MTTF) and the long run availability are derived and compared under the assumption that the time between failures and repair times of the primary and standby components are exponentially distributed. Moreover, a cost/ benefit analysis is conducted in order to identify a configuration with the best performance and least cost. It is concluded that configurations with cold standby components are preferable especially when the pumps are of the size.

Keywords—Availability, Cost/ benefit, Mean time to failure, Pumps.

I. INTRODUCTION

THE literature is full of articles related to the performance of standby systems. The reliability and availability of five different series system configurations were compared [1]. The performance of series systems with cold and warm standby components were examined [2]. Meanwhile, the reliability of a two unit standby system with single repair was discussed [3]. In this work, it assumed that the operative and standby units to be interchanged at random epochs. The reliability of three two unit standby systems, which were further connected to two sub-units in series were derived [4]. A comprehensive analysis of a three unit warm standby was discussed [5]. The availability and reliability functions using these imbedded renewal points were derived.

Seven standby system configurations consisting of combinations of two different types of non-repairable operating parts were studied [6]. Mean times between failures were used to compare the different configurations. The reliability and sensitivity analysis of M primary units with W standby units was examined [7]; Laplace transform was used to find the reliability of the system, under exponentially distributed time between failures and repair times.

A reliability and mean time to failure for a two-state complex system consisting of two sub-systems A and B arranged in series, using the concept of hardware and human failures were presented [8]. Laplace transforms were used to measure the system effectiveness. The performance of a

M. A. Hajeesh is with the Kuwait Institute for Scientific Research, Techno-Economics Division, P.O. Box 24885; Safat-13109, Kuwait. (phone:965-2498-6593; fax: 954-2948-9499; e-mail: mhajeesh@kisir.edu.kw).

deteriorated system was examined, inspection was carried out at each deteriorated stage, and to evaluate the performance of the system at each action, an analytical expression for the asymptotic availability was derived [9].

II. SYSTEM DESCRIPTION

Commercially available desalination techniques are categorized into two types, i.e., distillation and membrane-based technologies. The distillation processes transform water into vapor then condense it into a liquid state. This process requires power in the form of thermal and electrical energy. Commercially available desalination techniques include multistage flash (MSF), multi-effect desalination (MED), and vapor compression (VC). In the process reverse osmosis (RO), feed-water is first pretreated to remove suspended solids. Pretreatment can vary from cartridge filter type, multimedia filter, and to micro/ ultra filtration in some cases. The feed is chemically pretreated and pH adjusted, depending on the type of membrane used. The pretreated feed is then pressurized to the needed value depending on its salt content and passed through the RO membrane. Brine is the byproduct of the process, and it has a higher salt concentration than the brine produced by the thermal processes. The process can achieve up to 40% recovery from seawater and 75% from brackish water application (Fig. 1).

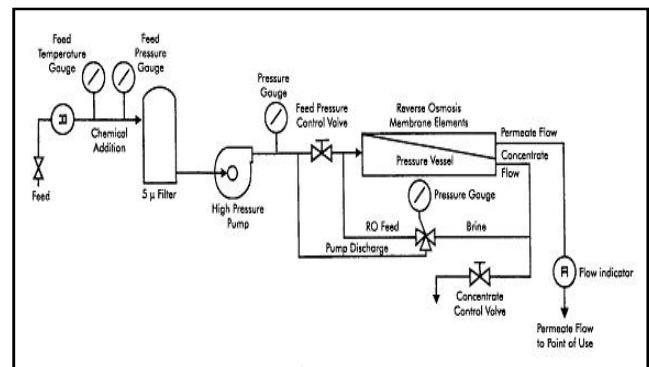

Fig. 1 Detailed representation of an RO plant

In RO process for occurrence of reverse osmosis, a very high pressure to be applied on the pretreated saline water. Pressurization is accomplished by suitable type-high pressure head pumps. These pumps are called high pressure pumps; the net driving head depends on the osmotic pressure on the saline solution. The pressure pumps are generally energized by electrical energy. There two main types of pressurized pumps are used to pump the water depending on the pressure head, an

80 bar pressure and the 40 bar pressure pumps. The objective is used combination of pumps in order to maximize to maximize both the reliability and the availability of the system at minimum cost. Six configurations are suggested, configuration I with one three 80 bar pumps, one in operation, one in warm standby, and one in cold standby. The second option, configuration II consists of one 80 bar pump in operation, one 80 bar pump in warm standby, and two 40 bar pumps in cold standby, while the third configuration has one 80 bar pump in operation, two 40 bar pumps in warm standby, and two 40 bar pumps in cold standby. Configurations VI, V, and VI are composed of six 40 bar pumps. Configuration IV has two 40 bar pumps in operation, two 40 bar pumps in warm standby, and two 40 bar pumps in cold standby. Configuration V has two 40 bar pumps in operation, one 40 bar pump in warm standby, and three 40 bar pumps in cold standby, configuration VI has two 40 bar pumps in operation, three 40 bar pumps in warm and one 40 bar pump in cold standby.

The objective is to find the mean time to failure (MTTF), availability, and the cost of the different configurations. The main assumptions are that one pump fails at a time, one failed pump is repaired at a time, one repairman, the times to pumps in operation and warm are negligible, and the time between failure and repair times are exponentially distributed. For all configurations, the failure rate of the operating pump, the failure rate of the warm standby pump, and the repair rate of the failed pump are designated by λ , β , and μ , respectively.

A. Reliability Analysis

1. Configuration I

Let $P_n(t)$ equals that probability that n components within a system have failed at time t , ($t \geq 0$). If $P(t)$ denotes that probability vector at time t , then the initial conditions are:

$$P(0) = [p_0(0), p_1(0), p_2(0), p_3(0)] = [1, 0, 0, 0] \quad (1)$$

If we let $P_n(t) = P_n$, then the following differential equations are obtained:

$$\begin{aligned} \frac{dp_0}{dt} &= -(\lambda + \beta)p_1 + \mu p_2 \\ \frac{dp_1}{dt} &= (\lambda + \beta)p_1 - (\lambda + \beta + \mu)p_2 + \mu p_3 \\ \frac{dp_2}{dt} &= (\lambda + \beta)p_2 - (\lambda + \beta + \mu)p_3 + \mu p_4 \\ \frac{dp_3}{dt} &= \lambda p_3 \end{aligned} \quad (2)$$

The above set of equation can be expressed as:

$$\dot{P} = QP \quad (3)$$

$$Q = \begin{bmatrix} -(\lambda + \beta) & \mu & 0 & 0 \\ (\lambda + \beta) & -(\lambda + \beta + \mu) & \mu & 0 \\ 0 & (\lambda + \beta) & -(\lambda + \mu) & 0 \\ 0 & 0 & \lambda & 0 \end{bmatrix}$$

In calculating the *MTTF*, we take the transpose of the above matrix, and delete the absorbing (failed) state. The new matrix is designated as M , the expected time to reach and an absorbing state is calculated using:

$$E[T_{p(0)} \rightarrow p(\text{absorbing})] = P(0)(-M^{-1}) \begin{pmatrix} 1 \\ 1 \\ 1 \\ 1 \end{pmatrix} \quad (4)$$

where

$$M = \begin{bmatrix} -(\lambda + \beta) & (\lambda + \beta) & 0 \\ \mu & -(\lambda + \beta + \mu) & (\lambda + \beta) \\ 0 & \mu & -(\lambda + \mu) \end{bmatrix}$$

This method is successful since:

$$E[T_{p(0)} \rightarrow p(\text{absorbing})] = P(0) \int_0^{\infty} e^{Mt} dt \quad (5)$$

and

$$\int_0^{\infty} e^{Mt} dt = -M^{-1} \quad (6)$$

For the above configuration, the explicit expression for *MTTF* is:

$$E[T_{p(0)} \rightarrow p(\text{absorbing})] = \text{MTTF} \quad (7)$$

which can be explicitly expressed as

$$\text{MTTF} = \frac{(3\lambda + \beta + \mu)}{\lambda(\lambda + \beta)} + \frac{\mu(\lambda + \mu)}{\lambda(\lambda + \beta)^2} \quad (8)$$

2. Configuration II

$$\text{MTTF} = \frac{(3\lambda + \beta)}{2\lambda(\lambda + \beta)} + \frac{(2\lambda + \mu)}{2\lambda(\lambda + 2\beta)} + \frac{\mu(2\lambda + \mu)}{2\lambda(\lambda + \beta)(\lambda + 2\beta)} \quad (9)$$

3. Configuration III

$$\text{MTTF} = \left[\frac{3\lambda + 2\beta}{2\lambda(\lambda + 2\beta)} + \frac{4\lambda + 3\beta}{2(\lambda + \beta)(2\lambda + \beta)} + \frac{2\mu}{2\lambda(\lambda + 2\beta)} + \frac{\mu^2(4\lambda + 4\beta + \mu)}{4\lambda(\lambda + \beta)(\lambda + 2\beta)(2\lambda + \beta)} \right] \quad (10)$$

4. Configuration IV

$$MTTF = \left[\frac{10\lambda^2 + 8\lambda\beta + \beta^2}{2\lambda(\lambda + \beta)(2\lambda + \beta)} + \frac{\mu(3\lambda + \beta)}{2\lambda(\lambda + \beta)^2} + \frac{\mu^2(3\lambda + 2\beta)}{8\lambda(\lambda + \beta)^3} + \frac{\mu^3(4\lambda + 2\beta + \mu)}{16\lambda(\lambda + \beta)^3(2\lambda + \beta)} \right] \quad (11)$$

5. Configuration V

$$MTTF = \left[\frac{10\lambda + \beta}{2\lambda(2\lambda + \beta)} + \frac{\mu(8\lambda + \beta)}{2\lambda(2\lambda + \beta)^2} + \frac{\mu^2(6\lambda + \beta)}{2\lambda(2\lambda + \beta)^3} + \frac{\mu^3(4\lambda + \beta + \mu)}{2\lambda(2\lambda + \beta)^4} \right] \quad (12)$$

6. Configuration VI

$$MTTF = \left[\frac{\frac{3(2\lambda + \beta)}{2\lambda(2\lambda + 3\beta)} + \frac{(4\lambda + 3\beta)}{2(2\lambda + \beta)(\lambda + \beta)} + \mu \left[\frac{(2\lambda + 2\beta)^3 + (2\lambda + \beta)^2 + \lambda\beta(6\lambda + 5\beta)}{2\lambda(2\lambda + 3\beta)^2(2\lambda + \beta)(\lambda + \beta)} \right]}{\frac{\mu^2 \left[9(\lambda + \beta)^2 + \lambda(3\lambda + 2\beta) \right]}{4\lambda(2\lambda + 3\beta)^2(2\lambda + \beta)(\lambda + \beta)} + \frac{\mu^3(4\lambda + 3\beta + \mu)}{4\lambda(2\lambda + 3\beta)^2(\lambda + \beta)(2\lambda + \beta)}} \right] \quad (13)$$

B. Availability Analysis

1. Configuration I

The initial conditions are the same as those of the reliability, these are:

$$P(0) = [p_0(0), p_1(0), p_2(0), p_3(0)] = [1, 0, 0, 0] \quad (14)$$

The differential equations for this system can be written as:

$$\begin{bmatrix} \dot{p}_0 \\ \dot{p}_1 \\ \dot{p}_2 \\ \dot{p}_3 \end{bmatrix} = \begin{bmatrix} -(\lambda + \beta) & \mu & 0 & 0 \\ (\lambda + \beta) & -(\lambda + \beta + \mu) & \mu & 0 \\ 0 & (\lambda + \beta) & -(\lambda + \mu) & \mu \\ 0 & 0 & \lambda & -\mu \end{bmatrix} \begin{bmatrix} p_0 \\ p_1 \\ p_2 \\ p_3 \end{bmatrix} \quad (15)$$

In order to derive the state availability, the derivatives of the state probabilities are equated to zero:

$$QP(\infty) = 0$$

$$\begin{bmatrix} -(\lambda + \beta) & \mu & 0 & 0 \\ (\lambda + \beta) & -(\lambda + \beta + \mu) & \mu & 0 \\ 0 & (\lambda + \beta) & -(\lambda + \mu) & \mu \\ 0 & 0 & \lambda & -\mu \end{bmatrix} \begin{bmatrix} p_0 \\ p_1 \\ p_2 \\ p_3 \end{bmatrix} = \begin{bmatrix} 0 \\ 0 \\ 0 \\ 0 \end{bmatrix} \quad (16)$$

Using the following normalization condition:

$$\sum_{j=0}^4 p_j(\infty) = 1 \quad (17)$$

Substituting the relation in (49) in any one of the redundant rows of (50) yields:

$$\begin{bmatrix} -(\lambda + \beta) & \mu & 0 & 0 \\ (\lambda + \beta) & -(\lambda + \beta + \mu) & \mu & 0 \\ 0 & (\lambda + \beta) & -(\lambda + \mu) & \mu \\ 1 & 1 & 1 & 1 \end{bmatrix} \begin{bmatrix} p_0 \\ p_1 \\ p_2 \\ p_3 \end{bmatrix} = \begin{bmatrix} 0 \\ 0 \\ 0 \\ 1 \end{bmatrix} \quad (18)$$

Solving the above set of equations for provides the steady state probabilities, summing the probabilities of the operational states gives an expression for the steady state of the system which as follows:

$$A_s = \frac{\mu [(\lambda + \beta)^2 + \mu((\lambda + \beta + \mu))]}{\lambda(\lambda + \beta)^2 + \mu [(\lambda + \beta)^2 + \mu((\lambda + \beta + \mu))]} \quad (19)$$

2. Configuration II

$$A_s = \frac{(\lambda + \beta)(5\lambda + 2\beta) + \beta(2\lambda + \mu) + \mu(3\lambda + \mu)}{2\lambda(\lambda + \beta)(\lambda + 2\beta) + \mu [(\lambda + \beta)(\lambda + 2\beta) + \mu(\lambda + \beta + \mu)]} \quad (20)$$

3. Configuration III

$$A_s = \frac{\mu \left[\frac{2(\lambda + \beta)(\lambda + 2\beta)(2\lambda + \beta)}{+ \mu(\lambda + 2\beta)(2\lambda + 3\beta + \mu) + \mu^3} \right]}{\left\{ \begin{array}{l} 4\lambda(\lambda + \beta)(\lambda + 2\beta)(2\lambda + \beta) \\ + \mu \left[\frac{2(\lambda + \beta)(\lambda + 2\beta)(2\lambda + \beta)}{+ \mu(\lambda + 2\beta)(2\lambda + 3\beta + \mu) + \mu^3} \right] \end{array} \right\}} \quad (21)$$

4. Configuration IV

$$A_s = \frac{\mu \left[\frac{2(\lambda + \beta)(\lambda + 2\beta)(2\lambda + \beta)}{+ \mu(\lambda + 2\beta)(2\lambda + 3\beta + \mu) + \mu^3} \right]}{\left\{ 4\lambda(\lambda + \beta)(\lambda + 2\beta)(2\lambda + \beta) + \mu \left[\frac{2(\lambda + \beta)(\lambda + 2\beta)(2\lambda + \beta)}{+ \mu(\lambda + 2\beta)(2\lambda + 3\beta + \mu) + \mu^3} \right] \right\}} \quad (22)$$

5. Configuration V

$$A = \frac{\mu \left[\frac{(2\lambda + \beta)^4 + \mu(2\lambda + \beta)^2(2\lambda + \beta + \mu)}{+ \mu^3(2\lambda + \beta + \mu)} \right]}{\left\{ 2\lambda(2\lambda + \beta)^4 + \mu \left[\frac{(2\lambda + \beta)^4 + \mu(2\lambda + \beta)^2(2\lambda + \beta + \mu)}{+ \mu^3(2\lambda + \beta + \mu)} \right] \right\}} \quad (23)$$

6. Configuration VI

$$A = \frac{\mu \left[\frac{2(\lambda + \beta)(2\lambda + \beta)(2\lambda + 3\beta)^2}{+ \mu(2\lambda + 3\beta)^2(2\lambda + 2\beta + \mu) + \mu^3(2\lambda + 3\beta + \mu)} \right]}{\left\{ \begin{array}{l} 4\lambda(\lambda + \beta)(2\lambda + \beta)(2\lambda + 3\beta)^2 \\ + \mu \left[\frac{2(\lambda + \beta)(2\lambda + \beta)(2\lambda + 3\beta)^2}{+ \mu(2\lambda + 3\beta)^2(2\lambda + 2\beta + \mu)} \right] \right\}} \quad (24)$$

III. COST/BENEFIT ANALYSIS

We assume that cost is related to the size of the component (pump) whether in operation, warm or cold standby. The cost of the different pump sizes and positions are as given in Table I, and the cost of the various configurations in Table II. We utilize the cost benefit ratio for ranking the different configuration as follows:

C_i = cost of configuration i , $i=1,2,\dots,6$.
 B_i = benefit of configuration i , $MTTF_i$ (system reliability) of configuration i , or A_s the steady state availability of configuration i , $i=1,2,3,4,5,6$.

TABLE I
 PURCHASE COST OF THE DIFFERENT PUMPS BASED ON SIZE AND STATUS

Component	Cost (\$)
Primary 80 Bar	800,000
Warm Standby 80 Bar	600,000
Cold standby 80 Bar	500,000
Primary 40 Bar	400,000
Warm Standby 40 Bar	300,000
Cold Standby 40 Bar	200,000

TABLE II
 CAPITAL COST OF THE VARIOUS PUMPS CONFIGURATIONS

Configuration	Cost (\$)
I	1,900,000
II	1,800,000
III	1,800,000
IV	1,800,000
V	1,700,000
VI	1,900,000

IV. EXAMPLES

The objective here is to compare the different costs and benefits of the different configurations. The benefit associated for each configuration is equivalent to the $MTTF$ and steady state availability of that configuration. Table III provides ranking of the different configuration based on cost/ $MTTF$ for various ratios of the repair rate (μ) to failure rate (λ) for $\lambda = 0.5$, the failure rate of the warm standby components ($\beta = 0.03$), while Table IV provides the ranking of the different configurations based on cost/ steady availability with the same parameters as before.

TABLE III
 RANKING OF THE VARIOUS CONFIGURATION FOR COST/MTTF AGAINST DIFFERENT (μ/λ) RATIOS

Configuration	(μ/λ)					
	1	2	3	4	5-6	≥ 7
I	2	2	2	3	4	4
II	4	5	6	6	6	6
III	5	4	5	5	5	5
IV	3	3	3	2	2	2
V	1	1	1	1	1	1
VI	6	6	4	4	3	3

TABLE IV
 RANKING OF THE VARIOUS CONFIGURATION FOR COST/AVAILABILITY AGAINST DIFFERENT (μ/λ) RATIOS

Configuration	(μ/λ)								
	1	2	3	4	5	6	7	8-9	≥ 10
I	1	1	1	2	2	2	3	2	2
II	2	2	3	3	5	5	3	5	2
III	5	4	5	3	4	2	3	2	2
IV	3	6	4	5	2	2	2	2	2
V	4	3	1	1	1	1	1	1	1
VI	6	5	6	6	6	6	6	6	6

As can be observed from Table III when comparing the different configuration based on Cost/ $MTTF$ it is apparent that configuration V is the most favorable, Configurations II, and

IV comes next, followed by configuration III, and VI. Configuration II is the least favorable. When comparing the different configurations based on the cost/availability, again configuration V is the best with the least cost, configuration I comes second, then configurations IV, III, and II, respectively.

V. CONCLUSIONS

The analysis of the different configurations in terms of cost and performance showed the most cost/beneficial configuration is the most favorable. In this configuration, two pumps of size 40 bars are in operation, one in warm standby, and three in cold standby.

It is concluded that configurations with highest number of components in cold standby has superior performance when compared to the other. Moreover, if we have to choice between different sizes of components, we should select the one with size with higher capacity. In addition, it was shown that it is more favorable to have components of same capacity in all positions, in operation, cold standby, or warm standby.

REFERENCES

- [1] C. Galikowsky, B.D. Sivazlian and P. Chaovaitwongse, "Optimal redundancies for reliability and availability of series systems," *Microelectronics Reliability*, Vol. 36, pp.1536-1546, October 1996.
- [2] K.H. Wang and W.L. Pearn, "Cost benefits analysis of series systems with standby components," *Mathematical Methods of Operations Research*, Vol.58, pp. 247-258, November 2003
- [3] K.El-Said and M.S. El-Sherbeny, "Profit analysis of a two unit cold standby system with preventive maintenance and random change of units," *Journal of Mathematics and Statistics*, Vol. 1, pp.71-77, January 2005.
- [4] R. Gupta, S.K. Mittal, and C.M. Batra, "Stochastic analysis of a compound redundant system involving human failure," *Journal of Mathematics and Statistics*, Vol. 2, pp. 407- 413, September 2006.
- [5] S. Srinivasan and R. Subramanian, "Reliability analysis of a three warm standby redundant system with repair," *Annals of Operations Research*, Vol. 143, pp. 227-235, January 2006
- [6] R. Hamilton and I. Bazovsky, "Simplified Markov technique for some stand-by redundant systems," *Quality and Reliability Engineering International*, Vol. 2, pp. 233-240 January, 2007
- [7] J.B. Ke, W.C. Lee and J.C. Ke, "Reliability-based measure for a system with standbys subjected to switching failures," *Engineering Computations*, Vol. 25, pp. 694-706, 2008
- [8] G.S.Mokaddis, M.S. El-Sherbeny and E. Al-Esayeh, "Stochastic behavior of redundant complex system with two types of failure," *Journal of Mathematics and Statistics*, Vol.5, pp. 112-117, June 2009
- [9] M. Hajeer and M.S. Moustafa, "Availability of deteriorating system under inspection and maintenance strategies," *International Journal of Reliability and Safety*, Vol. 3, pp. 384-296, October 2009.