

# Cluster Based Energy Efficient and Fault Tolerant n-Coverage in Wireless Sensor Network

D. Satish Kumar, N. Nagarajan

**Abstract**—Coverage conservation and extend the network lifetime are the primary issues in wireless sensor networks. Due to the large variety of applications, coverage is focus to a wide range of interpretations. The applications necessitate that each point in the area is observed by only one sensor while other applications may require that each point is enclosed by at least sensors ( $n > 1$ ) to achieve fault tolerance. Sensor scheduling activities in existing Transparent and non- Transparent relay modes (T-NT) Mobile Multi-Hop relay networks fails to guarantee area coverage with minimal energy consumption and fault tolerance. To overcome these issues, Cluster based Energy Competent n- coverage scheme called (CEC n-coverage scheme) to ensure the full coverage of a monitored area while saving energy. CEC n-coverage scheme uses a novel sensor scheduling scheme based on the n-density and the remaining energy of each sensor to determine the state of all the deployed sensors to be either active or sleep as well as the state durations. Hence, it is attractive to trigger a minimum number of sensors that are able to ensure coverage area and turn off some redundant sensors to save energy and therefore extend network lifetime. In addition, decide a smallest amount of active sensors based on the degree coverage required and its level. A variety of numerical parameters are computed using ns2 simulator on existing (T-NT) Mobile Multi-Hop relay networks and CEC n-coverage scheme. Simulation results showed that CEC n-coverage scheme in wireless sensor network provides better performance in terms of the energy efficiency, 6.61% reduced fault tolerant in terms of seconds and the percentage of active sensors to guarantee the area coverage compared to exiting algorithm.

**Keywords**—Wireless Sensor network, Mobile Multi-Hop relay networks, n-coverage, Cluster based Energy Competent, Transparent and non- Transparent relay modes, Fault Tolerant, sensor scheduling.

## I. INTRODUCTION

A wireless sensor network (WSN) consists of a large number of sensor nodes deploy over a geographical area for monitoring physical incident like temperature, humidity, vibrations, seismic events, and so on. These sensor nodes work together on a universal sensing task and deliver required data to one or more remote sinks. Classically, a sensor node is an insignificant device that includes three essential components: a sensing subsystem for data acquisition from the physical neighboring surroundings, a processing subsystem for restricted data processing and storage, and a wireless communication subsystem for data transmission. Sensor nodes

are usually powered by lightweight batteries, and replacing or recharging these batteries is often not practicable since sensor nodes may be deployed in an argumentative or unpractical environment.

Transparent mode contains the Relay Station (RS) do not forward framing information, and hence does not intensify the coverage area of the wireless access system. As a result, the foremost use case for transparent mode relays is to make possible capacity increases within the BS coverage area. This type of relay is of high complexity, and only activate in a centralized scheduling mode [1] and for topology up to two hops.

Non-transparent mode produces framing information or forward those offer by the BS depending on the scheduling approach (i.e., distributed or centralized). They support larger coverage areas and hence are mainly used to provide increased coverage. On the other hand, the transmission of the framing information result in high interference between neighboring RS hence, the capability improvement that achieved using relays [1].

Moreover, WSN should have a lifetime elongated sufficient to fulfill the application requirements. Thus, low power consumption becomes a critical factor to be considered, especially in the design of algorithms and network protocols at all layers of the network architecture. In WSNs, sensors are regularly deployed in great amount to examine an area; it results from that the emergence of points within the area monitored which are covered by several sensors. So, to save energy, it should be essential to program the sensor movement such that to permit unnecessary sensors to come in the sleep mode as often and for as long as possible.

Several works addressed the problem of active sensor selection, also known as sensor-scheduling, in WSN. However, at the most excellent of knowledge, work is the primary attempt that implies the location of a sensor represent by its n-density and its remaining energy to select the active sensors. Moreover, we tackled the problem of selecting a reduced set of active sensors among the deployed sensors so that these sensors ensure the full n-coverage of the monitored area where each position in the area is monitored by at least  $n$  ( $n \geq 1$ ) sensors. The good quality choice of this set is important because it could diminish energy consumption, and thus extend network lifetime.

The problem of sensor scheduling activities guarantees area coverage with lesser energy and fault free while maximizing network lifetime. For that, proposed a Cluster based Energy Competent n- coverage scheme called (CEC n-coverage scheme) to deal with the problem of preservation coverage and

D.Satish Kumar is with the Nehru Institute of Technology, Coimbatore, PIN 641105 India (phone: +919843723396; fax: 0422-2251147; e-mail: satishcoimbatore@yahoo.co.in).

Dr. N. Nagarajan, is with Coimbatore Institute of Engineering and technology, Coimbatore, Tamilnadu 641109 India. He is now with the Department of Computer Science and Engineering, CIET, Coimbatore, India (e-mail: swekalnag@gmail.com).

the problem of saving energy. CEC n-coverage scheme used clustering approach because it permits to save energy by avoiding frequent communication collisions and redundant messages in a sensor network since only the cluster heads that are responsible for transmitting the collected data to the remote sink, directly or via multi-hop transmission mode.

Moreover, CEC n-coverage scheme resolve whether each position on the monitor area of a wireless sensor network is covered by  $n$  ( $n \geq 1$ ) sensors for effective energy usage. It defines some terms and notations used by CEC n-coverage scheme. In addition, determining a smallest amount number of active sensors is based on the degree coverage required and its level. Moreover, when the n-coverage is less than the holes in the observed area (i.e.) points not enclosed in the examined area of WSN. The emergence of these holes may be due to failure of sensors or their disabling.

The paper is structured as follows. Sections II provide the related work. Section III describes the Cluster based Energy Competent n- coverage scheme with scheduling algorithm. Section IV demonstrates the ns2 simulator environment. Section V details the performance with resultant table and graph. Section VI provides conclusions about proposed work.

## II. LITERATURE REVIEW

Different from mobile base station or data mules, mobile relays do not convey data; instead, they shift to dissimilar locations and then stay behind stationary to forward data along the paths from the sources to the base station [2]. Holistic approach diminishes the total energy consumed by together mobility of relays and wireless broadcasting. To organize Relay Point (RP) in a grid pattern and to use the tree-based relaying network for dropping the cost of the RP and for reducing the control overhead incurred by the route setup from sinks to the GW. The optimal placement of RP becomes a level more complex problem if static sinks are vigorously additional or the route of mobile sinks cannot be recognized in advance [4].

The goal of convex hull algorithm is to optimize the number of sensors, low power consumption, to place nodes properly and settle on node placement to hold up a distributed sensor network in asymmetric area. As numerous areas in these ordinary methods which do not necessitate sensor placements have also been enclosed [12], the number of sensors in the preferred area is being increased and subsequently it leads to energy consumption upsurge.

An algorithm based on connected dominating set (CDS) and used it as a virtual backbone for network connectivity. Some nodes are advanced from separation to the backbone network, while others are connected under the tributaries of backbone network. If all the nodes are activating concurrently [10], it leads to redundancy and expenditure of resources in the network. The various multi-objective DPAPs can be distinct and tackle by problem-specific MOEA/Ds, similarly. Besides, the hybridization of MOEA/D with problem-specific local improvement techniques does not improving the performance of MOEA/D [11].

Transmission power between nodes directs a QoS metrics as multi objective problem and operates with any Medium Access control (MAC) protocol. It provided that it employs an acknowledgment (ACK) mechanism [5]. Localized Power Efficient Data Aggregation Protocols (L-PEDAP) are based on topologies, such as LMST and RNG, that approximate minimum spanning tree and competently computed using only position or distance information of one-hop neighbors [7]. The actual routing tree is constructing over these topologies and compared every topology and parent selection policy and concludes that the best among them.

Ant colony algorithms named DAACA for data aggregation consists of three phases namely initialization, packets broadcasting and operations on pheromones. In the transmission phase, each node estimates the outstanding energy and the quantity of pheromones of neighbor nodes to calculate the probabilities for vigorously selecting the next hop. After certain rounds of transmissions, the pheromones adjustments are performed, which take the compensation of both global and local merits for evaporating or depositing pheromones [3]. An account for link stability and for minimum drain rate energy consumption verifies the correctness of the bio goal optimization formulation [14]. LAER protocols succeed to the scalability of GPSR and E-GPSR, improving the performance in terms of node selection with higher link duration.

HiFAS fails in utilize energy harvesting in this network to grow longer the network lifetime with a factor of multiple of 2 which is truly very ambitious. Presented model provides the energy efficiency and fault tolerance when the sensor nodes are static but not in dynamic stage. Mobility is another issue that needs to be handled in clustering protocols as almost none of the present work provides clustering with dynamic deployment [6]. Formalize the difficulty by important a linear, varied integer mathematical programming model which include an integer of constraints and penalty components, aimed at intimately modeling the precise characteristics of the wireless environment. On-line estimators are not considered to calculate node positions, link costs, and traffic loads [13].

Fault Tolerant Trajectory Clustering (FTTC) technique for choosing the cluster heads in WSN algorithm choose the cluster heads based on traffic and rotates occasionally. It provides the first Fault Tolerant Trajectory based clustering technique for selecting the cluster heads and to extenuate the burning spot problem by prolongs the network lifetime but fails in achieving the robustness [8]. An Integer Linear Programming (ILP) problem obtains the optimal solution. For large-scale network, the ILP is not appropriate, and propose two algorithms to solve it. The first one is a  $\ln(kn)$  estimate algorithm, where  $n$  is the number of sensor nodes. The subsequent is a simple heuristic scheme that has much shorter running time to assess algorithms using extensive simulation [9].

A model to put together data aggregation with the fundamental routing scheme and present a leveling approximation functions for the optimization problem. The essential and enough conditions for achieving the optimality

are resulting and a dispersed gradient algorithm is designed accordingly. By exploiting the special structure of the sensor network, leveling approximate functions conquer the non differentiability of original optimization problem so that the distributed solution is not possible [15]. To overcome all the above issues developed a scheme named Cluster based Energy Competent n- coverage to ensure the full coverage of a monitored area while saving energy.

### III. CEC N-COVERAGE SCHEME

CEC n-coverage scheme sensors are typically positioned with huge number and their sensing areas are overlapped among the neighbors, which leads to a huge number of unnecessary sensors. Hence, activate a reduced number of sensors able to create sure full area coverage and turn off some unnecessary nodes to save energy. The architecture diagram of the CEC n-coverage scheme is shown in Fig. 1.

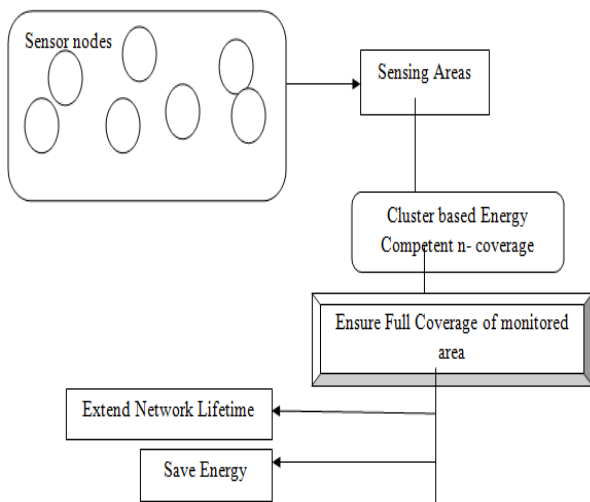

Fig. 1 Architecture Diagram of CEC n-coverage scheme

Furthermore in Fig. 1, shaping a minimum number of active sensors is based on the degree coverage required and its level. If every position in the area is monitored by at least  $n$  ( $n \geq 1$ ) sensors, the sensor network is said to be an  $n$ -coverage sensor network where  $n$  is the coverage degree. Moreover, when the coverage is monitored (i.e.) points not covered in the monitored area. The appearance of these holes is due to failure of sensors or their disabling.

#### A. Notations and Assumptions

Consider a set of wireless sensor nodes  $P = \{p_1, p_2, \dots, p_n\}$ , disseminated in a two-dimensional Euclidean plane  $Q$ . CEC n-coverage scheme define 'C' as the area where sensors are initially deployed. Each sensor is placed in 'C' at coordinates  $(x_i, y_i)$  and it knows its own position. The sensing region of each sensor is a disk, centered at the sensor, with radius  $S$ , its sensing range. Assume that all sensors have the same sensing range 'S' and has Omni-directional antenna.

The sensing region of a sensor  $s_i$  placed at coordinates  $(x_i, y_i)$  is represented by the surface:  $C(p_i) = \{X \in Q \mid d(X, X_i) \leq S\}$

where  $d(X, X_i)$  is the Euclidean distance between sensor  $p_i$  and each point of the plane  $Q$ .  $C(p_i)$  represents the maximal circular area centered at a sensor  $p_i$  that covered by  $p_i$ . The radius of  $C(p_i)$  is called sensor  $p_i$ 's sensing range. It defines the coverage  $C(U)$  of a sensor set  $U = \{p_1, p_2, \dots, p_q\}$ , as the unification of sensing area enclosed by each sensor in  $U$  i.e.  $C(U) = C(p_1) \cup C(p_2) \cup \dots \cup C(p_q)$ . It said that  $U$  covers fully an area of targets  $C$  if and only if  $C \subseteq C(U)$ .

A point  $q \in C$  is  $n$ -covered if it is in the sensing range of at least  $n$  sensors,

$$q \text{ is } n\text{-covered} \Leftrightarrow |\text{Cover}(q)| \geq n \quad (1)$$

where,  $|\text{Cover}(q)|$  is the cardinality of the set  $\text{Cover}(q)$ .

A precise area 'C' is said  $n$ -covered by a set of sensors  $P$  if and simply if every point  $q$  within 'C' is covered by at least  $n$  sensors of  $P$ :

$$C \text{ is } n\text{-covered} \Leftrightarrow \forall q \in C \quad |\text{Cover}(q)| \geq n \quad (2)$$

Considering a number  $n$ ,  $n$ -coverage problem is a decision problem whose goal is to determine if each point in  $C$  is  $n$ -covered or not. Defined an  $n$ -coverage area where  $n$  represents the minimal number of sensors that cover each point  $q$  of the area  $C$ :

$$n = \min \{|\text{cover}(q)| \mid \forall q \in C\} \quad (3)$$

#### B. Cluster Based Energy Competent Algorithm

In the purpose to ensure the area coverage while prolonging network lifetime, proposed a cluster-based energy competent scheme called CEC n-coverage scheduling algorithm, which is used to allow each sensor to switch between active and sleep modes to save energy. Sensors are assumed that they have limited battery energy. Sensing, transmitting and receiving activities consume battery energy of a sensor, and thus border the network lifetime. In work, CEC n-coverage determine the statute of all the deployed sensors to be either active or sleep based on their capabilities as well as the state durations, such that the network lifetime is maximized.

In context, the network lifetime is defined as the time period starting from network set up to the time when the stage of area coverage is lower than a certain threshold. CEC n-coverage selects the active sensors after the election of cluster-heads and the formation of clusters following the algorithm of self-organization. In CEC n-coverage algorithm, addressed the problem of node coverage while CEC n-coverage generalize the aspect and address the problem of area coverage.

In addition, sensors that offer the area coverage would be selected with a distributed manner and according to their weight by their equivalent cluster-heads. The weight of each sensor is a amalgamation of the subsequent parameters:  $n$ -density and residual energy, as presented in (4). CEC n-coverage used the  $n$ -density with  $n=2$  not to weaken algorithm of its presentation and not to augment the overhead. The 2-density of a node symbolize the ratio between the number of links in its 2-hop neighbourhood links between  $w$  and its

neighbours and links between two 2-hop neighbours of  $w$  and 2-degree of  $w$ .

It uses the 2-density as parameter as an alternative of 2-degree to generate homogeneous clusters and to favour the node that has the most 2-neighbors related to become cluster-head. The coefficient of each parameter is chosen depending on the application. For example, in an application where the power is dangerous choose the sensor that has more energy to be cluster-head. Therefore, assign to  $\beta$  a big enough value relatively to  $\alpha$ . In contribution, CEC n-coverage scheme attribute sufficient values to the variety of coefficients in the principle to produce stable clusters where  $\alpha=0.5$ ,  $\beta=0.5$ .

$$\text{Weight}(w) = \alpha * 2\text{-density}(w) + \beta * \text{Energy}(w) \quad (4)$$

with  $\alpha + \beta = 1$ . CEC n-coverage is performed in two phases. The first phase is performed according to the following algorithmic scheme:

// Pseudo-code of the algorithm CEC n-coverage scheme

```

1: For each cluster-head CH do,
2:  $M_2'(CH, D_i) = M_2(CH, D_i)$ 
3:  $\text{Cover}(D_i) = \{CH\}$ 
4: End for
5: While  $\exists w \mid w \in M_2'(CH, D_i) \wedge \exists w \in M_1'(CH, D_i) \mid w \in M_1'(w, D_i)$  do
6:  $\text{Cover}(D_i) = \text{Cover}(D_i) \cup \{w, v\}$ 
7:  $M_2'(CH, D_i) = M_2'(CH, D_i) / \{w\}$ 
8: End while
9: While  $M_2'(CH, D_i) \neq \emptyset$  do
10: Choose  $w \in M_2'(CH, D_i)$ 
11:  $\text{Weight}(w) = \text{Max}(\text{Weight}(w_i) : w_i \in M_2'(CH, D_i))$ 
12:  $\text{Cover}(D_i) = \text{Cover}(D_i) \cup \{w\}$ 
13: Choose  $v \in M_1(w, D_i)$ :
14:  $\text{Weight}(v) = \text{Max}(\text{Weight}(v_i) : v_i \in M_1(w, D_i) : \wedge v_i \notin M_2(CH, D_i)$ 
15: For each  $u \in M_1(w) \wedge u \in M_1(v)$  do
16:  $\text{Cover}(D_i) = \text{Cover}(D_i) \cup \{u\}$ 
17: End for
18:  $M_2'(CH, D_i) = M_2(CH, D_i) / M_1(w, D_i)$ 
19: End while
    
```

$D_i$  is the number of the cluster ( $i$ ), and  $M_2(CH, D_i)$ : the set of the cluster-head CH's 2-neighbors belonging to the cluster  $D_i$ ,  $M_1(CH, D_i)$ : the set of the cluster-head CH's 1-neighbors belonging to the cluster  $D_i$ .  $\text{Cover}(D_i)$  is the position of sensors in the cluster  $C_i$  that is positioned in energetic mode to keep up the coverage area. A sensor switches to energetic mode according to its weight age coverage.

In the second phase of CEC n-coverage scheme, each active sensor classifies its 1-neighbors in ascending order of their weight. Then it checks the numeral of active sensors within its sense area. Let 'u' be the number of sensors in 'w' sensing area. If 'u' is less than the coverage degree  $n$ ,  $w$  would switch to dynamic mode ( $n-u$ ) sensors with the maximum weight in its 1-neighborhood. Then, 'w' would pass in idle mode  $n/2$  inactive sensors that have the maximum weight in its 1-neighborhood. These sensors could restore active sensors

which cease to operate before the expiry of the period 'U' active of their activities.

Moreover, once clusters are formed and active sensors are selected, the data communication phase start on where the active sensors occasionally assemble data and send it to their equivalent cluster-head. The cluster head nodes of CEC n-coverage scheme aggregate the data from the cluster memberships and route the aggregate information packets over the predetermined multi-hop paths to the sink.

### C. Practical Sensor and Monitoring Area Discretization

The n-coverage problem is considered as a NP-hard problem as the first solution consists to find all regions shared by a certain number of sensors and verify that each region is covered by at least  $n$  sensors. However, geometric verification of all regions covered by a number of sensors is a complex task because there may exists many regions shared by several sensors whose number may reach in the worst case  $\theta(n^2)$ . Moreover, it might be difficult to determine these regions.

Our solution consists to discrete the area monitored in several regions and to choose a random position within every region. To verify the n-coverage of every chosen position, suppose that the latter is a practical sensor that exchanges the beacons or Hello messages with its neighborhood to know its degree and consequently the number of sensors that covers it. It represents the coverage degree of the position.

The algorithm associated to CEC n-coverage scheme is performed as follows:

```

Step 1. Discrete the area monitored in numerous squared regions. Let  $m$  the number of these regions.
Step 2. Generate an arbitrary point within every created region by generation of random points using a homogeneous distribution function such as the generate points are homogeneously distributed in the monitored area and their position don't correspond with the already existing sensors or the already generated points.
Step 3. Calculate the n-coverage degree of every practical sensor generated. For that, it is enough to analyze the Euclidean distance between sensor nodes and every sensor positioned within the monitored area.
Step 4. Calculate the degree of area n-coverage such that the practical degree of the area is equal to the minimal degree of the generated practical sensors.
    
```

```

Step 1. For each  $w_i(x_i, y_i) \ i=1, \dots, m$ : practical sensors
    Step 1.1 Calculate  $\delta_1(w_i) = |M_1(w_i)|$  where  $|M_1(w_i)|$  is the number of  $w_i$ 's active neighbors.
Step 2. Calculate the area n-coverage  $\text{Cover}(C)$ 
    Step 2.1  $\text{Cover}(C) = \text{Min} \{ \delta_1(w_i) : i=1, \dots, m \}$ 
Step 3. If  $\text{Cover}(C)$  is equal to zero, then some holes exist within the monitored area  $C$ ,
Step 4. Otherwise the degree of the area coverage is  $\text{Cover}(C)$ .
    
```

Formally, let  $w_i, i=1, \dots, m$  the generated virtual sensors and  $\delta_1(w_i)$  their corresponding degrees. The n-coverage of the area  $C$ , noted  $\text{Cover}(C)$  is equal to the minimal degree of all practical sensors. If  $\text{Cover}(C)$  is equal to zero ( $\text{Cover}(C)=0$ ), then some holes exist within the area monitored.

Predominantly, to make sure the area n-coverage, it suffice that there is at least many active sensor in the n-neighborhood of each virtual sensor.

#### IV. SIMULATION ENVIRONMENT

Simulations are used to analyze and evaluate the performance of the CEC n-coverage scheme. It uses the network simulator named NS2 to simulate the method. A comparative study between the behaviors of the wireless sensor network is examined. The well known NS2 simulation tool is used. It is an isolated event network simulator for networking research. It provides a substantial support to simulate group of protocols.

To verify the each point in the area by sensor nodes, the results are compared with existing Transparent and non-Transparent relay modes (T-NT) Mobile Multi-Hop relay networks. Sensor scheduling activities in NS2 provides a complete development environment for performance evaluation of communication networks and distributed systems. RWM use and standard of the total number of mail sent or received per node as calculated of the communication requirements, and measure resiliency by counting the number of times must run in n-coverage monitored area to detect a single node replication.

The wireless relay nodes were arranged randomly in the field 600m x 600m in the sensor fields. The time for transmitting such a packet is considered and relay nodes were also arranged. The relay nodes performs simulation with 500 simulation seconds, fixed a pause time of 35 simulation seconds with a minimum moving speed of 1 m/s of each node.

In the Random Way Point (RWM) model, each relay node shift to an erratically chosen location with an arbitrarily selected speed between a predefined smallest amount and highest speed. It assumes the normal unit disc bidirectional communication replica and adjust the message range, so that each relay node will have roughly 50 neighbors on average. The purpose of the study investigates the performance of energy efficiency, fault tolerance, and percentage of active sensors to guarantee the area coverage

#### V. RESULTS AND DISCUSSION

Cluster based Energy Competent n- coverage scheme called (CEC n-coverage scheme) is compared with the existing Transparent and non- Transparent relay modes (T-NT) Mobile Multi-Hop relay networks [1] in measuring the effective energy usage while communicating, fault tolerance and active sensor percentage in monitored area. Energy usage for communication is defined as the amount of energy consumed to transfer the information from source sensing node to destination node in wireless sensor network. It is measured in terms of joules (J).

TABLE I  
 ACTIVE NODE COUNT VS. ENERGY EFFICIENCY

Active Node Count	T-NT METHOD	CEC n-coverage scheme
5	21.8	18.3
10	22.2	19.1
15	22.3	19.9
20	23.5	20.1
25	24.4	20.8
30	25.6	22.5
35	27.2	23.4

$$\text{Communication Energy Efficiency} = Es^2$$

where, 'E'=Total no. of data and 's' represents the speed of transferring of data in sensor node.

Fault tolerant is defined as the lowest level of ability to continue operation in the event of a failure in the wireless sensor system. The fault is controlled after recognition of the data loss in between the sensor nodes.

$$\text{Fault Tolerant} = \frac{\text{End Time} - \text{Start Time}}{\text{Group of data sent from Source to Destination}}$$

The number of active sensors and the coverage degree 'n' versus the sensing range, used two distinct sensing ranges of 600m x 600m illustrate the impact of the link density on the performance of CEC n-coverage scheme. It is measured in terms of percentage (%).

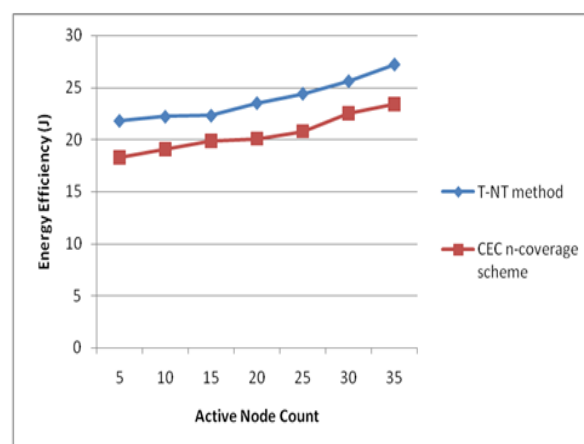

Fig. 2 Active Node Count vs. Energy Efficiency

TABLE II  
 FAULT OCCURRENCE VS. FAULT TOLERANT

Fault Occurrence	T-NT METHOD	CEC n-coverage scheme
7	75	70
11	120	112
16	164	155
18	192	180
22	250	234
29	325	310
70	410	380

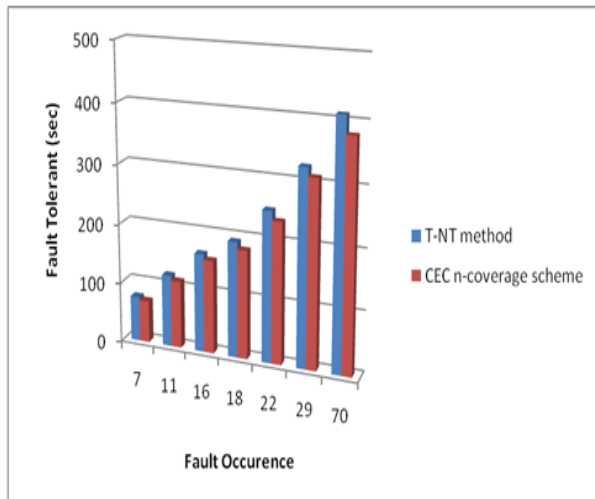

Fig. 3 Fault Occurrence vs. Fault Tolerant

TABLE III  
 NUMBER OF SENSOR NODES VS. % OF ACTIVE SENSOR

No. of sensor nodes	T-NT METHOD	CEC n-coverage scheme
10	75	79
20	76	81
30	78	82
40	82	86
50	84	89
60	85	89
70	85	90

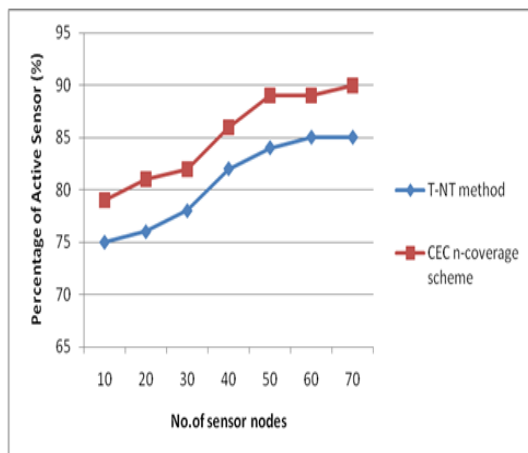

Fig. 4 No. of sensor nodes vs. Percentage of Active Sensors

Fig. 2 describes the communication energy efficiency based on the active node count. CEC n-coverage scheme activate a reduced number of sensors able to create sure full area coverage and turn off some unnecessary nodes to save energy. Likewise, a sensor node sends the data from source sensor node to destination node without the loss of data with minimal energy. The CEC n-coverage scheme energy used to communicate is 10–20% lesser when compared with the T-NT method. The energy consumed is multiplied with  $\beta$  to obtain the Energy ( $w$ ) form of the wireless sensor network.

The fault tolerant of CEC n-coverage scheme and T-NT method are inspected in Fig. 3. CEC n-coverage scheme point  $q \in C$  is n-covered if it is in the sensing range of at least n sensors,  $q$  is n-covered  $\Leftrightarrow |\text{Cover}(q)| \geq n$ , which tolerates the fault in a minimal time. It is measured in terms of seconds (sec). CEC n-coverage scheme 4–8% lesser time taken to reduce the fault tolerant when compared with the T-NT method.

Fig. 4 describes the percentage of active sensors based on the sensor nodes available in the monitored area. CEC n-coverage scheme is 2–5% higher amount of active sensors when compared with the T-NT method. For the n-coverage area,  $\text{Cover}(D_i) = \text{Cover}(D_i) \cup \{w, v\}$  used to increase the percentage of active sensors in CEC n-coverage scheme. Moreover, CEC n-coverage scheme provides better results in terms of percentage of active sensors. Indeed, when the number of sensors arrangement increases, the percentage of active sensors greatly increases.

Finally, Cluster based Energy Competent n- coverage scheme ensure the full coverage of a monitored area while saving energy. CEC n-coverage scheme uses a narrative sensor scheduling scheme based on the n-density and the remaining energy of each sensor decide the state of all the deployed sensors. Simulation results showed that CEC n-coverage scheme in wireless sensor network provides better performance in terms of the energy efficiency; fault tolerant and the percentage of active sensors guarantee the area coverage.

## VI. CONCLUSION

Addresses the n-coverage problem in the monitored area which is more significant than others and require to be covered by more sensors to attain fault tolerance and to agreement with wrong measurements collected by the sensors. The solution proposed test whether a point within the monitored area is n-covered or not. To check n-coverage point, apply the Cluster based Energy Competent n- coverage scheme called (CEC n-coverage scheme) to verify if each virtual sensor has at least n active sensors in its neighborhood. The work presented helped to create sure full coverage of the monitored area, involving a smallest amount number of sensors. As a result, energy consumption is minimized and therefore network lifetime will be extended. To demonstrate the performance of the CEC n-coverage algorithm compared the results obtained by algorithm to the results provided by other efficient algorithms described in the literature. Future work compact with the coverage problem in a mobile environment and study about the complexity and compares it to those of the other protocols. Besides, compute the energy consumption and compare it to those of the other protocols.

## ACKNOWLEDGMENT

We like to thank the management of Coimbatore Institute of Engineering and Technology for providing facility to do research in Networks Laboratory, department of computer science and Engineering.

REFERENCES

- [1] D. Satish Kumar., N. Nagarajan., "Analysis of Transparent and non-Transparent relay modes in IEEE 802.16j Mobile Multi-Hop relay networks," *Journal of Discrete Mathematical Sciences and Cryptography*, 2013
- [2] Fatme El-Moukaddem., Eric Torng., Guoliang Xing., "Mobile Relay Configuration in Data-intensive Wireless Sensor Networks," *IEEE Transactions on Mobile Computing*, 2010
- [3] Chi Lin., Guowei Wu., Feng Xia., Mingchu Li., Lin Yao., Zhongyi Pei., "Energy efficient ant colony algorithms for data aggregation in wireless sensor networks," *Journal of Computer and System Sciences, Elsevier Journal*, 2012
- [4] Yujin Lim., Jaesung Park., Sanghyun Ahn., "Designing the tree-based relaying network in wireless sensor Networks," *International Journal of Energy, Information and Communications* Vol. 1, Issue 1, November, 2010
- [5] Djamel Djenouri., and Ilangko Balasingham., "Traffic-Differentiation-Based Modular QoS Localized Routing for Wireless Sensor Networks," *IEEE Transactions on Mobile Computing*, VOL. 10, NO. 6, JUNE 2011
- [6] Amit Kumar Bindal., Anuj Jain., Dr. Devendra Prasad., Dr. R. B. Patel., "Hierarchical Fault Tolerant Adaptive and Scalable Protocol for Data Dissemination in Wireless Sensor Network: HiFAS," *International Journal of Applied Engineering Research*, ISSN 0973-4562 Vol.7 No.11 (2012)
- [7] Huseyin Ozgur Tan., Ibrahim Korpeoglu., and Ivan Stojmenovi c., "Computing Localized Power Efficient Data Aggregation Trees for Sensor Networks," *IEEE Transactions On Parallel and Distributed Systems*, 2010
- [8] Hazarath Munaga., J. V. R. Murthy., and N. B. Venkateswarlu., "A Fault Tolerant Trajectory Clustering (FTTC) for selecting cluster heads in Wireless Sensor Networks," *International Journal of Computational Intelligence Research*, 2008
- [9] Xian Chen., Yoo-Ah Kim., Bing Wanga., Wei Wei., Zhijie Jerry Shi., Yuan Song., "Fault-tolerant monitor placement for out-of-band wireless sensor network monitoring," *Ad Hoc Networks, Elsevier Journal*, 2012
- [10] Lokesh Sharma., and Swati Agnihotri., "Connectivity and Coverage Preserving Schemes for Surveillance Applications in WSN," *IJCSNS International Journal of Computer Science and Network Security*, VOL.13 No.6, June 2013
- [11] Andreas Konstantinidis., Kun Yang., "Multi-objective K-connected Deployment and Power Assignment in WSNs using a problem-specific constrained evolutionary algorithm based on decomposition," *Computer Communications, Elsevier Journal*, 2010
- [12] Nasim Khazan., Ali Broumandnia Nima Ghazanfari Motlagh., "Node Placement and Coverage in Asymmetrical Area" *International Journal of Advanced Research in Computer Science and Software Engineering*, 2012
- [13] Gianni A., Di Caro., and Eduardo Feo Flushing., "Optimal relay node placement for throughput enhancement in wireless sensor networks," *International Conference on FITCE Congress (FITCE)*, 2011
- [14] Floriano De Rango., Francesca Guerriero., and Peppino Fazio., "Link-Stability and Energy Aware Routing Protocol in Distributed Wireless Networks," *IEEE Transactions on Parallel and Distributed Systems*, VOL. 23, NO. 4, APRIL 2012
- [15] Cunqing Hua and Tak-Shing Peter Yum., "Optimal Routing and Data Aggregation for Maximizing Lifetime of Wireless Sensor Networks," *IEEE/ACM Transactions on Networking*, VOL. 16, NO. 4, AUGUST 2008



**Dr.N.Nagarajan** received his B.Tech and M.E. degrees in Electronics Engineering at M.I.T Chennai. He received his PhD in Faculty of information and communication engineering from Anna University, Chennai. He is currently working as Principal, Coimbatore Institute of Engineering and Technology, Coimbatore. He is member of board of study of faculty of information Technology at Anna University of technology, Coimbatore. His specialization includes optical, wireless Adhoc and sensor networks. He is guiding assorted research scholars in optical networks and wireless networks. Email: [swekalnag@gmail.com](mailto:swekalnag@gmail.com)



**D. Satish Kumar** received his B.E., degree in Electrical and Electronics Engineering from Bharathiar University and M.E. degree in Computer Science and Engineering from Manonmaniam Sundharnar University respectively. He is currently working towards the PhD degree in Computer Science and Engineering in Anna University, Chennai, Tamil Nadu INDIA. His research interests accumulate in the area of

wireless sensor Networks, IEEE 802.16j Multi hop Mobile networks, Routing, WIMAX networks, Network management in wired Networks and Wireless Networks. Email: - [satishcoimbatore@yahoo.co.in](mailto:satishcoimbatore@yahoo.co.in)