

Modal Analysis of Machine Tool Column Using Finite Element Method

Migbar Assefa

Abstract—The performance of a machine tool is eventually assessed by its ability to produce a component of the required geometry in minimum time and at small operating cost. It is customary to base the structural design of any machine tool primarily upon the requirements of static rigidity and minimum natural frequency of vibration. The operating properties of machines like cutting speed, feed and depth of cut as well as the size of the work piece also have to be kept in mind by a machine tool structural designer. This paper presents a novel approach to the design of machine tool column for static and dynamic rigidity requirement. Model evaluation is done effectively through use of General Finite Element Analysis software ANSYS. Studies on machine tool column are used to illustrate finite element based concept evaluation technique. This paper also presents results obtained from the computations of thin walled box type columns that are subjected to torsional and bending loads in case of static analysis and also results from modal analysis. The columns analyzed are square and rectangle based tapered open column, column with cover plate, horizontal partitions and with apertures. For the analysis purpose a total of 70 columns were analyzed for bending, torsional and modal analysis. In this study it is observed that the orientation and aspect ratio of apertures have no significant effect on the static and dynamic rigidity of the machine tool structure.

Keywords—Finite Element Modeling, Modal Analysis, Machine tool structure, Static Analysis.

I. INTRODUCTION

MACHINE tool structures must exhibit high static and dynamic rigidity for obtaining better surface finish and accuracy of work piece. Thus, care must be taken to minimize structural deformations in the machine tool. The need for high dynamic stiffness results from two separate aspects of the machining process. In the first case inadequate dynamic stiffness will result in poor surface finish of the machined parts. In the second case low dynamic stiffness can have more serious consequences when under heavy machining conditions the resulting vibration might be sufficiently high to cause the process to be terminated in order to prevent possible damage to the machine [1].

Currently the widely accepted method of analysis prior to manufacture of an actual machine tool is the model analysis. Based on the results of analysis and experiments on the scale model, suitable modifications are made, by a process of trial and error, to satisfy the design requirements. The complete study of the scale model experimentally only would be quite impractical in view of the large number of variables involved.

Hawassa University is with the Institute of Technology, Department of Mechanical and Industrial Engineering, Ethiopia (phone: 251-916866978; e-mail: megbar458@yahoo.co.uk).

The other suitable and sound method of analysis prior to manufacturing is, by making use of either lumped parameter technique [2] or Finite Element Method with computer aided technique [3]. The main advantage of these techniques is that it provides information similar to that obtained from actual tests to the designers which saves considerable time and expenditure involving in building and testing models.

Martin [4] was the first to demonstrate the suitability of reduced scale plastic models for predicting the static and dynamic characteristics of machine tool structures. His studies on a quarter scale perspex model of a knee type horizontal milling machine revealed weak points in the actual structure that needed modifications to obtain a sound design. By using classical beam theory J.C. Maltbaek, [5] calculated the natural frequencies and mode shapes of the radial drilling machine structure. The first publication describing a formalized digital computer method for calculating static and dynamic characteristics of machine tool structures appeared in 1964. In this paper, Taylor and Tobias [6] described the application of a finite-element program to represent the structural part of a radial arm drilling machine and a lathe and also performed tests on a series of perspex models of radial drilling machine and lathe structures to verify the accuracy of the numerical technique developed by them and to predict the behavior of the structure at the design stage itself. An excellent agreement between experimental and computed modal shapes and natural frequencies of vibrations was reported.

Badawi, Mohsin and Thornly, [7] developed analytical models to predict the bending and torsional stiffness of ribbed beams. These models have further been used to study the influence of various geometric dimensions and ribbing configuration on their stiffness characteristics with a view to obtain their optimized proportions in terms of stiffness per unit weight as the criterion. N. Ganesan and his coworkers [8] present the analysis of prismatic columns for their torsional behavior. Such columns are widely used in the design of machine tools. In this work the prismatic column was treated as a closed thin-walled beam and the problem is solved by using variational methods in conjunction with the finite difference technique.

Cowley and Fawcett [9] analyzed a plano-milling machine structure for static deflections, natural frequencies and mode shapes and studied the effect of flexibilities between joints on the natural frequencies and mode shapes. The main portal frame is comprised of two 12ft (3.6576m) tapered columns spanned by a 7ft (2.1336m) cross-beam and carries an adjustable height cross-slide. The cast iron structure supports three traversing 50hp ram type milling heads with provision

for limited ram extension. A program was developed for computing the static and dynamic characteristics of machine tool structures and optimum design was pursued with respect to those characteristics by Yoshimura Matasaka [10]. In this reference, the author analyzed double column type milling and boring machines. The optimum design and reliability analysis of knee type milling machine tool structures and Warren type lathe beds were made by Reddy and Rao [11].

J. N. Dube [12] employed numerical analysis of the milling machine structure to determine its dynamic characteristics. The eigenvalues and eigenvectors are obtained by iteration method. The results he obtained are compared analytically and experimentally with those for a one-quarter-scaled perspex model of the Elliot Universal milling machine structure, for the lowest 12 natural frequencies and their mode shapes. The results of the scaled model are compared with those for the original structure using the laws of dynamic similarity.

M. Yoshimura and T. Hoshi [13] developed computer programs for computing the dynamics characteristics of three-dimensional structures. The computer program system is based on the principles of synthesis of receptance.

Ramana G. V. and Rao S. S. [14] used finite element analysis to demonstrate the feasibility of optimum design of Plano milling machine tool structures with multiple behavior constraints. The computer program developed is quite general and the elements used for idealization are sufficiently general to idealize any type of milling machine tool structure. The authors idealize the column and overarm of plano-milling machine as triangular plate element these members have sufficient width while the frame elements are used for representing the cross-slide.

Many researchers have studied the stiffness of machine tools by experimental, analytical or numerical methods in the past. A Report which includes the detailed technical know-how for analyzing the stiffness of machine tools by applied numerical method, namely, the computer aided engineering (CAE), has been presented by David Te-Yen Huang and Jyh-Jon Lee. In this paper two methods, namely single module method (SMM) and a hybrid modeling method (HMM) have been introduced. The techniques include building suitable finite element models, determining nodal forces, transforming and applying equivalent loads, simulating the interface between two modules, considering the boundary constraints, and interpreting results. HMM appears to be superior to SMM. K. Mao et al. [15] proposed a new dynamic modeling method of the fixed joints in machine tools. The authors in this work studied a universal dynamic model of fixed joints by considering the relative motion between the sub-structures of the fixed joints and the coupling among various degrees of freedom. The authors also validated the effectiveness and accuracy of the dynamic model and its parameter identification.

II. TYPE OF ELEMENT USED

In this study, shell elements are used because these elements represent a structure that is relatively thin as

compared with its length and width and also has a constant cross section and thickness.

The formulation of this element is based on the theory of plates with transverse shear deformations. This theory uses the assumptions that particles of the plate originally on a straight line that is normal to the undeformed middle surface remain on a straight line during deformation Bath [16]. Shell elements are created by compressing opposed surfaces to a common mid surface. The general finite element software ANSYS places elements on the mid surface only, using the thickness associated with each portion of the shell to determine the depth of the elements. If the model includes a meeting of more than two surface pairs, it is important to have the compressed mid surfaces all intersect at a common point or axis. If they do not, ANSYS [17] may fail to generate the proper geometry and either not run at all or produce unrealistic results. The basic elements used to create shells are fast running triangles or quadrilaterals. As with beam elements, spurious shear stresses are predicted with the displacement-based elements. These spurious shear stresses result in a strong artificial stiffening of the elements as the thickness-to-length decreases Bathe 1996.

As per ANSYS, SHELL63 element has both bending and membrane capabilities. Both in-plane and normal loads are permitted. The element has six degrees of freedom at each node: translations in the nodal x, y, and z directions and rotations about the nodal x, y, and z-axes. Fig. 1 shows shell element.

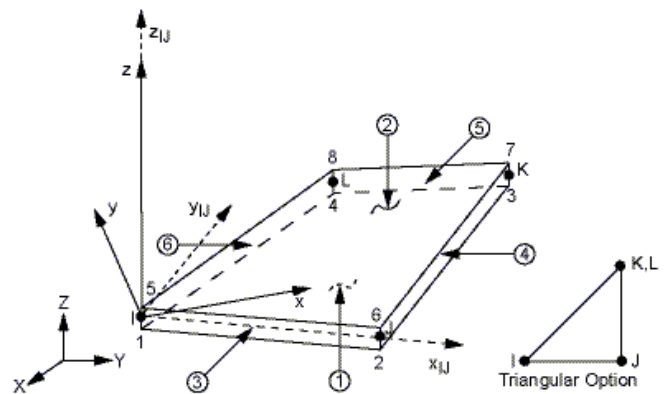

Fig. 1 Shell63 geometry as per ANSYS

III. TYPE OF COLUMN ANALYZED

Basically 6 columns (Straight column with rectangle and square base, column with ab/cd ratio of 1/2 and 3/4 for each square and rectangular base) have been selected for the present study and the column shapes are illustrated in Fig. 2 and the necessary dimensions are tabulated in Table I. Each of the above columns has been analyzed in the following variants.

Open type with taper of 1/2, 3/4 and 1 (i.e. Ratio of ab/cd=1/2,3/4,1)

- (i) With uniform cover plate (Ratio of ab/cd=1/2,3/4,1)
- (ii) With uniform cover plate and four uniform transverse partitions.

In all the above cases the base of the column has two geometries (square and rectangular) two aperture sizes (400x400 and 600x600) in three different locations.

TABLE I
 DIMENSIONS OF COLUMNS [18]

Side	Base Geometry	Width (W) in mm	Depth (D) in mm	Thickness (t) in mm	Height (H) in mm
ch	Square	-	-	-	H/3
	Rectangular	-	-	-	H/3
cd	Square	1346.2	1346.2	120	3658
	Rectangular	1346.2	1346.2/2	120	3658

Fig. 2 below shows types of columns used in this study:

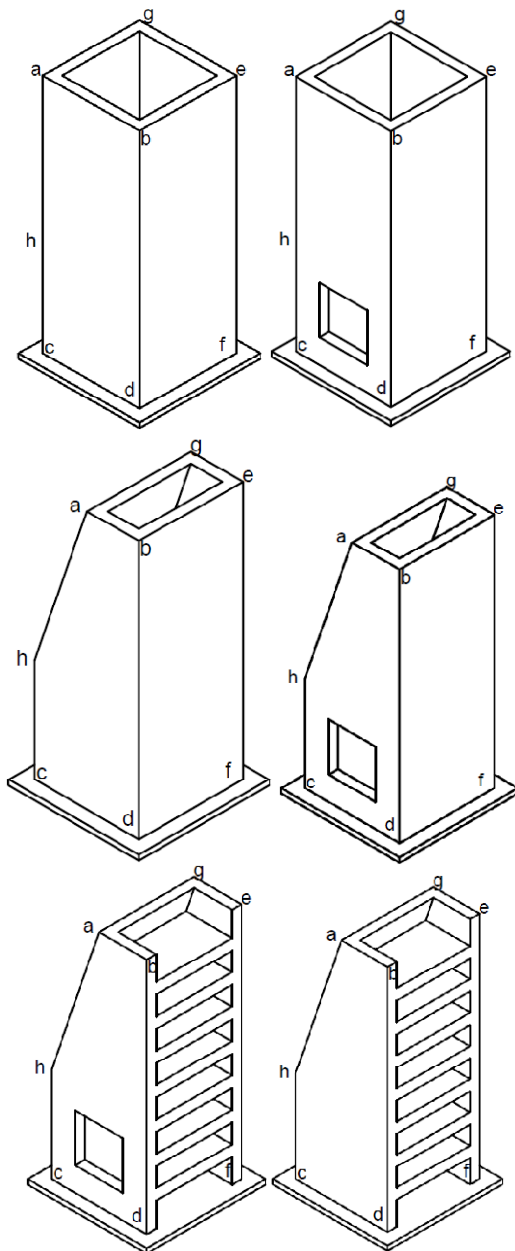

Fig. 2 Different types of columns with and without apertures

The material selected for machine tool structure must resist deformation and fracture, hardness must be balanced against elasticity, the material must block vibration transmission to reduce oscillations that degrade accuracy and tool life, and it must withstand hostile environments, like new coolants and lubricants [19].

Almost all machine tool columns were traditionally made of cast iron because features difficult to obtain any other way can be cast in. In this study the material of the structures is assumed to be cast iron with density, $\rho=7.15 \times 10^3 \text{Kg/m}^3$, modulus of elasticity $E=11.76 \times 10^4 \text{MPa}$ and Poisson's ratio, $\nu=0.211$.

IV. TYPES OF ANALYSIS

In this study two types of analysis were used, static and modal.

A. Static Analysis

Static analysis was carried out to determine the bending and torsional deformation of machine tool columns [20]. In this study bending and torsional loads are assumed to be applied at the free end of the columns by taking in to account different parameters like, variation of tapers, aspect ratio, size and orientation of apertures etc.

In static analysis, Evaluation of element stiffness characteristics can be explained by the following steps:

(a) Selection of Suitable Displacement Function:

A displacement function that uniquely defines the state of displacement at all points within the element, including the boundaries, is chosen. The choice of this assumed function greatly affects the accuracy of analysis because the final algebraic equations are derived from it.

The displacement pattern is most commonly represented by a polynomial expression. To express the displacement at any point in terms of the nodal displacements, the assumed polynomial must contain one unknown coefficient for each degree of freedom possessed by the element. The displacement at any point within the element may be expressed as:

$$\{q(x, y)\} = [f(x, y)]\{\alpha\} \quad (1)$$

where, $\{\alpha\}$ is the column vector of the unknown coefficients (or generalized coordinates) of polynomial function $\{f(x, y)\}$.

(b) Relate the General, Displacements within an Element to Its Nodal Displacements:

Since $\{q(x, y)\}$ represents the displacement at any point, the nodal displacement can be obtained by substituting nodal coordinates in (1). Thus,

$$\{q\}^e = [A]\{\alpha\}$$

where $[A]$ depends up on the coordinates of the nodes and is known. Accordingly,

$$\{q(x, y)\} = [f(x, y)][A]^{-1}\{q\}^e = N\{q\}^e \quad (2)$$

The components of [N] are the 'shape functions' which in general are functions of position.

(c) *Strain-Displacement Relationships:*

With the displacements known at the points within the element the strains (or curvatures) are:

$$\{\varepsilon(x, y)\} = \{differential\ of\ q(x, y)\}$$

The exact form of the above expression for a particular type of problem is obtained from the theory of elasticity.

Using (2), the strain vector is

$$\{\varepsilon(x, y)\} = \{differential\ of\ [N]\{q\}^e\} \text{ OR}$$

$$\{\varepsilon(x, y)\} = [B]\{q\}^e \quad (3)$$

(d) *Relation between the Nodal Loads and Nodal Displacements:*

By imposing virtual displacements and applying the principle of virtual work or by using the principle of minimum potential energy (variational formulation), the nodal loads are related to nodal displacements as

$$\{Q\}^e = [K]\{q\}^e \quad (4)$$

where, the element stiffness matrix [K]^e is

$$[K]^e = \int_v [B]^T [D][B] dv \quad (5)$$

where, [B] is a matrix relating strain and displacement.

(e) *Assembly of Elements into over All Structure:*

By appropriate superposition of the individual element stiffness matrices, the corresponding relationship for the entire assemblage is

$$\{Q\} = [K]\{q\} \quad (6)$$

where [K] is the stiffness matrix for the complete structure assembled from sub-matrices.

$$[K] = \sum_{e=1}^n [K]^e \quad (7)$$

All the quantities in (7) are expressed in a common coordinate system. This system of algebraic equations is solved simultaneously for nodal displacements.

1. Loading of the Columns

The columns are clamped at one end and subjected to both bending and torsion at the free end as shown in Figs. 3 (a) and (b). In the static analysis the load applied in each case are as follows:

(i) *Bending Analysis*

Columns are assumed to be loaded such that identical forces P₁=P₂=1560N act at the points b and e as shown in Fig. 3 (a). The forces act in the direction opposite to that of the positive X axis.

(ii) *Torsional Analysis*

Columns are assumed to be loaded such that one of the forces is reversed and P₁= -P₂=1560N this subjects the column to twisting moments Fig. 3 (b).

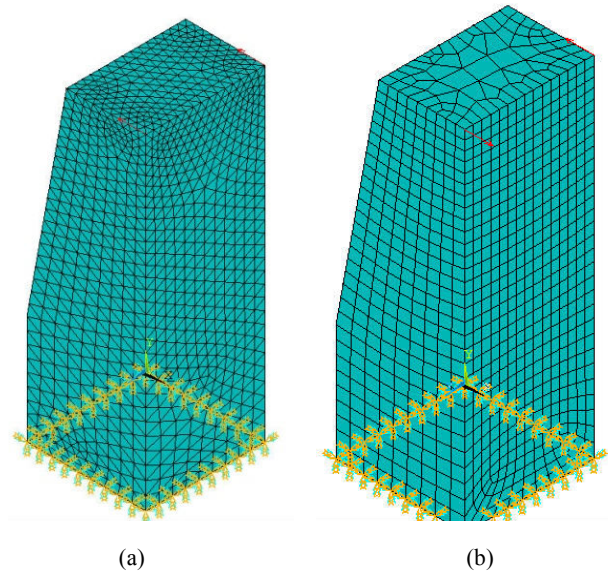

Fig. 3 Mesh representation of machine tool column in bending (a) and in torsion (b)

B. Modal Analysis

Modal Analysis was carried out to compute the natural frequencies and mode shapes of the machine tool column. Machine-tool column can be discretized into finite-element computing modes composed of membrane, plate, shell, bar and beam according to their actual structure. The modal analysis in ANSYS is a mode-frequency analysis and it assumes constant stiffness and mass, no damping and free vibration governed by the equation of motion [21]:

$$[M]\{\ddot{q}\} + [K]\{q\} = 0 \quad (8)$$

where [M] and [K] are global mass and stiffness matrices respectively, and {q} and {q̈} represents displacement and acceleration for all elements of the structure as a whole. The element mass matrix is given by:

$$[\hat{m}] = \int_v \rho [N]^T [N] dv \quad (9)$$

and the element stiffness matrix [K] is obtained through the following formulation:

$$[K]^e = \int_v [B]^T [D] [B] dv \quad (10)$$

where ρ is density of the material, N is a suitable and valid shape function such that $\{u^*\} = [N] \{X\}$ where u^* represents displacement field vector for an element while $\{X\}$ is matrix of displacement vector, $[D]$ is elasticity matrix and $[B]$ is given by $\{\epsilon\} = [B] \{X\}$ in which $\{\epsilon\}$ is a matrix of element strain vector, and v stands for volume. The column of machine tool structure was discretized with ANSYS 10.0 software. Analysis was done on the basis of the formulation discussed above, which finally takes the form of classic Eigen-value problem. If the displacement of each node is expressed in amplitude X , angular frequency ω and initial phase angle ϕ , the matrix form is written as:

$$\{q\} = [X] \sin(\omega t + \phi) \quad (11)$$

From (8) and (11) we obtain:

$$[K][X] = \omega^2 [M][X] \quad (12)$$

Equation (12) expresses the classical Eigen-value problem and can be satisfied by either

$$[X] = 0 \text{ or } |[K] - \omega^2 [M]| = 0 \quad (13)$$

where $| |$ is the determinant of a given matrix. The first case is trivial and the second case represented by (13) yields n Eigen values, ω_i^2 ($i = 1, 2, \dots, n$), which in turn give the natural frequencies, ω_i . For each natural frequency, an eigenvector can be found that defines the mode shape of the system. Such a vector is not unique in the sense that if one eigenvector is a solution, then a constant multiple of that vector is also a solution.

In this paper the column of a machine tool was modeled as a 3-D structure. The element used for this purpose was shell63. The finite element meshing of the column is shown in Fig. 3. Appropriate boundary conditions have been applied at one end of the column for modal analysis. By means of the general finite element software ANSYS10.0, analysis was performed on the basis of the formulation discussed above. The first six modes of vibration were determined together with the corresponding frequencies. The algorithm used for obtaining the Eigen solution was the subspace method described fully in the ANSYS manual.

To verify the accuracy and reliability of our finite element model, the following illustrative examples have been carried out.

Examples

1. Deformation analysis of thin walled column

To check the accuracy of the finite element idealization, a test problem with known solution were performed with the help of ANSYS 10.0. It is observed from the analysis that the maximum deflection values obtained using finite element

solution in this test problem converges to a value some 0.34% higher than the theoretical results obtained by Cowley and Hinduja [22] in torsion and 6% higher in case of bending which is quite an acceptable result.

2. Free vibration of a cantilever beam

In case of vibration modes, the cantilever beam shown in Fig. 4 which is made from cast iron has been chosen. The computed results are shown in Table III.

The fundamental frequency, f_n , of a simple cantilever beam is given by:

$$f_n = \frac{k_n^2}{2\pi} \sqrt{\frac{EI}{\rho AL^4}} \quad (14)$$

where n denotes the corresponding mode and I denotes the moment of inertia of the beam cross section and is defined for a beam with rectangular cross section as:

$$I = \frac{BH^3}{12}$$

From the tables of hyperbolic and trigonometric functions [23], the values of k_n for the first five modes of a cantilever beam are: $\kappa_1=1.875$, $\kappa_2=4.694$, $\kappa_3=7.855$, $\kappa_4=10.996$, $\kappa_5=14.137$. The corresponding modal shapes for the first five frequencies are shown in Table III. The Material and physical properties of cantilever beam are given in Table II.

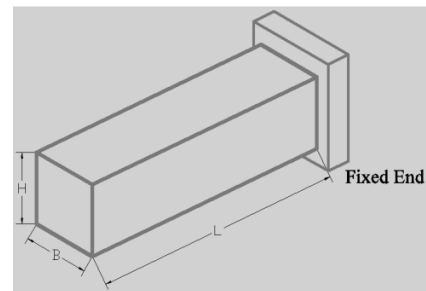

Fig. 4 Cantilever beam with rectangular cross-section.

TABLE II
 MATERIAL AND PHYSICAL PROPERTIES OF CANTILEVER BEAM [24]

Material	Cast iron
Young's Modulus	2×10^6 kg/cm ²
Poisson's Ratio	0.22
Moment of Inertia Ixx	0.0833cm ⁴
Moment of Inertia Iyy	0.0833cm ⁴
Density	7.8×10^{-3} kg/cm ³
Breadth (B)	1cm
Depth (B)	1cm
Cross-sectional Area	1cm ²
Length (L)	10cm

TABLE III
COMPARISON OF NATURAL FREQUENCIES OF COMPUTED RESULTS WITH RESULTS FROM ANSYS

Order Number	Natural Frequencies in HZ		Percentage Error
	Analytical solution (from closed form solution)	Results from ANSYS	
1 st order	810	808.46	0.19%
2 nd order	5060	5009.2	1.004%
1 st order longitudinal vibration	12500	12551	0.408%
3 rd order bending	14160	13781	2.67%
4 th order bending	27800	26354	5.2%

V. PARAMETRIC STUDY

The effect of the variation of the following parameters on the Static and Dynamic rigidity characteristics was studied.

- i) Variation of taper
- ii) Orientation of Apertures
- iii) Aspect Ratio
- iv) Size of Apertures

The variations in these parameters are obtained as follows:

1. Taper: the taper for the columns is varied in such a way as to obtain two ratios of sides *ab* and *cd* as shown in Fig. 2. $ab/cd = 1/2, 3/4$. The length of side *ab* is so adjusted that two ratios of *ab/cd* are obtained in each case length of side *ab* is equal to *eg*.
2. Orientation of Apertures: two identical apertures of size 400x400 are situated on the walls of *abcd* and *efgh*. At first the center of the aperture on the wall *abcd* is taken at point 'o' coordinate (673.1, 609.5, 1346.2). The next positions of the aperture are taken with centers at 'o1' (673.1, 409.5, 1346.2) and 'o2' (673.1, 1009.5, 1346.2). In each case the center of the aperture on wall *efgh* is kept at a point exactly opposite to center of aperture on wall *abcd*. The size and the aspect ratio of apertures are kept the same in each case.
3. Aspect ratio of opening: for this study the identical openings are situated exactly opposite to each other with centers at 'o' and 'o1'. The following aspect ratios are studied: 0.6, 0.75, 1.0, 1.25, and 1.5. In each case the areas of apertures are kept the same.
4. Size of openings: For this study the openings are kept with centers at O and O1. At first size of each opening is 400x400 and in the second case size of each of the apertures is 600x600.

VI. RESULTS AND DISCUSSIONS

The results of the study are shown through Tables IV to XI [20], [21] for bending and torsional analysis, the displacement at points *b* and *e* are given in mm.

In addition to the tables, graphs are plotted that shows how the deformations in the *x* direction along the line *bd* and *ef* are affected by the presence and size of apertures for bending and torsional analysis as shown through Figs. 5 to 8. Modal results of the study are shown through Tables XII to XV. The natural

frequencies and deformed shapes of the first six modes of vibration were computed for all the columns that dealt with in the static analysis. The mode shapes obtained for column with *ab/cd* of 3/4, aperture and cover plate are shown in Fig. 9. The characteristic shape of all the modes remained substantially the same for all columns analyzed although the relative magnitude of displacements varied. The computed values of frequencies of the machine tool column are given through Tables XII to XV. The first mode of vibration is characterized by a rocking motion in the *Z* direction. The second mode shows a longitudinal vibration mode and the third and sixth modes are characterized by out of plane deformation. The fourth mode is characterized by twisting of the column and the fifth mode is characterized by bending mode in the *X* direction.

A. Static Results

1. Bending Results

TABLE IV
EFFECT OF VARIATION OF TAPERS

Ratio of sides <i>ab/cd</i>	Square base column Displacement in mm		Square base column Displacement in mm	
	Open Column	Column with Cover plate	Open Column	Column with Cover plate
1/2	0.00389	0.00368	0.0053	0.00513
3/4	0.00369	0.00349	0.00508	0.00488
1	0.00347	0.00325	0.00458	0.00458

TABLE V
EFFECT OF LOCATION OF APERTURE

Location of the opening	Square base column of <i>ab/cd=1/2</i> Displacement in mm		Square base column of <i>ab/cd=3/4</i> Displacement in mm		Square base column of <i>ab/cd=1</i> Displacement in mm	
	Open Column	Column with Cover plate	Open Column	Column with Cover plate	Open Column	Column with Cover plate
O ₁	0.00402	0.0037	0.00383	0.00359	0.003606	0.00338
O	0.00404	0.00381	0.004045	0.0038137	0.00376	0.00341
O ₂	0.00406	0.00381	0.00385	0.00362	0.00406	0.00381

TABLE VI
EFFECT OF ASPECT RATIO

Aspect Ratio	Square base column of <i>ab/cd=1/2</i> Displacement in mm		Square base column of <i>ab/cd=1</i> Displacement in mm	
	Open Column	Column with Cover plate	Open Column	Column with Cover plate
0.6	0.004	0.00372	0.00357	0.00334
0.75	0.00402	0.00377	0.00358	0.00336
1.0	0.00404	0.00381	0.00376	0.00341
1.25	0.00411	0.00387	0.00368	0.00346
1.5	0.00417	0.00393	0.00375	0.00353

TABLE VII
 EFFECT OF SIZE OF THE APERTURE

Aperture size	Square base column of $ab/cd=1/2$ Displacement in mm		Rectangular base column Displacement in mm	
	Open Column	Column with Cover plate	Open Column	Column with Cover plate
400x400	0.00404	0.00381	0.00547	0.00527
600x600	0.00432	0.00411	0.00581	0.00562

2. Torsional Results

TABLE VIII
 EFFECT OF VARIATION OF TAPERS

Ratio of sides ab/cd	Square base column Displacement in mm		Rectangular base column Displacement in mm	
	Open Column	Column with Cover plate	Open Column	Column with Cover plate
1/2	0.00206	0.000808	0.00112	0.00075
3/4	0.00231	0.000736	0.00118	0.000711
1	0.00274	0.000645	0.00142	0.000656

TABLE IX
 EFFECT OF LOCATION OF APERTURES

Location of the opening	Square base column Displacement in mm		Rectangular base column Displacement in mm		Square base column Displacement in mm	
	Open Column	Column with Cover plate	Open Column	Column with Cover plate	Open Column	Column with Cover plate
O ₁	0.0027	0.000817	0.00232	0.00075	0.00276	0.000678
O	0.00208	0.000818	0.002324	0.000753	0.00287	0.000682
O ₂	0.00208	0.000823	0.002324	0.000754	0.00276	0.000683

TABLE X
 EFFECT OF ASPECT RATIO

Aspect Ratio	Square base column Displacement in mm		Rectangular base column Displacement in mm	
	Open Column	Column with Cover plate	Open Column	Column with Cover plate
0.6	0.0020875	0.000799	0.00276	0.000667
0.75	0.0020884	0.00081704	0.00276	0.000672
1.0	0.0020713	0.00081889	0.00288	0.000683
1.25	0.0020908	0.00083041	0.00276	0.000696
1.5	0.0020921	0.00084003	0.00277	0.000711

TABLE XI
 EFFECT OF ASPECT RATIO

Aspect Ratio	Square base column of $ab/cd=1/2$ Displacement in mm		Rectangular base column Displacement in mm	
	Open Column	Column with Cover plate	Open Column	Column with Cover plate
400x400	0.0020713	0.00081889	0.0011375	0.00078807
600x600	0.0020776	0.00086738	0.0011039	0.00085394

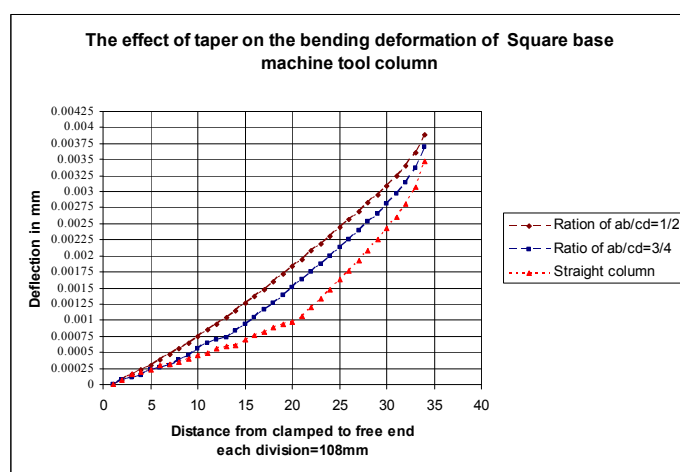

Fig. 6 The effect of taper on the bending deformation of square base machine tool column

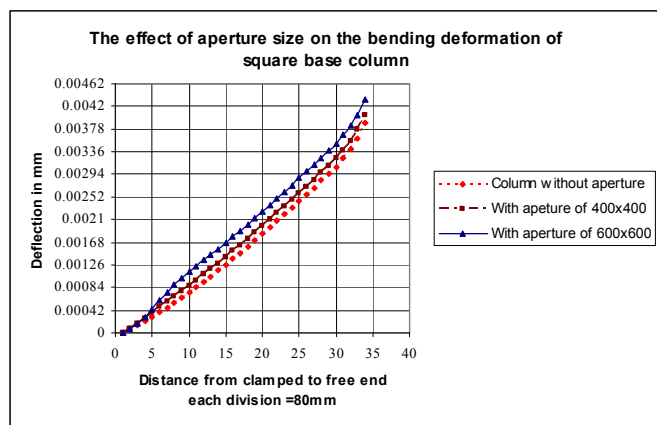

Fig. 5 The effect of aperture size on the bending deformation of square base column

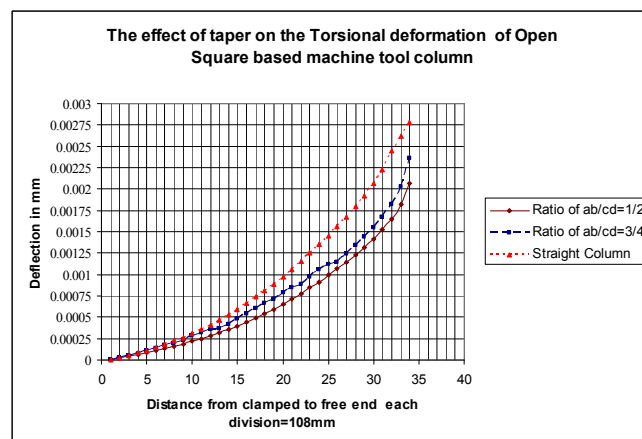

Fig.7 The effect of taper on the torsional deformation of square base machine tool column

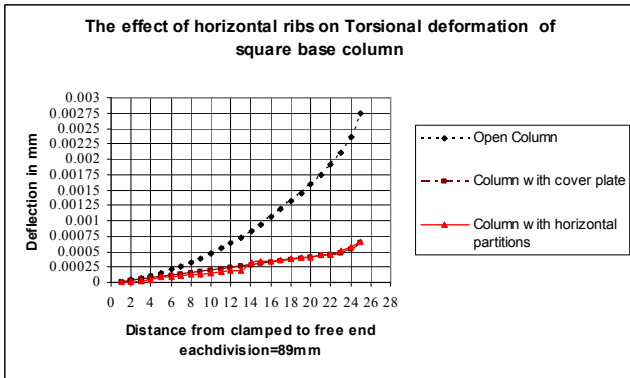

Fig. 8 The effect of horizontal ribs on the torsional deformation of square base machine tool column

B. Modal Analysis Results

TABLE XII
EFFECT OF VARIATION OF TAPERS

Ratio of ab/cd	Modes of Square base Open Column with apertures					
	1 st	2 nd	3 rd	4 th	5 th	6 th
1/2	2.2574	2.3367	3.9525	5.0107	5.488	5.8481
3/4	2.2212	2.2819	3.4276	4.7416	5.1685	5.6865
1	2.1119	2.1347	2.7941	4.039	4.5139	5.1729
Modes of Square base Open Column with cover and apertures						
1/2	2.1061	2.1569	5.1347	5.3041	5.8715	5.9557
3/4	2.0408	2.0702	4.952	4.9816	5.801	5.8437
1	1.9043	1.9046	4.3499	4.5838	5.5771	5.7389
Modes of Rectangular base Open Column with Apertures						
1/2	1.466	2.4423	4.8446	5.5686	7.2923	7.5368
3/4	1.4087	2.3553	4.3735	5.4135	6.8164	6.9814
1	1.2924	2.1693	3.4386	5.0671	5.6151	5.7366
Modes of Rectangular base Column with cover and apertures						
1/2	1.3721	2.2901	4.868	5.374	7.2066	7.3325
3/4	1.3029	2.1872	4.5694	5.191	6.9843	7.0958
1	1.175	1.9815	3.9313	4.8731	6.1803	6.2035

TABLE XIII
EFFECT OF LOCATION OF APERTURES

Modes of Square base Open Column with ab/cd=1/2						
Location of the opening	1 st	2 nd	3 rd	4 th	5 th	6 th
O ₁	2.2721	2.3379	3.9589	5.0075	5.4912	5.8479
O	2.3742	2.4485	4.0013	5.0264	5.7142	5.9663
O ₂	2.2611	2.3434	3.9556	5.0081	5.5052	5.869
Modes of Square base with cover of ab/cd=1/2						
O1	2.119	2.1587	5.1303	5.3159	5.8738	5.9704
O	2.1061	2.1569	5.1347	5.3041	5.8715	5.9557
O2	2.1091	2.1622	5.1331	5.3283	5.9096	5.9728
Modes of Square base Open Column with ab/cd=3/4						
O1	2.2361	2.2826	3.4324	4.7399	5.1779	5.6813
O	2.3371	2.3873	3.4599	4.7499	5.4462	5.7301
O2	2.2239	2.2889	3.4292	4.7381	5.1856	5.6929
Modes of Square base with cover of ab/cd=3/4						
O1	2.0536	2.0716	4.9483	4.9982	5.8028	5.858
O	2.0408	2.0702	4.952	4.9816	5.801	5.8437
O2	2.0428	2.0757	4.9475	5.0012	5.8442	5.8592

TABLE XIV
EFFECT OF APERTURE SIZE

Modes of open straight square base Column with aperture						
Aperture Size	1 st	2 nd	3 rd	4 th	5 th	6 th
400X400	2.1119	2.1347	2.7941	4.039	4.5139	5.1729
600X600	1.7643	1.813	3.8541	4.5691	5.2053	5.6304
Modes of straight Square base Column with cover and aperture						
400x400	1.9043	1.9046	4.3499	4.5838	5.5771	5.7389
600x600	1.7643	1.813	3.8541	4.5691	5.2053	5.6304
Modes of Open Square base Column with aperture of ab/cd=1/2						
400x400	2.2574	2.3367	3.9525	5.0107	5.488	5.8481
600x600	2.0772	2.2152	3.8597	4.9796	5.1186	5.6002

TABLE XV
EFFECT OF ASPECT RATIO

Modes of Square base Open Column of ab/cd=1/2						
Aspect Ratio	1 st	2 nd	3 rd	4 th	5 th	6 th
0.6	2.3039	2.3537	3.972	5.0179	5.5801	5.9038
0.75	2.2879	2.347	3.9655	5.0155	5.5477	5.8851
1.0	2.2574	2.3367	3.9525	5.0107	5.4880	5.8481
1.25	2.2212	2.3257	3.9363	5.0035	5.4162	5.8007
1.5	2.1814	2.3156	3.9175	4.9951	5.3384	5.7489
Modes of Square base Column with cover of ab/cd=1/2						
0.6	2.1553	2.1827	5.1462	5.4429	5.9971	6.0836
0.75	2.1323	2.1667	5.1442	5.3873	5.9194	6.0005
1.0	2.1061	2.1569	5.1347	5.3041	5.8715	5.9557
1.25	2.0748	2.1463	5.1210	5.1986	5.7971	5.9169
1.5	2.0404	2.1366	5.0805	5.1047	5.7260	5.8882
Modes of Square base straight Open Column						
0.6	2.1562	2.1713	2.8087	4.0390	4.6799	5.172
0.75	2.1514	2.1559	2.8063	4.0389	4.6334	5.1709
1.0	2.1119	2.1347	2.7941	4.0390	4.5139	5.1729
1.25	2.0920	2.1374	2.7950	4.0362	4.4507	5.1643
1.5	2.0536	2.1317	2.7875	4.0341	4.3482	5.01596
Modes of Square base straight Column with cover						
0.6	1.916	1.9392	4.4825	4.5878	5.6946	5.8024
0.75	1.9113	1.9269	4.4350	4.5869	5.6512	5.7780
1.0	1.9043	1.9046	4.3499	4.5838	5.5771	5.7389
1.25	1.8755	1.8977	4.2438	4.5787	5.495	5.7021
1.5	1.8444	1.8921	4.1342	4.5724	5.417	5.6699

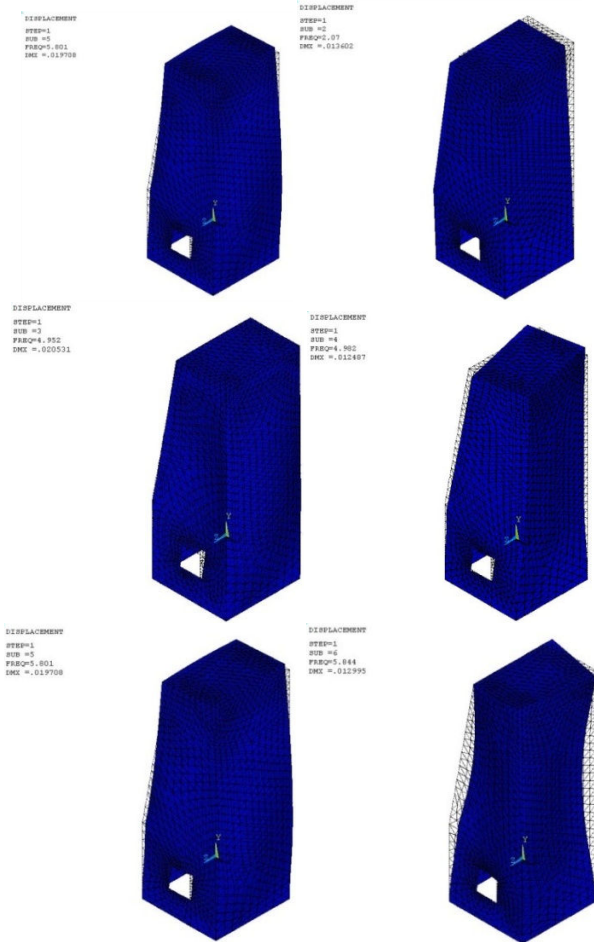

Fig. 9 The first six natural frequencies and mode shapes of machine tool column with ab/cd of 3/4, aperture and cover plate

On the basis of the results of the parametric study, the following observations can be made.

1. Variation of tapers: Results in Tables IV and VIII and also Figs. 4 (a), (b) and 5 (a), (b) show that there is a decrease in torsional and bending rigidity due to increase of taper. It is also observed that an increase in taper results in a decrease in dynamic rigidity as shown in Table XII.
2. Orientation of apertures: results of Tables V and IX show that the change of orientation of the aperture studied in the three cases has very little effect on the torsional and bending rigidity of the columns. It is also observed that the orientation of apertures has a little effect on the natural frequencies of the columns as indicated in Table XII.
3. Aspect ratio of apertures: results in Tables VI and X shows that the aspect ratio of the openings has no effect on the rigidity of the columns when the area of the opening remains unaltered. The aspect ratio of the openings has no significant effect on the natural frequencies of the machine tool column as indicated in Table XV.
4. Size of Apertures: Observations of the plots of deformations along the length of columns for different

sizes of apertures show that the size of aperture has considerable effect over deformations near the apertures. Aperture size also affects the dynamic rigidity as shown in Tables VII and XII and also Figs. 3 (a) and (b). The size of apertures has a considerable effect on the natural frequencies of vibration. As size of the aperture increases the natural frequencies decreases.

It is also observed that the provision of horizontal partition has a considerable improvement on the torsional stiffness of the structure as shown in Fig 6.

VII. CONCLUSION

In this work the generalized finite element software ANSYS has been used to the parametric study. On the basis of the parametric study it is observed that taper, opening and its size are the important factors that need to be considered in the design of machine tool column. The orientation and aspect ratio of apertures have no significant effect on the static and dynamic rigidity of the machine tool structure and hence can be chosen according to functional requirements. On the other hand the size of aperture has an influence on the static and dynamic rigidity of the machine tool column and hence attentions need to be given by the machine tool structural designer.

REFERENCES

- [1] A. Myers, D.G. Ford and Q. Xu; Finite Element Analysis of the structural dynamics of a vertical Milling Machine, International Conference on Laser Metrology, Machine Tool, CMM, and Robot Performance VI; 2003.
- [2] Taylor S. and S.A. Tobias, 'Lumped-constants method for the prediction of the vibration characteristics of machine tool structures', Proc. 5th Int. M.T.D.R., Conf., pp.01-015, 1964.
- [3] David Te-Yen Huang and Jyh-Jon Lee, "On obtaining machine tool stiffness by CAE techniques", Int. J. of Machine Tools & Manufacture, Vol.41, pp.1149-1163, 2001.
- [4] Martin, H., 1962. 'The use of modals for analysis of machine tool structures', Int. J. M.T.D.R., Vol. 2, pp. 153-163.
- [5] Maltbaek, J. C., 1964 September 'Classical beam method for the prediction of vibration characteristics of machine tool structure' Int.Machine Tool Design Research Conf. proceedings 5 pp 23-36.
- [6] Taylor S. and S.A. Tobias, 'Lumped-constants method for the prediction of the vibration characteristics of machine tool structures', Proc. 5th Int. M.T.D.R., Conf., pp.01-015, 1964
- [7] Badawi, M.W. & Thornley, R.H., 1965 'Comparison of static and dynamic characteristics of losed box section beams with and without core holes and for some other beam configurations' Int. J. Mach.Tool Des. Res. Vol.6, pp. 199-206.
- [8] Ganesan N. Ramamurti V. and Rao B.V.A., "Torsional behavior of machine tool columns", Int. J. M.T.D.R., Vol.14, pp. 219- 231, 1974.
- [9] Cowley, A. and Fawcett, M.A. "The analysis of a Machine Tool Structure by Computing Techniques" Proc.8th Int. M.T.D.R. Conf., pp. 119-138, 1967.
- [10] Yoshimura Masataka "Analysis and optimization of structural dynamics of machine tools by a synthesis of dynamic rigidity program system", Int. M.T.D.R. Conf. pp.209-215, 19 75.
- [11] Reddy, C.P. and Rao, S.S "Dynamic Analysis of Machine Tool Structures, Journal of Engineering for Industry, Transaction of ASME, 1977, pp-882-888.
- [12] Dube J.N., 'computer aided design of machine tool structure with model technique', Int. J.computers and structures Vol.28, No. 3, pp. 345-352, 1988.
- [13] Yoshimura M. and T. Hoshi, 'Computer Approach to Dynamically Optimum design of machine tool structures', 12th Int. M.T.D.R.Conf. pp. 439-446, 1971.

- [14] Ramana G.V. and Rao S.S., "Optimum design of plano- milling machine structure using finite element analysis", *Int. J. of computers and structures*, Vol.18, No.2, pp. 247-253, 1984.
- [15] K. Mao et al, Stiffness influential factors-based dynamic modeling and its parameter identification method of fixed joints in machine tools, *International Journal of Machine Tools & Manufacture* 50 (2010) 156–164
- [16] Bath, K. J "Finite Element Procedures", Prentice-Hall 1996
- [17] ASYS Inc. (2005), ANSYS Advanced Analysis Techniques Guide.
- [18] Koenigsberger, F. and Tlustý, "Machine Tool Structures" Vol. I, Pergamon, 1970.
- [19] Mustafizur Rahman et al, Non-Conventional Materials for Machine Tool Structures *JSME international journal*, Vol. 44 No. 1 2001
- [20] Migbar Assefa "The Effect of Tapers, Apertures and Ribs on the Stiffness of Machine Tool Column Using Finite Element Method" *Journal of 15th Annual Conference, Ethiopian Society of Mechanical Engineers Journal* Vol. VIII No.I, October 2010.
- [21] Migbar Assefa, "Finite Element Based Dynamic Analysis of Machine Tool Column", *International Journal of Engineering Science, Nigeria*, Vol. 2, No. 4, 2010, pp 62-70
- [22] Hinduja, S. and A. Cowley, 'The finite element method applied to the deformation analysis of thin walled columns'. *Proc. 12th Int. J. M.T.D.R.*, pp.455-477, 1971.
- [23] Harris, C., 2002, "Shock and Vibration Handbook", McGraw-Hill: New York, 5th Edn. ISBN 0-07-137081-1
- [24] Cheng Zheng-ding and Xiong Huan-guo 1981 'finite element study of dynamic characteristics of main components of machine tools' applied mathematics and mechanics English edition Vol.2.