

Bandwidth Control Using Reconfigurable Antenna Elements

Sudhina H. K, Ravi M. Yadahalli, N. M. Shetti

II. RECONFIGURABLE ANTENNA

A. Operation

The radiation pattern and functionality of an antenna are related to the current distribution on its surface. Any slight change in the geometrical configuration of the structure will create new current paths and new radiation edges, which give the antenna new resonances and operational functionality [1], [2].

A lot of reconfigurable antennas make use of switches [2], rotating parts and many other components to vary the current distribution over the physical surface of the antenna. This constitutes a transformation or a translation from a physical activity into an electrical behavior change

B. The Goal of Reconfigurable Antennas Is to

1. Radiate at pre-determined frequencies on demand
2. Change the polarization
3. Change the radiation patterns, on demand

It is also expected that these antennas, can be reconfigured remotely without rebuilding the antenna or the platform on which it is placed.

C. Reconfigurable Elements

Reconfigurable elements represent antennas that radiate with one or few primary radiating elements. That primary element is reconfigured via switches or some other variable element to provide parameter control.

III. TYPES OF RECONFIGURABLE ANTENNAS

A. Reconfigurable Slot Antenna

The reconfigurable slot antenna [3] is an electronically tunable planar VHF slot antenna. It consists of a microstrip fed resonant slot structure loaded with a series of PIN diode switches. The resonant frequency of operation is selected, by varying the length of the radiating slot and thus changing its electrical length. The length of the slot is altered by biasing the PIN diode switches along the slot length. It is capable of operating at four different frequencies in the band from 500 to 900 MHz.

B. MEMS Reconfigurable Vee (Vee Dipole) Antenna

The reconfigurable vee dipole antenna [4]-[6] uses MEMS actuators to vary the pitch angle of a Vee dipole antenna to change the beam type. The reconfigurable tapered slot array achieves beam steering via a different but also with MEMS switches. It consists of an array of tapered slot antennas whose slot lengths can be changed by altering the state of MEMS switches placed along the length of each slot. The MEMS

Abstract—Reconfigurable antennas represent a recent innovation in antenna design that changes from classical fixed-form, fixed function antennas to modifiable structures that can be adapted to fit the requirements of a time varying system.

The ability to control the operating band of an antenna system can have many useful applications. Systems that operate in an acquire-and-track configuration would see a benefit from active bandwidth control. In such systems a wide band search mode is first employed to find a desired signal then a narrow band track mode is used to follow only that signal. Utilizing active antenna bandwidth control, a single antenna would function for both the wide band and narrow band configurations providing the rejection of unwanted signals with the antenna hardware. This ability to move a portion of the RF filtering out of the receiver and onto the antenna itself will also aid in reducing the complexity of the often expensive RF processing subsystems.

Keywords—Designing methods, MEMS, stack, reconfigurable elements.

I. INTRODUCTION

THE recent advent of microelectromechanical system (MEMS) components into microwave and millimeter wave regimes has opened new and novel avenues of antenna technology development. High quality, miniature RF switches provide the antenna designer with a new tool for creating dynamic radiating structures. The antenna is beginning to be seen as a component or sub-system that may be intelligently altered in-situ to meet operational goals.

This paper discusses a comprehensive investigation of reconfigurable antennas with a primary focus on antenna bandwidth control. The problem motivation is to investigate the use of new RF switch technology to actively and intelligently change the operating bandwidth of an antenna. The key design objectives that are considered in the bandwidth control design problem include: high degree of bandwidth control, minimization of active switching components and an overall reduction in antenna design complexity.

Sudhina H.K is with the Rural engineering College as Associate Prof. & Head, Dept of E & CE. R.E.C Hukoti, Gadag Karnataka, India (phone: 91-8749-00-22-00; fax: 08372-289427; e-mail: sudhinahk@gmail.com).

Dr. Ravi M.Yadahalli is with PESITM as a Prof. & Head. of E & C, Shimoga, Karnataka, India (e-mail: raviyadahalli@yahoo.com).

Dr. N. M. Shetti is with S.D. M. College, Ujire, India as Professor and Head, Dept. of Physics, India (phone: 91-9972262356; e-mail: nmshetti2003@yahoo.co.in).

reconfigurable Vee antenna is a printed antenna that uses dynamic actuators to alter the radiation characteristics of the antenna. Fig. 1 shows the geometry of the reconfigurable Vee antenna. The antenna uses MEMS actuators to alter geometry of the Vee dipole. Push-pull actuators connected to the dipole arms enable reconfiguration of the Vee pitch angle. Each arm of the Vee is independently controlled using actuators, Symmetrical movements of the Vee actuators result in a widening and narrowing of the angle, and thus widens and narrows the main beam. The main beam may be steered broadside by moving each Vee actuator by different distances.

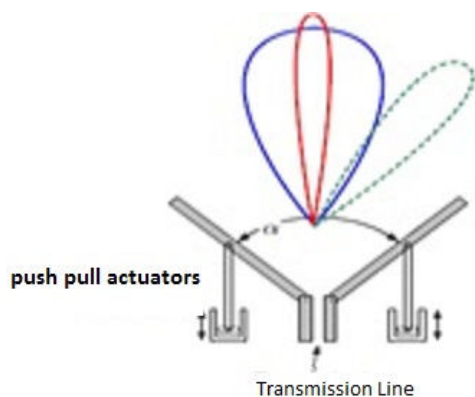

Fig. 1 Reconfigurable vee (vee dipole) antenna

C. Reconfigurable Dime and Q-Dime Antennas

The dime antenna [7]-[9] & it's constituted of dime elements are broadband multilayered stacked circular patches. Fig. 2 shows the basic geometry of the dime antenna.

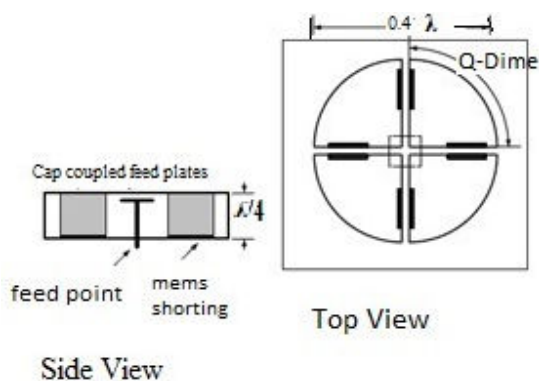

Fig. 2 Geometry of the proximity coupled reconfigurable dime antenna composed of four quarter-dime stacked patch antennas

The dime antenna is constructed as either a single monolithic element or as combination of four quarter dime (q-dime) elements. The antennas are electrically small (radius $< 0.2 \lambda$ & height $< 0.5 \lambda$) & volumetric in nature to achieve the size reduction. Broadband operation is accomplished by creating two degenerate modes via two cylindrical radiating slots in the patch structures.

D. Reconfigurable Leaky Mode Patch

This antenna [10], [11] is a combination of normal microstrip patch antenna and a leaky-wave antenna. Leaky-

wave radiation is facilitated by the presence of higher order modes on microstrip structures [12]. The antenna is shown in Fig. 3 and consists of a high-order mode launcher connected to a length of X-band leaky mode microstrip antenna. The mode launcher is composed of a microstrip impedance Transformer, 180o phase shifter and an even-mode suppressor. The leaky-mode antenna is then connected via MEMS switches to a conventional C-band microstrip patch antenna. When the MEMS switches are deactivated the antenna operates as a conventional patch antenna. Activating the switches causes the patch structure to become part of the leaky-mode structure and the antenna radiates as a leaky-mode antenna.

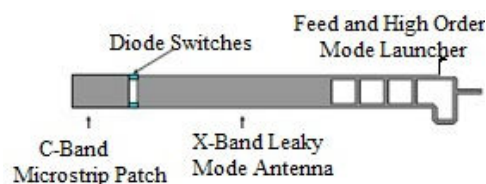

Fig. 3 The reconfigurable leaky mode patch antenna

E. MEMS Mechanical Beam Steering

The antenna system [13] has a V-band radiating patch antenna element. It uses a MEMS fabricated element platform with two degrees of rotational freedom to facilitate the main beam scanning. The MEMS antenna system is capable of scanning the main beam over 60degree with no measured scan loss

F. Stacked Reconfigurable Bowtie

The stacked reconfigurable bowtie [14] antenna consists of a dual layer arrangement of unequal size balanced microstrip bowtie elements. Fig. 4 shows the geometry of the stacked reconfigurable bowtie antenna. The individual bow ties are situated on mixed dielectric layers above a ground plane and the bowtie geometries are designed for 3.1 GHz and 8 GHz operation. Each bowtie layer is constructed on top of a mixed layer dielectric consisting of a thick polymer layer ($\epsilon_r \approx 3.0$) over a thin foam layer ($\epsilon_r \approx 1.0$). This layered dielectric arrangement provides both upper and lower operating bands with nearly 25% bandwidth. The smaller high-frequency bowtie layer is stacked on top of the larger low-frequency bowtie layer. The low-frequency antenna acts as a virtual ground plane for the high frequency antenna when the antenna is operating in the high-frequency mode. Several sets of MEMS switches are present under the ground plane and control the antenna band selection. A set of MEMS switches connects each of the bowtie feeds to the main antenna feed while an additional set of switches connects the bowtie feeds to the ground plane.

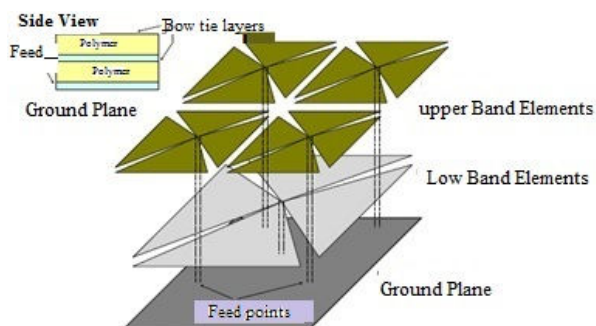

Fig. 4 The reconfigurable stacked bowtie antenna

The upper bowtie is activated by closing the appropriate set of switches and enabling the high frequency feeds. The lower bow ties are then grounded via the low-frequency MEMS switches and the larger bow ties act as a ground plane for the high-frequency elements. Conversely, in the low-frequency mode the lower elements are activated by closing the appropriate set of switches and enabling the low-frequency feeds. The upper bow ties are then disabled by disconnecting the MEMS switches for the high-frequency feeds. In this low-frequency configuration, the upper bow ties act as floating parasitic radiators for the lower elements and increase the operating bandwidth of the lower elements.

G. Reconfigurable Patch

The patch [15] uses a conventional microstrip patch antenna with the addition of two MEMS controllable shorting elements. Fig. 5 illustrates the geometry of the reconfigurable patch antenna. The antenna is fed through a conventional microstrip line. The MEMS switches are positioned at the far end of the microstrip patch. The patch operates at its nominal frequency when the MEMS switches are in the off state. As with other rectangular microstrip patches, frequency of operation is determined by the length L , the edge parallel to the microstrip feed. When the MEMS actuators are turned to the on state, they add a capacitance in shunt with the input impedance of the patch. This added capacitance has the effect of lowering the resonant frequency of the antenna.

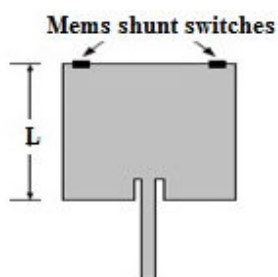

Fig. 5 The reconfigurable microstrip patch antenna

H. Reconfigurable Arrays

Antenna array scan employ reconfigurable design aspects in several methods. Dynamic reconfigurable elements can be used instead of conventional fixed antennas as the array elements. Or the array can use conventional fixed elements

and the feed section phase-controllers might employ reconfigurable elements.

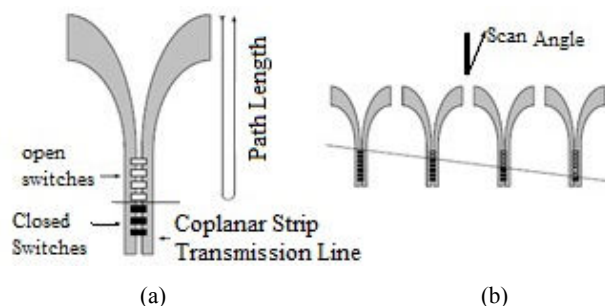

Fig. 6 The reconfigurable flared notch array element with time-delay beam steering

The flared notch antennas [3], [15] have MEMS switches placed along the notch feed section that allows the length of the feed section to be changed. This alteration of feed length introduces a time delay in the received energy. The time delay in the individual array elements allows the array to be electromechanically steered. Fig. 6 illustrates the antenna. Fig. 6 (a) shows the array element with MEMS switches for phase control and Fig. 6 (b) shows how these elements are combined in the array to perform beam scanning.

IV. RECONFIGURABLE ANTENNA METHODOLOGIES

Classical non-reconfigurable design methods have dominated antenna engineering for the majority of antenna design history. To make the transformation from fixed element operation to reconfigurable antenna design requires a suitable conversion in design methodology. The short existence of reconfigurable has produced two primary design methods: total geometry morphing and matching network morphing.

Total geometry morphing represents the most structurally complicated of the methods. It is implemented through a large array of switchable sub-elements which are combined to form the desired radiating structure. Matching network morphing is the simplest of the methods and modifies only the feed structure or impedance matching network of the antenna while the radiating structure remains constant. The smart geometry reconfiguration method lies between the other two in its structural implementation complexity. It modifies only critical parameters of the antenna radiating structure to achieve the desired range of reconfigurable control.

A. Total Geometry Morphing Method

The total geometry morphing method achieves reconfigurable operation by switching a large array of interconnected sub-elements. The sub-elements are connected together via RF switches and are typically less than $\lambda/20$ in size. Because the sub-elements are much less than a wavelength in size they do not form efficient radiating elements individually. However, switching together multiple adjacent sub-elements results in an aggregate structure that forms the desired radiator. This sub-element arraying allows considerable flexibility in forming the radiator. The geometry

of the aggregate radiating structure can take a wide variety of forms depending on the desired application. The reconfigurable antennas designed via this method are often referred to in the literature as distributed radiators because the total radiating structure is distributed over many smaller structures.

Fig. 7 illustrates the concept of the total geometry morphing method. The example is a reconfigurable microstrip patch antenna consisting of a large grid of switched microstrip sub-patches that are available on the dielectric substrate. These sub-patches do not represent individual microstrip patch antennas themselves but act as actively reconfigurable conducting structures.

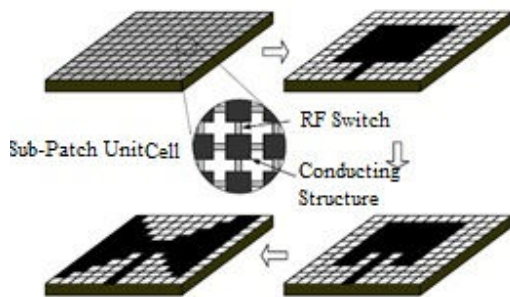

Fig. 7 The total geometry morphing method of reconfigurable antenna design

The detailed blow-up in Fig. 7 shows a single functional unit cell for the composite antenna. These unit cells illustrate the concept of the sub-patch conducting structure. Each unit cell consists of a small conducting patch of metal and four RF micro switches. The switches provide the RF conduction path to the nearest neighboring unit cell. The composite antenna is then constructed by activating the necessary switches to form then antenna. In this example the structure is first configured to form a conventional rectangular microstrip patch antenna. Next, several of the sub-patches along the length of the microstrip feed are switched to the off state. This moves the effective feed point for the patch antenna closer to the center of the patch and alters the input impedance of the patch. Finally, the unit cells are configured to form a bow-tie patch antenna which has different radiation characteristics than the rectangular patch.

The total geometry morphing method has the obvious advantage of providing a large amount of antenna reconfigurability. The array of sub-elements provides a large level of flexibility in composing the aggregate antenna. Because of the flexibility in configuring the antenna, a wide range of control over many antenna characteristics is offered by employing this method. Thus, a single reconfigurable platform could be used for a large number of applications. System operation over multiple frequency bands, with variable radiation pattern characteristics and selective polarization is possible with a single reconfigurable platform. Likewise, the layout of the sub-element array pattern is not limited to two dimensional planar microstrip geometries. Surface conformal

and three dimensional geometries also represent viable configurations.

B. Matching Network Morphing Method

The matching network morphing method represents the simplest of the three techniques for achieving reconfigurable antenna operation. In this method, the actual radiating structure remains constant and only the feed or impedance matching section of the antenna is reconfigured. Like the total geometry method, this method is often employed with microstrip geometries because of the relative ease in placing RF switches on planar structures. In the case of microstrip feed lines, there are typically 10 or more sub elements in the transverse direction across the width of the microstrip line for adequate parameter control. They are on the order of $\lambda/20$ in length along the longitudinal direction.

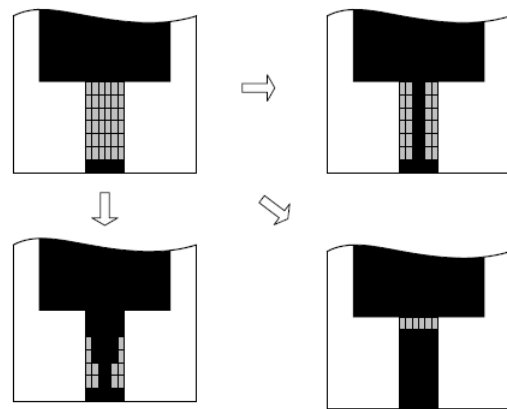

Fig. 8 Microstrip feed configurations for impedance matching of reconfigurable antenna design

Fig. 8 illustrates one implementation of the matching network morphing method. In this example a microstrip patch antenna is edge fed by a reconfigurable microstrip line. The reconfigurable microstrip line consists of a small array of switchable microstrip sub-elements. Each of these sub-elements may be switched on or off, by activating one of the miniature RF switches that forms the interconnections between the sub-elements and compose the overall microstrip structure. The width and length of the feed line is altered to change the impedance of the microstrip. The grey boxes represent inactive sub-elements and the block boxes represent active sub-elements. The top left configuration in Fig. 8 shows the microstrip patch antenna and the available microstrip feed lattice. The top right sub-element arrangement shows the feed configured as a narrow microstrip line having characteristic impedance. The patch antenna operates in a radiation mode that is specified by this feed configuration.

The two arrangements in Fig. 8 show the microstrip feed line configured in two other possible formations. These variations in feed impedance then excite different radiation modes in the microstrip patch antenna.

The matching network morphing technique carries the distinct advantage of being extremely simple to implement in practice. The only component of the antenna that is changed is

the feed network and thus the complexity of the design is minimized.

As a result, the number of physical switching components is kept to a minimum and switch reliability becomes less of an issue.

C. Mapping Reconfigurable Antennas Using Graphs

A graph can be defined as the collection of vertices connected together with lines called edges. A simple labeled graph over an alphabet Σ is represented by $G = (V, E)$ where V is a set of vertices and E is a set of pairs or edges from V . There are many types of graphs but here we are only interested in studying undirected graphs. Vertices may represent physical entities and edges between them in the graph represent the presence of a function resulting from connecting these entities. If one is proposing a set of guidelines for antenna design, then a possible rule may be to create an edge between two vertices whenever their physical connection results in a meaningful antenna function. Edges may have weights associated with them to represent costs or benefits that are to be minimized or maximized. The weight of a path is defined as the sum of the weights of its constituent edges.

D. Smart Geometry Reconfiguration

The final identified method of reconfigurable antenna design is smart geometry reconfiguration. Falling between total geometry morphing and the matching network morphing method. In both the amount of achievable parameter control and system Complexity is considered, this method modifies only critical parameters of the antenna radiating structure to achieve the desired reconfigurable performance. It can be implemented with considerably fewer control elements than the total geometry method and thus has the advantage of reduced design complexity. However, with a thorough understanding of the underlying antenna design and careful design consideration it can yield a high level of reconfigurability and antenna parameter control. The primary disadvantage of this method is that the underlying physics of the particular antenna must be known in order to take advantage of minor geometry modifications to achieve the reconfigurable goal. Additionally, the amount of reconfigurability is ultimately limited by the electrical characteristics of the antenna geometry.

REFERENCES

- [1] S. Licul, Time-domain antenna characterization and design, Ph.D. dissertation, Virginia Tech, Blacksburg, VA, 2004.
- [2] J. H. Schaffner, D. F. Sievenpiper, R. Y. Loo, J. L. Lee, and S. W. Livingston, A wideband beam switching antenna using RF MEMS switches," HRL Laboratories, Malibu, CA, USA, Tech. Rep., 2001.
- [3] D. Peroulis, K. Sarabandi, and L. Katehi, A planar VHF reconfigurable slot antenna," in Antennas and Propagation Society, 2001 IEEE International Symposium, vol. 1 Boston, MA, July 2001, pp. 154 - 157.
- [4] J.C. Chiao, MEMS RF devices for antenna applications," in Microwave Conference, 2000 Asia-Pacific. Sydney: IEEE, December 2000, pp. 895-898.
- [5] J.C. Chiao, Y. Fu, I. M. Chio, M. DeLisio, and L.Y. Lin, MEMS reconfigurable Vee antenna," in Microwave Symposium Digest, 1999 IEEE MTT-S International, M. Matloubian and E. Ponti, Eds., vol. 4. IEEE, June 1999, pp. 1515-1518.
- [6] J.C. Chiao, Y. Fu, I. M. Chio, M. DeLisio, and L.Y. Lin, MEMS reconfigurable Vee antenna," in Microwave Symposium Digest, 1999 IEEE MTT-S International, M. Matloubian and E. Ponti, Eds., vol. 4. IEEE, June 1999, pp. 463-466
- [7] B. Cetiner, L. Jofre, and F. D. Flaviis, Reconfigurable miniature multielement antenna for wireless networking," in IEEE Radio and Wireless Conference, 2001. RAWCON 2001, August 2001, pp. 203-206.
- [8] L. Jofre, B. Cetiner, and F. D. Flaviis, Miniature multi-element antenna for wireless communications," IEEE Transactions on Antennas and Propagation, May 2002, pp. 658-669.
- [9] B. Cetiner, L. Jofre, G. Li, and F. de Flaviis, A packaged reconfigurable multielement antenna for wireless networking," in 2001 Asian-Pacific Microwave Conference. APMC 2001, vol. 2, Taipei, Taiwan, December 2001, pp. 705-708.
- [10] B. Chang, Y. Qian, and T. Itoh, A reconfigurable leaky mode/patch antenna controlled by pin diode switches," in IEEE Antennas and Propagation Society International Symposium, 1999, vol. 4, Orlando, FL, July 1999, pp. 2694-2697.
- [11] Y. Qian, B. Chang, M. Chang, and T. Itoh, Reconfigurable leaky-mode multifunction patch antenna structure, Electronic Letters, vol. 35, no. 2, January 1999, pp. 104-105.
- [12] C.K.C. Tzuang, Leaky mode perspective an printed antenna, Proceedings of National Science Council ROC(A), vol. 23, no. 4, 1999, pp. 544-549.
- [13] C.W. Baek, S. Song, C. Cheon, Y.K. Kim, and Y. Kwon, 2-D mechanical beam steering antenna fabricated using MEMS technology, in IEEE MTT-S International Microwave Symposium Digest, 2001, Phoenix, AZ, May 2001, pp. 211-214.
- [14] J. Bernhard, R. Wang, R. Clark, and P. Mayes, Stacked reconfigurable antenna elements for space-based radar applications, in IEEE Antennas and Propagation Society International Symposium, 2001, vol. 1, Boston, MA, July 2001, pp. 158-161.
- [15] R. Simons, D. Chun, and L. Katehi, Reconfigurable array antenna using microelectromechanical systems (MEMS) actuators, in IEEE International Symposium.