

Numerical Investigation of Indoor Air Quality and Thermal Comfort in a Ventilated Room

Ramy H. Mohammed

Abstract—Understanding the behavior of airflow in a room is essential for building designers to provide the most efficient design of ventilation system, and having acceptable indoor air quality. This trend is the motive to solve the relationship between airflow parameters and thermal comfort. This paper investigates airflow characteristics, indoor air quality (IAQ), and the thermal comfort (TC) in a ventilated room with a displacement ventilation system using three dimensional CFD code [AirPak 2.0.6]. After validation of the code, a numerical study is executed for a typical room with dimensions of 5m by 3m by 3m height according to a variety of supply air velocities, supply air temperature and supply air relative humidity. The finite volume method and the indoor zero equation turbulence models are employed for solving the governing equations numerically. The temperature field and the mean age of air (MAA) in the modeled room for a displacement ventilation system are determined according to a variety of the above parameters. The variable air volume (VAV) systems with different supply air velocity are applicable to control room air temperature for a displacement ventilation system.

Keywords—Displacement ventilation, AirPak, Indoor zero equation, MAA.

I. INTRODUCTION

NOWADAYS, the majority of people spend up to 90% of their time indoors. Knowledge and prediction of indoor climate conditions are important for optimizing indoor climate and indoor air quality, and it is also important for energy conservation [1]-[10]. Indoor air quality and thermal comfort are two important aspects of indoor environmental quality that receive considerable attention [11].

Displacement ventilation has been applied mainly in more countries and spreading worldwide. It causes slow upward airflow in a room with bottom wall outlets. Supply air is introduced to the room at a low velocity and at a temperature slightly below the desired room temperature. Over 40% of US energy consumption is related to the provision of adequate heating, cooling and ventilation for buildings. So, the study of thermal comfort is very important because it is correlated not only with occupants' comfort, but also with energy consumption [12].

Understanding the behavior of airflow in a room is essential for building designers to provide the most efficient design of ventilation system, and having acceptable indoor air quality. This trend is the motive to solve the relationship between airflow parameters and thermal comfort. This paper investigates airflow characteristics, indoor air quality (IAQ), and the thermal comfort (TC) in a ventilated room with a

displacement ventilation system using three dimensional CFD code [AirPak 2.0.6]. After validation of the code, a numerical study is executed for a typical room with dimensions of 5m by 3m by 3m height according to a variety of supply air velocities, supply air temperature and supply air relative humidity. The finite volume method and the indoor zero equation turbulence models are employed for solving the governing equations numerically. The temperature field and the mean age of air (MAA) in the modeled room for a displacement ventilation system are determined according to a variety of the above parameters. The variable air volume (VAV) systems with different supply air velocity are applicable to control room air temperature for a displacement ventilation system.

From the view point of HVAC design as present in ASHRAE Applications Handbook [13] that recommends general guidelines for an operating room that its temperature should be held in the range of (20–24°C), relative humidity should be from 50% to 60%, positive air pressure should be maintained, and all air exhausted with no recirculation is preferred. ISO7730-1994 presents moderate thermal environments and recommends that the vertical air temperature difference (VATD) from the ankle level 0.1m to the height of 1.1m which is representative for the breathing zone of a sitting person has been used to determine the local thermal discomfort. The maximum temperature difference between ankle level and head one must be below 3°C [14]-[16].

The mean age of air (MAA) is generally defined as the average time for air to travel from a supply inlet area to any location in a ventilated room [17]-[19]. The mean age of air is one of the most important parameters that describe the ventilation efficiency in a space. The age of air concept assumes that the age of air at the inlet area is equal to zero (100% fresh). It is obvious that the high values of the mean age of air (MAA) mean that part of the air circulates for a long time inside the room. So the values of the mean age of air reflect the efficiency of ventilation system [20].

In the past years, Spitler [21] studied experimentally the effect of the inlet velocity on air distribution in a full scale unoccupied ventilated room that has the dimension of 5m long, 3m wide, and 3m high. The supply and exhaust outlets are each 0.333m wide and 1.0m high. Nielsen [22] presented an attractive alternative to the experimental methodology to determine indoor airflow characteristics. Computational fluid dynamics opened a route to numerically predict the indoor climate on a detailed level with high flexibility in terms of configurations and boundary conditions. Baker et al. [23] studied the same Spitler's experimental room numerically

R. H. Mohammed is with the Zagazig University, CO 44519 Egypt (phone: 201114049331; e-mail: Rhamdy@zu.edu.eg).

using a finite element method, and Alfahaid [24] studied the effect of the inlet velocity and temperature, and compared his results with Spittler's and Baker's results for the same room. For specific air supply systems, Chen [25] and Niu [26] determined relations for the temperature distribution in the room as a function of the internal heat load and the ventilation rate for a range of simulated airflow patterns using CFD. Later, Peng [27] adopted a similar approach. All of these previous studies did not examine the effect of supply air relative humidity on the air distribution in the room.

Recent advances in computational fluid dynamics and computer power make it possible to accurately predict some features of airflow within ventilated spaces. The CFD method has been successfully applied for airflow analysis in room. However, it usually requires lots of meshes and consumes much time to get convergence for engineering problems. The main factors affecting the simulation speed are the method of describing inlet boundary conditions [28], turbulence model used [29], and the numerical method of solving the discrete equations [30]. Computational fluid dynamics technique is widely used to predict airflow in ventilated rooms. Especially for parametric studies, CFD is a useful scheme to save cost and time, compared to experimental methods. Recent computer technology encourages the utilization of CFD due to higher calculating performances. CFD requires iterating calculations and post processing techniques.

This study is dedicated to a three dimensional numerical analysis of a displacement ventilation system. To fill the lack in the previous studies, parametric simulations are carried out for a typical office room with a variety of supply air velocities, supply air temperature and supply air relative humidity. The main goal of this paper is to improve the knowledge of the indoor airflow distribution for displacement ventilation, and to study the temperature field, the velocity field, the relative humidity, and the mean age of air (MAA) in the room, and then it will be possible to optimize indoor air quality, thermal comfort and energy use during the design. On the other hand, this paper aims to validate that a displacement ventilation system achieves not only thermal comfort but also energy conservation.

II. NUMERICAL CFD MODEL

The CFD tools are being increasingly used in the industries concerned with fluid flow. Some programs have been developed for the HVAC industry as well. For this study, a commercial CFD code [AirPak 2.0.6] is used to predict flow and temperature field in the room with displacement ventilation system. The AirPak CFD tool from Fluent Inc. was used. The AirPak program is a customized version of the FLUENT program [31]. It lets the user accurately model airflow, heat transfer, and species transport equations. The program uses a new zero-equation indoor turbulence model that addresses the need for a simple but reliable turbulence model for room ventilation [32]. Moreover the program interface is user friendly and allows quick set up of the model and its specifications.

The governing equations are the incompressible

Navier-Stokes equations and the continuity equation in Cartesian coordinates. The Boussinesq hypothesis is used for the buoyancy force term. The steady-state calculations are carried out for all the cases.

Indoor airflow calculations use the Boussinesq approximation for thermal buoyancy [33]. The approximation takes air density as constant in the momentum terms and considers the buoyancy influence on air movement by the difference between the local air weight and the pressure gradient. With an eddy-viscosity model, the indoor airflow is described by the following time-averaged Navier-Stokes equations for the conservation of mass, momentum, energy, and species transport equation.

Continuity

$$\frac{\partial V_i}{\partial x_i} = 0 \quad (1)$$

where V_i = mean velocity component in x_i -direction; x_i = coordinate (for $i=1, 2, 3$, x_i corresponds to three perpendicular axes).

Momentum Equation

$$\frac{\partial \rho V_i}{\partial t} + \frac{\partial \rho V_i V_j}{\partial x_j} = -\frac{\partial P}{\partial x_i} + \frac{\partial}{\partial x_j} \left[\mu_{eff} \left(\frac{\partial V_i}{\partial x_j} + \frac{\partial V_j}{\partial x_i} \right) \right] + \rho \beta (t_o - t) g_i \quad (2)$$

where ρ = air density; V_j = velocity component in x_j -direction; P = pressure; μ_{eff} = effective dynamic viscosity; β = thermal expansion coefficient of air; t_o = temperature of a reference point; t = temperature; g_i = gravity acceleration in i -direction. The last term on the right side of (2) is the buoyancy term. The turbulent influences are lumped into the effective viscosity as the sum of the turbulent viscosity μ_t and laminar viscosity μ_l :

$$\mu_{eff} = \mu_t + \mu_l \quad (3)$$

In the Prandtl-Kolmogorov assumption, the turbulent viscosity is the product of turbulence kinetic energy, k , and turbulent macro scale, L , that is a proper length scale for turbulence interactions: $\mu_t = C_v \rho k^{1/2} L$ where $C_v = 0.5478$, an empirical constant.

Energy Equation

$$\frac{\partial \rho t}{\partial t} + \frac{\partial \rho V_j t}{\partial x_j} = \frac{\partial}{\partial x_j} \left[\Gamma_{T,eff} \left(\frac{\partial t}{\partial x_j} \right) \right] \quad (4)$$

where Γ_{eff} is effective turbulent diffusion coefficient for t , $\Gamma_{T,eff} = \mu_{eff} / Pr_{eff}$ where Pr_{eff} is effective Prandtl number.

The Concentration of Species Equation

$$\frac{\partial \rho C}{\partial t} + \frac{\partial \rho V_j C}{\partial x_j} = \frac{\partial}{\partial x_j} \left[\Gamma_{C,eff} \left(\frac{\partial C}{\partial x_j} \right) \right] + Sc \quad (5)$$

where C is species concentration; $\Gamma_{c,eff}$ is effective turbulent diffusion coefficient for C ; SC is source term of C . Similar method to the energy equation is used to determine the effective diffusive coefficient for species concentration $\Gamma_{C,eff} = \mu_{eff} / Sc_{eff}$ where effective Schmidt number, Sc_{eff} , is equal to 1.0.

Supply Air Velocity:

$$v = \frac{ACH \times Volume}{3600 \times A} \quad (6)$$

where ACH is air change per hour, A is inlet area ($A = 0.333 \times 1 \text{ m}^2$), and room volume is equal to 45 m^3 .

A. Code Validation

The accuracy of the CFD code is established through a validation process. This process involves comparison of predicted results from the CFD code with those obtained from previous numerical studies with same conditions. One case has been chosen from present study compared with the results taken from Baker's numerical study [22], and Alfahaid's numerical study [23] with the same parameters.

Before this comparison, different structured grids were used to establish the grid independence. Fig. 1 shows the vertical temperature distribution averaged over the horizontal plane for 2,237, 4,014, 41,598 and 58,559 grid sizes. In this graph, the results 41,598 and 58,559 are very close to one another and therefore the results obtained with 58,559 grid size can be considered to be grid independent. After grid independence, the numerical code was validated as illustrative in Fig. 2 which shows the comparison between Alfahaid's numerical study, Baker's numerical study, and the results obtained from the present model.

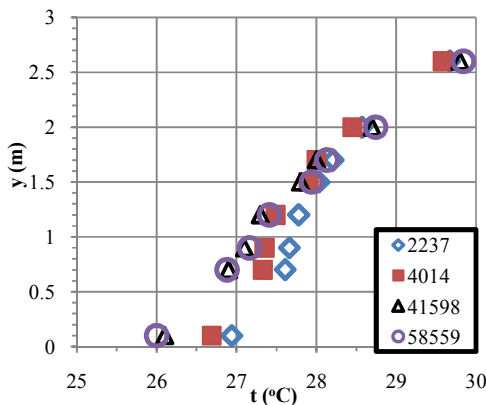

Fig. 1 Grid independence study for different grid size

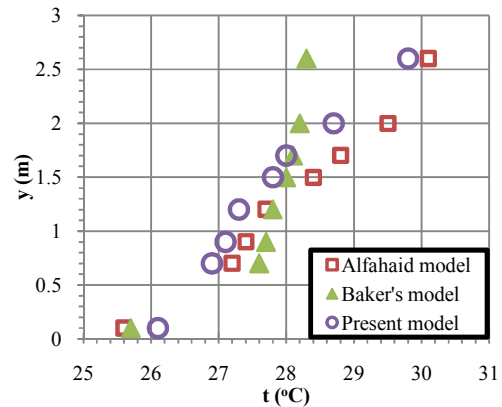

Fig. 2 Comparison between the present data, Baker's results [22], and Alfahaid's results [23]

III. ROOM MODEL FOR THE PRESENT STUDY

After validating the code with Alfahaid's results, and Baker's results, Spitler's room geometry was chosen to simulate a room to examine the effects of different environmental parameters on the phenomena of room displacement ventilation. Fig. 3 shows the room model employed in the present work that having the dimension of 5m long, 3m wide, and 3m high. The supply and outlet are each 0.333m wide and 1.0m high. There are no flow obstacles in the room interior. All interior walls and the ceiling are maintained at 31°C , and the floor is an adiabatic surface. All simulated cases are tabulated in Table I. Each case is studied for four different supply air temperatures.

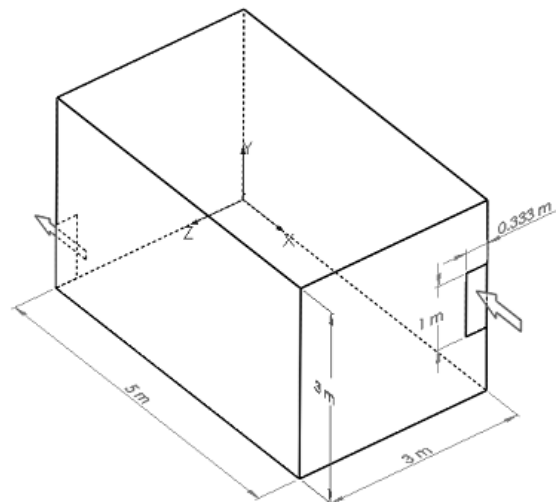

Fig. 3 Room model geometry employed in the present work

TABLE I
 SIMULATED CASES STUDIED IN THE PRESENT WORK

Case	V (m/s)	RH %	t (°C)
			19
A5R40	0.19	40	21
			23
			25
			19
A8R40	0.3	40	21
			23
			25
			19
A12R40	0.45	40	21
			23
			25
			19
A14R40	0.53	40	21
			23
			25
			19
A17R40	0.64	40	21
			23
			25
			19
A5R45	0.19	45	21
			23
			25
			19
A8R45	0.3	45	21
			23
			25
			19
A12R45	0.45	45	21
			23
			25
			19
A14R45	0.53	45	21
			23
			25
			19
A17R45	0.64	45	21
			23
			25
			19
A5R50	0.19	50	21
			23
			25
			19
A8R50	0.3	50	21
			23
			25
			19
A12R50	0.45	50	21
			23
			25
			19
A14R50	0.53	50	21
			23
			25
A17R50	0.64	50	19

			21
			23
			25
			19
A5R60	0.19	60	21
			23
			25
			19
A8R60	0.3	60	21
			23
			25
			19
A12R60	0.45	60	21
			23
			25
			19
A14R60	0.53	60	21
			23
			25
			19
A17R60	0.64	60	21
			23
			25

IV. RESULTS AND DISCUSSION

The numerical results obtained from the analysis of the velocity, the temperature and the relative humidity field, are presented as follows.

The velocity contours in different locations are shown in Figs. 4 and 5. It is shown that the velocity just above the floor that is near to the inlet is high and it decreases when we moving away the inlet. Therefore, the buoyancy force effect appears only near to the inlet and this effect can be neglected far from the inlet, and this effect appears also on temperature contours as shown in Figs. 6 and 7 and also in the relative humidity contours as shown in Figs. 8 and 9.

The values of the mean age of air at different location are shown in Figs. 10 and 11. It is shown that MAA is low in the lower zone so that, the lower zone is fresher than the upper zone. This means that the ventilation efficiency in the lower zone is higher than in upper zone. On the other hand, due to the supply location in the corner of the room (Fig. 3), air hits the wall since the moment it enters the room, this allows air to circulate away from the inlet which leads to increase the value of the mean age of air away from the inlet. Therefore, the ventilation efficiency decreases far from inlet especially in the upper corner above outlet where the value of the mean age of air is high in this area.

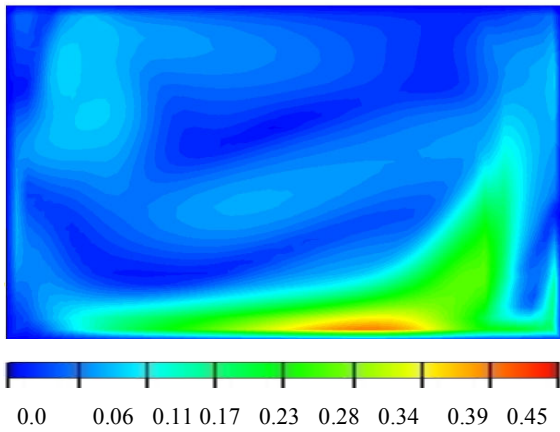

Fig. 4 Velocity contour on plane at $Z=0.75$ m for case A12R50 at $t_{in}=21^{\circ}\text{C}$

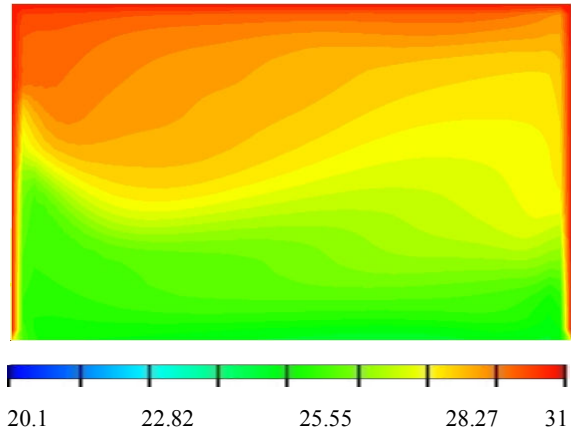

Fig. 7 Temperature contour on plane at $Z=1.5$ m for case A12R50 at $t_{in}=21^{\circ}\text{C}$

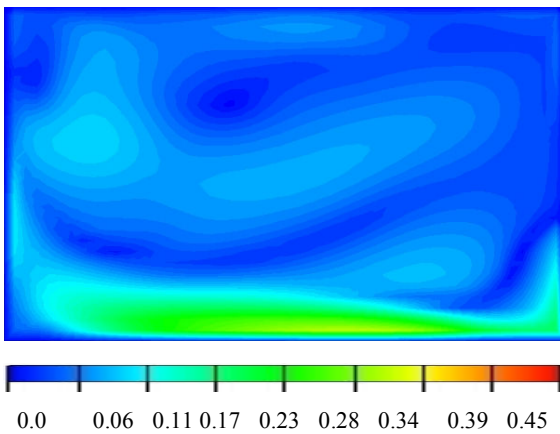

Fig. 5 Velocity contour on plane at $Z=1.5$ m for case A12R50 at $t_{in}=21^{\circ}\text{C}$

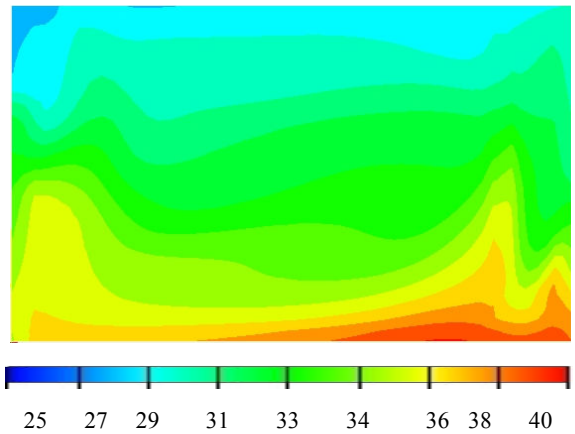

Fig. 8 Relative humidity on plane at $Z=0.75$ m for case A12R50 at $t_{in}=21^{\circ}\text{C}$

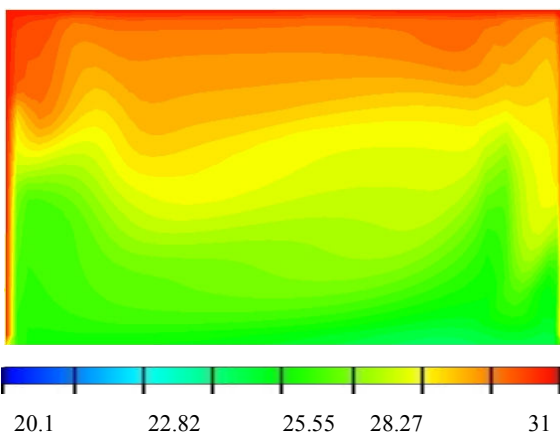

Fig. 6 Temperature contour on plane at $Z=0.75$ m for case A12R50 at $t_{in}=21^{\circ}\text{C}$

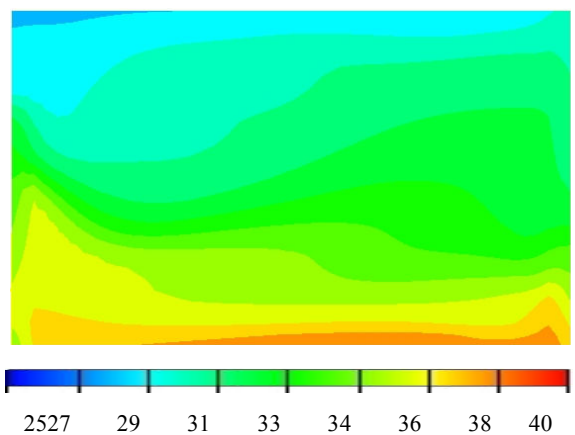

Fig. 9 Relative humidity on plane at $Z=1.5$ m for case A12R50 at $t_{in}=21^{\circ}\text{C}$

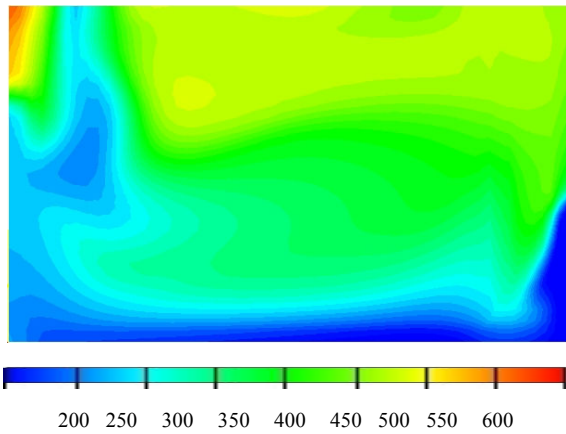

Fig. 10 Mean age of air on plane at $Z=0.75$ m for case A12R50 at $t_{in}=21^{\circ}\text{C}$

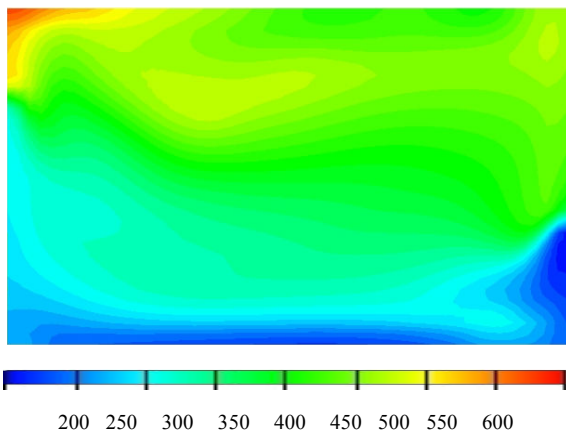

Fig. 11 Mean Age of Air on plane at $Z=1.5$ m for case A12R50 at $t_{in}=21^{\circ}\text{C}$

Fig. 12 shows the vertical air temperature differences (VATD) between the level of 0.1m and 1.1m above floor for different supply velocities. The supply air velocity of 0.188 m/s is not enough to satisfy requirements of ISO7730 for all temperature, however the velocity of 0.3 m/s is needed only for $t_{in}=21^{\circ}\text{C}$ to satisfy ISO7730 recommendation and more increasing the temperature and velocity are not effective. Therefore, it is possible to adapt a VAV system for displacement ventilation to save fan energy without reducing thermal comfort of the occupants.

For different inlet relative humidity as shown in Fig. 13, supply air velocity of 0.3 m/s is enough to satisfy ISO7730 recommendation for any inlet relative humidity; this means that any increase of inlet relative humidity does not affect thermal comfort for displacement ventilation from ISO7730 recommendation viewpoint as presented previously.

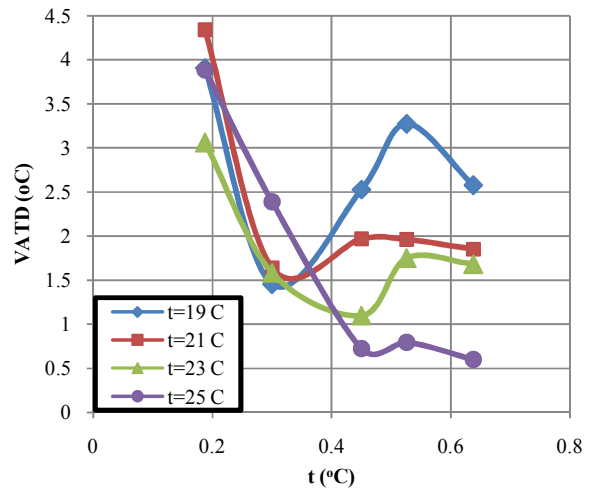

Fig. 12 Vertical air temperature difference between 0.1m and 1.1m above floor at $\text{RH}_{in}=50\%$

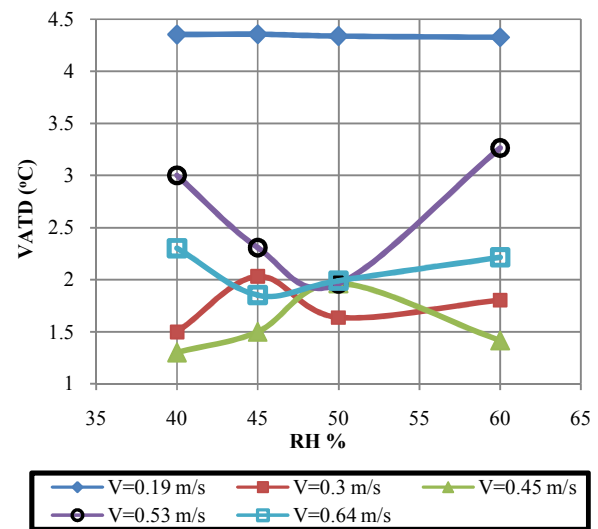

Fig. 13 Vertical air temperature differences between 0.1m and 1.1m above floor at $t_{in}=21^{\circ}\text{C}$

V. CONCLUSION REMARKS

- Buoyancy force has great effect on temperature and velocity field especially in case of low inlet temperature.
- Increasing the supply air velocity does not having any effect on the trend of the relative humidity profiles.
- The variation of the temperature profile for low inlet temperature cases was higher than for high inlet temperature cases.
- In the displacement ventilation system, the thermal comfort depends on the supply air temperature and the air velocity while the inlet relative humidity effect can be neglected.

- The relative humidity of the supply air should be 15% higher than the recommended value in the room in case of low inlet temperature, and 20% in case of high inlet temperature.
- Displacement ventilation system is expected to achieve not only thermal comfort in ventilated rooms but also energy saving of fan power.

REFERENCES

- [1] Cehlin M, Moshfegh B, Sandberg M. "Measurements of air temperatures close to a low velocity diffuser in displacement ventilation using infrared camera". *Energy and Buildings*; vol.34; p 687-98, 2002.
- [2] Cehlin M, Sandberg, M. "Monitoring of a low-velocity air jet using computed tomography". In: *Proceedings of the eight international conference on air distribution in rooms*; p 361-4, 2002.
- [3] Hassani V, Stetz M. "Application of infrared thermography to room air temperature measurements". *Proceedings ASHRAE Transactions*; Part 2, p. 1238-47, 1994.
- [4] Linden E, Todde V, Sandberg, M. "Indoor Low Speed Air Jet Flow: 3-dimensional Particle Streak Velocimetry". *Proceedings of the sixth international conference on air distribution in rooms*, vol.2; p. 56-76, 1998.
- [5] Müller D, Renz U. "A low cost particle streak tracking system (PST) and a new approach to three dimensional airflow velocity measurements". *Roomvent'98*, vol.2; p.593-600, 1998.
- [6] Price P, Fischer M, Gadgil A, Sextro R. "Algorithm for rapid gas concentration tomography". Lawrence Berkeley National Laboratory; LBNL Report 46236, 2000.
- [7] Todd L, Farhat S, Mottus K, Mihlan G. "Experimental evaluation of an environmental CAT scanning system for mapping chemicals in air in real-time". *Applied Occupational and Environmental Hygiene*, vol; 16, p.45-55, 2001.
- [8] Sun Y, Zhang Y. "An overview of room air motion measurement", technology and application. *HVAC & R Research*, vol; 13, p.929-50, 2007.
- [9] Sandberg M. "Whole-field measuring methods in ventilated rooms". *HVAC & R Research*, vol; 13, p.951-70, 2007.
- [10] Cehlin, M. Moshfegh, B. "Numerical modeling of a complex diffuser in a room with displacement ventilation". *Building and Environment*, vol; 45, p. 2240 – 2252, 2010.
- [11] Huizenga, C., Abbaszadeh, S., Zagreus L., and Arens, E. "Air quality and thermal comfort in office buildings: Results of a large indoor environmental quality survey". *Proceedings of Healthy Buildings*, June 4-8, University of Porto, Lisbon, p. 393-397, 2006.
- [12] Ye, X.J., Zhu. Z.P., Lian. Z.W, Liu. H.M, Li, C.Z., and Liu, Y.M. "Field study of a thermal environment and adaptive model in Shanghai". *Indoor Air*, vol 16, p. 320-326, 2006.
- [13] ASHRAE Handbook: Applications, American Society of Heating, Refrigerating and Air-Conditioning Engineers, Inc., Atlanta, GA, 2003.
- [14] Hashimoto, Y. "Numerical study on airflow of an office room with displacement ventilation system". Ninth international IBPSA conference, Montreal, Canada, 2005
- [15] ASHRAE standard 55-2004: ASHRAE thermal environmental conditions for human occupancy. Atlanta, GA, USA: American Society of Heating, Refrigerating and Air Conditioning Engineers; 2004.
- [16] ISO.ISO7730: moderate thermal environments determination of the PMV and PPD indices and specification of the conditions for thermal comfort. Geneva: International Organization for Standardization, 1994.
- [17] Sandberg, M. Sjöberg, M. "The use of moments for assessing air quality in ventilated rooms". *Building and Environment*, vol 18; p.181-197, 1983.
- [18] Federspiel, C.C. "Air change effectiveness: theory and calculation methods". *Indoor Air*, vol 9; p. 47-56, 1999.
- [19] Vivian C, Pierre-Sylvain M. "Computational fluid dynamics (CFD) modeling of local mean age of air Distribution in forced-ventilation food plants". *Journal of Food Engineering*, vol 90; p. 90-10, 2009.
- [20] Simons, M.W., Waters, J.R. "Ventilation effectiveness parameters resulting from mechanical ventilation with recirculation". *International Journal of ventilation* 1(2), 119-126, 2002.
- [21] Spitler, J. D. "An Experimental Investigation of Airflow and Convective Transfer in Enclosures Having Large Ventilative Flow Rates". Ph.D. Thesis, University of Illinois at Urbana-Champaign, Urbana, Illinois, USA, 1990.
- [22] Nielsen, P.V., "Flow in Air Conditioned Rooms". Ph.D. Thesis, Nordberg Denmark, 1974.
- [23] Baker, A.J., Williams, P.T. and Kelso, R.M., "Numerical Calculation of Room Air Motion - part 1: Math, Physics and CFD Modeling," *ASHRAE Transactions*. Vol.100; Part1, p.514-530.
- [24] Ahmed f. Alfahaid, "Effects of ventilation on human Thermal comfort in rooms", Ph.D. Thesis, Old Dominion University, December 2000.
- [25] Chen, Q. "Indoor Airflow. Air Quality and Energy Consumption of Buildings", Ph.D. Thesis, Delft University of Technology, Delft, the Netherlands, 1988.
- [26] Niu, J. "Modeling of Cooled-Ceiling Air Conditioning Systems". Ph.D. Thesis, Delft University of Technology, Delft, Netherlands, 1994.
- [27] Peng, X. "Modeling of Indoor Thermal Conditions for Comfort Control in Buildings". Ph.D. Thesis, Delft University of Technology, Delft, the Netherlands, 1996.
- [28] Nielsen, P.V. "Description of supply openings in numerical models for room air distribution". *ASHRAE Transactions*, Vol. 98; pp. 963-71, 1992.
- [29] Weiran, X. "New turbulence models for indoor airflow simulation". Ph.D.thesis, Massachusetts Institute of Technology, USA, 1998.
- [30] Chaouun, L. "Multi grid method and application in computational fluid dynamics". Beijing: Tsinghua University Press, 1995.
- [31] Fluent Inc. 2001 "Getting Started with Airpak 2".
- [32] Chen, Q., Xu, W. "A zero-equation turbulence model for indoor airflow simulation". *Energy and Buildings*, Vol. 28; pp.137-144, 1998.
- [33] Etheridge D, Sandberg M. "Building ventilation, theory and measurement". England: John Wiley and Sons Ltd., 1996.