

Conceptual Synthesis of Multi-Source Renewable Energy Based Microgrid

Bakari M. M. Mwinyiwiwa, Mighanda J. Manyahi, Nicodemu Gregory, Alex L. Kyaruzi

Abstract—Microgrids are increasingly being considered to provide electricity for the expanding energy demand in the grid distribution network and grid isolated areas. However, the technical challenges associated with the operation and controls are immense. Management of dynamic power balances, power flow, and network voltage profiles imposes unique challenges in the context of microgrids. Stability of the microgrid during both grid-connected and islanded mode is considered as the major challenge during its operation. Traditional control methods have been employed are based on the assumption of linear loads. For instance the concept of PQ, voltage and frequency control through decoupled PQ are some of very useful when considering linear loads, but they fall short when considering nonlinear loads. The deficiency of traditional control methods of microgrid suggests that more research in the control of microgrids should be done. This research aims at introducing the dq technique concept into decoupled PQ for dynamic load demand control in inverter interfaced DG system operating as isolated LV microgrid. Decoupled PQ in exact mathematical formulation in dq frame is expected to accommodate all variations of the line parameters (resistance and inductance) and to relinquish forced relationship between the DG variables such as power, voltage and frequency in LV microgrids and allow for individual parameter control (frequency and line voltages). This concept is expected to address and achieve accurate control, improve microgrid stability and power quality at all load conditions.

Keywords—Decoupled PQ, microgrid, multisource, renewable energy, dq control.

I. INTRODUCTION

IN reality, every human being needs electricity which the most flexible form of energy. In that case electrical energy is central to concerns about sustainable development and poverty reduction. It affects practically all aspects of social and economic development, including livelihoods, water supply, agriculture, population growth, health, education, job creation and environmental concerns. Energy demand [1] in developing countries is growing rapidly. In order to meet this demand and at the same time to achieve sustainable development objectives on a global scale, conventional approaches to energy must be reoriented towards energy systems based on renewable energy and energy efficiency.

Worldwide, there is an increasing adoption of distributed generation (DG) in the form of Renewable Energy Sources (RES) [2] that form Minigrid and/or Microgrids. In this

direction, many issues related to economics, electrical system optimization and long-term viability have been focused and researched. The control of dc-dc regulator and inverter interfaced microgrid network that combines diversity of RES is the structure tackled by this research work. This research focuses on integration and control of RES microgrid where, architecture and controller for dc-dc converter and dc-ac inverter interfaced microgrid will be designed and developed. This particular focus on renewable energy research has been motivated by unavailability of electricity in grid isolated areas (mainly rural areas) while there are various electrification options from locally available and plenty diversity of unexploited RES.

The proposed microgrid architecture extends the traditional integration use of solar and wind generation systems to include other diversity of RES such as solar, mini/micro hydro generation, biofuel generation, biomass, biogas and oceanic (waves and tides) generation instead of fossil fuels to increase power density and maintaining reliability and sustainability. The proposed control is envisaged to allow the behavior aspects of a system to be considered simultaneously and thus improve stability and power quality of the micro/mini-grid for linear and nonlinear loads during grid connected and islanding operation modes. This paper presents a conceptual framework of integration of multiple renewable sources of stochastic nature for the purpose of supplying a minigrid which may also be coupled to the main grid.

II. RESEARCH PROBLEM AND OBJECTIVE OF THE RESEARCH WORK

As microgrids increasingly being considered to provide electricity for the expanding energy demand in the grid distribution network and grid isolated areas, the technical challenges associated with the operation and controls are immense [3], [4]. Management of dynamic power balances, power flow, and network voltage profiles imposes unique challenges in the context of Microgrids. Stability of the Microgrid during both grid-connected and islanded mode is considered to impose major control challenge during its o

In Microgrids, PQ has been used as traditional control method which is based on the assumption of mainly inductive line impedance. This assumption works fine in a grid connected Microgrid but proves failure in the case of isolated Microgrid because of poor X/R ratio [5]. Practically, isolated low voltage (LV) Microgrids are highly resistive and have dynamic power couplings whereby the control for instability presents an extra degree of technical challenge. Droop control employing PQ method which is being used for isolated

Bakari M. M. Mwinyiwiwa, Mighanda J. Manyahi, and Alex L. Kyaruzi are working in the Department of Electrical Engineering, University of Dar es Salaam, Tanzania (e-mail: bakari_mwinyiwiwa@yahoo.com).

Nicodemu Gregory is working in the Department of Electrical Engineering, Dar es Salaam Institute of Technology and a Ph.D. candidate at the University of Dar es Salaam, Tanzania.

Microgrid however, can lead to stability concerns because frequency and network voltage cannot be controlled independently as in conventional power system unless otherwise decoupled [6]-[8]. Nevertheless, the concept of PQ, voltage and frequency control through decoupled PQ are very useful when considering linear loads, but they fall short when considering nonlinear loads, hence present a room for more research in the control area of Microgrids.

This research intends to introduce the dq frame concept into decoupled PQ for dynamic load demand control in an inverter interfaced DG system operating as an isolated LV microgrid. Decoupled PQ in exact mathematical formulation in dq frame is expected to accommodate all variations in line parameters (resistance and inductance) and to relinquish forced relationship between the DG variables like power, voltage and frequency in LV microgrids and allow for individual parameter control (frequency and line voltage). This concept is expected to address and achieve accurate control, improve microgrid stability and power quality at all load conditions.

III. REVIEW OF SIMILAR PREVIOUS WORK AND THE EXISTING CHALLENGES

A. Introduction to Microgrids

Due to the high cost of fossil fuels, concerns regarding environmental effects and energy security and statutory regulations, renewable energy sources (RES) are experiencing a large growth [9]-[11]. RES are growing very fast as global modern DG capacity [3]. microgrid paradigm has been a promising efficient and effective use to interconnect distributed energy resources (DER), which influence the presence of grid connected and isolated microgrids. Conceptually, the isolated microgrid is like a scaled-DOWN version of a large-scale utility grid where the penetration of distributed generation in an isolated microgrid is by definition 100%.

Integration of microgrid can be termed into two scenarios;

- (i) One considers development trends and perspectives for widespread implementation of distributed generation based microgrid connected to the grid in either distribution or transmission levels. Sometimes they would have the ability to pull themselves off the grid and function in island mode when necessary to increase reliability for the local load.
- (ii) Second scenario is when microgrids operate as standalone power supply.

Various DG integration systems have been developed worldwide and some are found in [1], [9], [12]-[15]. All DG based RES has no permanent supply (power guarantee), but they can make an important contribution covering globally electricity demand in terms of annual power supplied. In operating terms, this means to cover demand, integration to form a MICROGRID and an additional power reserve (energy storage) must be available especially to stand alone systems [9].

B. DG Technologies

Microgrid combines diversity of distributed generating resources designed to operate in a unique technology that build an integrated system for better technical and economical operations [1], [10], [16], [17]. Such resources and technologies are photovoltaic systems (PV), High Concentration Photovoltaic (HCPV), Fuel Cells, wind turbines, Micro-turbines, mini-hydropower [9], [18]-[22]. Of all renewable energies, only wind energy plays an important role in covering about 1.3% of global electricity supplies.

In order to supply reliable, quality power, the microgrid must have mechanisms to regulate voltage and frequency in response to changes in customer loads and system disturbances as performance objectives. Diversities of technologies integration will lead to situations involving different equipment with different electric interfaces, opening clear paths for complex techniques to be implemented. However in many of the resources technology, power electronics devices dominate as the DG interface. Therefore all related objectives would be achieved in a higher degree as far as high efficient power electronics devices will be used and appropriate control techniques be developed.

Development of hybrid power systems based on RES represents one step further towards DG and influence researches on the application of power electronics as interface between various Renewable Energy Technologies (RET) [23]. Applications of power electronics in RET is very diverse specifically as interface between renewable sources (RS) and load and use of digital control schemes driven by software for better controlling efficiency, effectiveness and flexibility is encouraged [24]. With a large amount of digital load such as PCs the control dynamics of the interface must be fast in order to deliver sufficient power with high quality.

Power electronics industry has developed various families of power electronic converters often linked by power levels, switching devices, and topological origins. Each family of power converters has preferred modulation strategies associated with it that aim to optimize the circuit operation for the target criteria most appropriate for that family. Parameters such as switching frequency, distortion, losses, harmonic generation, and speed of response are typical of the issues which must be considered when developing modulation strategies for a particular family of converters. Standard power converter topology can be used to implement a new idea, such that power converter can be built to be multipurpose [25]-[28].

Traditionally, power grids are supplied by sources having rotating masses and these are regarded as essential for the inherent stability of the system. In contrast, microgrids are dominated by inverter interfaced DG units (e.g. fuel cell, solar PV arrays, microturbines, storages and wind turbines) that are inertia-less, but do offer a possibility of flexible operation. Inverter-based DG units tend to have faster dynamics, but smaller output impedance; therefore, it can quickly switch between grid-connected and islanded modes. However it is susceptible to a larger switching transient during transition. In general view, the specification of a power electronic interface used is subject to requirements related not only to DG itself

but also to its effects on the power-system operation, especially where the resource variability constitutes a significant part of the total system capacity.

C. Control Issues and Technical Challenges in Microgrids

Instability and power quality in microgrids is considered in terms of voltage and frequency variations due to variation of resources and dynamic load demand. In a good power quality network the power generated must be equal to the load demand at any particular point of time [4]. FACTS and D-STATCOM devices using PQ control scheme have suggested for reactive and active power control in order to alleviate instability problems in grid connected microgrids and droop control for isolated microgrid, employing traditional method for power control based on the assumption of mainly inductive line impedance [4], [6], [29], [30]. Artificial Intelligence (AI) algorithms have been among the efforts to find high accuracy for tuning controller parameters in order to improve the system control and stability [29], [31].

Integrating renewable energy sources into the main grid or microgrid to any considerable degree can expose the system to issues that need attention lest the functionality of the main grid/microgrid be impaired. Penetration of RES into electricity generation has introduced many technical and non-technical challenges such as power generation intermittence, power quality, reliability, safety, protection, load management, grid interconnection, controls, new regulations, integration of resources and operation economics which are now active areas of research around the globe [32], [33].

A new active power and voltage control scheme for single and parallel inverters that operate in the islanding mode is presented in [6]. The control scheme regulates both the active power and voltage magnitude of the inverter. The reactive power output from the voltage-regulated inverter was kept unregulated and left to change with the load because the inverter interfaced distributed energy sources have reactive power generation capabilities. The proposed control scheme can be applied in droop control method to handle the active power sharing among parallel inverter-interfaced distributed energy resources operated in the islanding mode. The disadvantage of this method is that the voltage changes with the reactive power as the load varies. This will bring instability in real implementation.

Operation modes of microgrids are described in [30] where as local-level distribution generation and system-level was described in [34]. Stability has been mention as a major control problem in [30] while PQ and voltage source inverter control schemes were mentioned as control strategies in grid connected and islanded operation of the microgrid [35], [36]. Each control scheme controls active and reactive power depending on the load demand. However limitation in applications for PQ and V-f control schemes and reasons for this limitation has been highlighted in [30].

Carrasco et al. [24] presented the integration of wind and photovoltaic (PV) to including appropriate storage-system technology as supplement and an alternative to large conventional central power stations specially in off grid areas.

In [14], Ou et al. presented multi-input power converters as controllers for grid connected and autonomous hybrid. Power electronics has been suggested as interface devices, and the new trend in the use of power electronics for the DG integration has been established. However, in all these cases the dynamic control of the power demand in the systems has been hardly mentioned.

The coordinated control of large number of distributed sources with probably conflicting requirements and limited communication is a very challenging problem imposing the adoption of distributed intelligence techniques. In order to achieve better control and accuracy, artificial intelligence and other optimization techniques have been used for tuning controller parameters [29].

For a complex structure microgrid, where reliability is priority, every microsource is connected to a point of common coupling (PCC) and incorporate communication infrastructure and control levels like microsource controller (MC), load controller (LC), microgrid control centre (MGCC) and distribution management system (DMS) [30], [37], [38]. However, schemes of this kind are complex and expensive to be implemented in rural areas of many developing countries.

IV. PROPOSED MICROGRID SYSTEM WITH MULTIPLE RENEWABLE ENERGY SOURCES

Fig. 1 shows the proposed system of an inverter interfaced microgrid supplying local load and a distant load S_1 . Multiple DG are concentrated to the common DC bus and used to supply some connected DC loads and storage. In interconnection mode of operation, decisions on local generation are based on the availability of the primary energy sources. Network restrictions, namely capacity of the MV/LV transformer or LV network congestions have to be strictly respected. When failures occur in the MV or HV system, the microgrid is automatically transferred to isolated islanding operation supply the local load connected to the microgrid. Seamless transition between the interconnected to the islanding mode is crucial to uninterrupted continuity of supply.

If a system disturbance provokes a general blackout at the upstream MV or HV networks, the microgrid can support during black-start, helping in this way the upstream. In the present networks, islanding operation is expensive since the costs of the generation plant and additional system automation and control must be borne.

In Fig. 1, the net dc bus power (P_{dc}) is determined by the sum of all connected microsourses to the respective bus. The accumulation involves power from all available sources and the storage system (P_s). The total power at the DC Busbar for n available energy sources and storage system is given as,

$$P_{dc} = \sum_{i=1}^n (P_{dc}(i)) \pm P_s \quad (1)$$

where, $P_{dc}(i)$ is the i^{th} DG connected to the regulated DC Busbar.

The DC bus power remains after consumption by some local DC loads, is converted to AC by the inverter to feed load \bar{S}_1 at a standard load voltage, \bar{V}_1 , as shown in Fig. 1. The complex power at inverter output is also shown in the figure. The active and reactive power at inverter output is given in exact mathematical formulation by (3) and (4);

$$\bar{S} = P + jQ \quad (2)$$

With load angle of ϕ , the active power and reactive power of the load are respectively given in (3) and (4).

$$P = S(\cos\phi) \quad (3)$$

$$Q = S(\sin\phi) \quad (4)$$

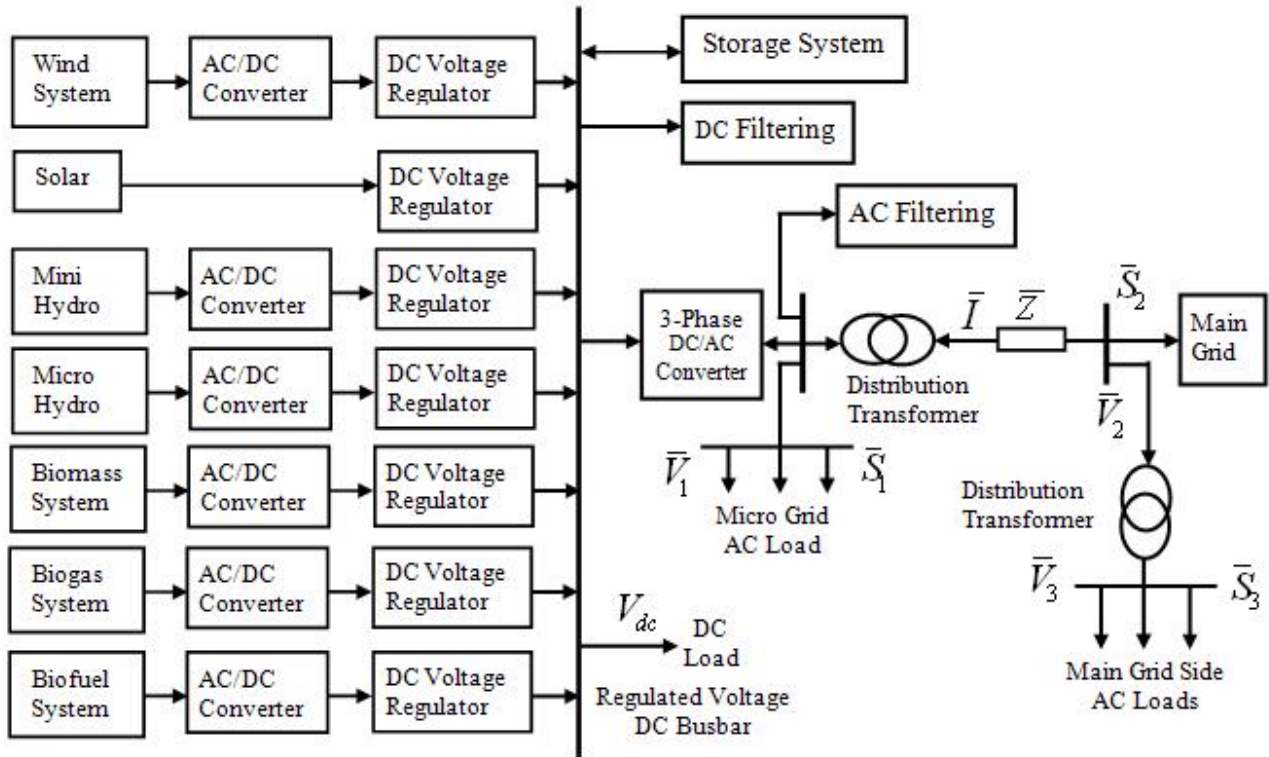

Fig. 1 Proposed configuration of the multisource microgrid

In (2) and (3) both resistance and reactance are taken into consideration during analysing and tuning controller parameters for the microgrid in contrast to previous designs where resistance is usually neglected. Maintaining stability and power quality in the islanding mode of operation requires the development of sophisticated control strategies and need to include both generation and demand sides. In a good quality power network there must be a match between supply and demand at any particular point of time, where power balance in (5) has to be applied.

$$\sum_{i=1}^n P_{S,i} + \sum_{i=1}^n Q_{S,i} = \sum_{j=1}^m P_{L,j} + P_R + \sum_{j=1}^m Q_{L,j} + Q_X \quad (5)$$

where n and m represents number of microsources and loads connected at the microgrid respectively, $P_{S,i}$, $P_{L,j}$ and P_R represents supplied and consumed active power, active power due to load and network resistive losses. On the other hand,

$Q_{S,i}$, $Q_{L,j}$ and Q_X represent supplied and consumed reactive power due to connected load and network reactance.

The proposed control strategy is anticipated to improve the stability and power quality of isolated microgrids and grid distribution based microgrid with greater penetration of DG at remote locations. A total voltage harmonic distortion (THD) of not greater than 5% as set by IEEE standard 519-1992 is also a target in this research.

V. PROPOSED RESEARCH METHODOLOGIES

A. Proposed Methodologies

- 1) Model of a single line diagram of a generalized power system incorporating microgrid as a single generator, load and grid, and derive mathematical representation of the generalized model.
- 2) Power electronics converters (AC-DC, DC-DC, DC-AC) are used as RES/DG interface to the power system depending on requirements. An inverter will be developed in this case and a passive filter utilized to minimize

harmonics for the current injected into electrical network. Energy storage will also be included as active power compensator during resource variability or change in load.

- 3) PQ control strategies in direct and quadrature axes (dq) reference frame will be developed and tested on the generalized model of grid connected microgrid. Load will be varied and study the dynamic behaviour and stability of the control and controlled system. Then the system will be allowed to operate as an island. Decoupled PQ will be developed and introduced into the system for further study. Short circuit and resource variability tests at fixed connected load will be performed in order to realize voltage status, frequency behavior and dynamic power flow. The outcome would tell the effectiveness of the proposed control technique and controller performance. Vector control technique will be developed and employed to control the inverter interface.
- 4) Study the effect of DG penetration in power systems by accessing the voltage profile along the distribution system. The system will be simulated without DG, with increased DG capacity, single load at the load bus, and with uniform load distribution along the distribution network. This study will enable to study the effects of increased DG capacity on network voltage profile and control aspects along the distribution network. A case study will also be made on real/potential grid connected Microgrid by applying real data to the model for further studies and verification.

B. Materials and Tools for Undertaking the Research Work

Matlab/Simulink Software will be used to undertake simulations and analytical studies of the proposed system. In addition RT-LAB Real-Time Digital Simulation and Controller facility has been acquired. The facility will be employed to undertake Real-Time Digital Simulation and possible prototype implementation of the proposed concept.

VI. CONCLUSIONS

Due to technological development, there is always increasing demand of energy requirement. Since electrical energy is the most convenient form of energy, there is continuous research work on the methods of conversion and integration of any available source of energy into electrical energy. This research direction is therefore prime as part of global research works on renewable energy sources, conversion and integration technologies. It is important to note that this research is very vital nationally and internationally. This is because the outcomes can enlighten on the possibilities of deploying several multiple sources of environmentally friendly renewable energy to supply Microgrids in rural areas.

ACKNOWLEDGMENT

Participants of this research are grateful for financial support provided by Sida from Sweden.

REFERENCES

- [1] J. J. Brey, A. Castro, E. Moreno and C. Garcia, "Integration of renewable energy sources as optimized solution for distributed generation" *IECON 02: 28th Annual conference of Industrial Electronics Society*, 2002, Nov. 2002, Vol. 4, pp. 3355-3359.
- [2] W. He "Grid Interaction of DG Units with Power Electronic Interfaces", *Master Thesis, Electrical Machines and Power Electronics*, Department of Electrical Engineering, Royal Institute of Technology, Stockholm Sweden.
- [3] I. Wasiak, R. Mienski, R. Pawelek, and P. Gburczyk, "Application of DST ATCOM Compensators for Mitigation of Power Quality Disturbances in Low Voltage Grid with Distributed Generation", in *Proceeding of 9th International Conference on Electrical Power Quality and Utilization 2007, EPQU 2007*, pp. 1-6, 2007.
- [4] O. Ippinnimo, S. Chowdhury, and S.P. Chowdhury, "Voltage Dip Mitigation with DG Integration: A Comprehensive Review", 2010 Joint International Conference on Power Electronics, Drives and Energy Systems (PEDES) and 2010 Power India, 2010, pp. 1 – 10.
- [5] A. Goikoetxea, M. Rodriguez, H. Binder and A. Milo, "Design of control strategies to improve grid integration in fixed speed wind energy with battery storage," 2010, on www.icrepq.com/icrepq/340-goikoetxea.pdf, accessed on March, 2013.
- [6] Z. Jiang and X. Yu, "Active Power-Voltage Control Scheme for Islanding Operation of Inverter-Interfaced Microgrids", *IEEE Power & Energy Society General Meeting 2009. PES '09*, 2009, pp. 1 – 7.
- [7] K. De Brabandere, B. Bolsens, J. Van den Keybus, A. Woyte, J. Driesen, R. Belmans, and K.U. Leuven, "A voltage and frequency droop control method for parallel inverters", *Proceedings of the 35th IEEE Power Electronics Specialists Conference*, Vol. 4, June 2004, pp. 2501-2507.
- [8] J. He and Yun Wei Li, "Analysis and Design of Interfacing Inverter Output Virtual Impedance in A Low Voltage Microgrid", *Energy Conversion Congress and Exposition (ECCE), 2010*, September 12-16, 2010, pp. 2857 – 2864.
- [9] E. Manla; A. Nasiri; and M. Hughes, "Modeling of Zinc Storage System for Integration with renewable Energy" *IEEE Industrial Electronics 35th Annual Conference 2009-IEEE IECON '09*, Nov3-5, 2009, pp. 3987-3992.
- [10] J. M. Rodriguez, Olovia Alonso, Miguel Duvison and Tomas Domingez, "The integration of renewable energy and the System Operation: The Special Regime Control Centre (CECRE) in Spain" *IEEE Power and Energy Society General Meeting –Conventional and Delivery of Electrical Energy in the 21st Century*, 2008, Pittsburgh, PA, USA, pp. 1-6.
- [11] M. Sakulin, K. Friedrich, U. Bachhiesl and R. Braunstein, "Policies for reasonable system integration of renewable energy sources in Austria", *International Conference on Clean Electrical Power*, 2009, 9-11 June 2009, Capri, Italy, pp. 540-544.
- [12] T. J. Hammons, "Integrating Renewable Energy Sources into European Grids" *Proceedings of the 41st International University Power Engineering Conference, 2006. UPEC'06*. Sept 2006, Newcastle upon Tyne, Vol.1, pp. 142-151.
- [13] B. M. Buchholz and Y. Sassnick, "The Germany Experience of the Grid Integration of Renewable Energy Sources" *Power Tech 2005*, IEEE Russia, St-Petersburg, June 2005, pp. 1-6.
- [14] T-C. Ou, Whei-Min Lin and Cong-Hui Huang, "A Multi-Input Power Converter for Hybrid Renewable Energy Generation System" *Sustainable Alternative Energy (SAE), 2009 IEEE PES/IAS Conference* Sept. 2009, Valencia, pp. 1-7.
- [15] A. Tisan, M. Cirstea, A. Buchman, A. Parera, S. Oniga and D. Ilea, "Holistic Modeling, Design and Optimal Digital Control of a Combined Renewable Power System" *Industrial Electronics (ISIE) International Symposium*, July 4-7, 2010 in Bari, Italy, pp. 2733 – 2738.
- [16] R. T. Jagaduri, G. Radman, "Modelling and control of distributed generation systems including PEM fuel cell and gas turbine", *Electric Power Systems Research*, Volume 77, Issue 1, January 2007, pp. 83-92
- [17] E. Santacana, G. Rackliffe, L Tang, and X. Feng, "Getting Smart" *IEEE Power and Energy magazine*, Vol. 8, No. 2, 2010, pp. 8-10.
- [18] S. B. Kjaer, J. K. Pedersen, and F. Blaabjerg, "A review of single-phase grid-connected inverters for photovoltaic modules", *IEEE Trans. Ind. Appl.*, vol. 41, no. 5, Sep./Oct. 2005, pp. 1292-1306.
- [19] R. Messenger, J. Ventre, "Photovoltaic Systems Engineering", *CRC Press LLC*, 2000.

- [20] M. Yamaguchi and A Luque, "High efficiency and high concentration in photovoltaics", *IEEE Trans. Electron Devices*, vol. 46, no. 10, Oct. 1999, pp. 2139-2144.
- [21] L. Gao, R.A. Dougal, and S. Liu, "Power enhancement of an actively controlled battery/ultra-capacitor hybrid," *IEEE Trans. Power Electronics*, vol. 20, No. 1, Jan. 2005, pp. 236-243.
- [22] B. Lasseter, "Microgrids, in *IEEE Proc. Power Engineering Society Winter Meeting*, 2001, Vol. 1, 28, pp. 146-149.
- [23] I. Serban, R. Teodorescu, J. M. Guerrero, C. Marinescu, "Modeling of Autonomous Micro grid for renewable Energy Sources Integration" *Industrial Electronics, 2009, IECON '09 35th Annual Conference*, Nov 2009, pp. 4311-4316.
- [24] J. M. Carrasco, L. G. Franquelo, J. T. Bialasiewicz, E. Galvan, R. C. P. Guisado, Ma. A. M. Prats, J. I. Leon, and N. Moreno-Alfonso, "Power Electronic Systems for Grid Integration of Renewable Energy Sources: A survey", *IEEE Transactions on Industrial Electronics*, vol. 53, No.4, June 2006, pp. 1002-1016.
- [25] D. G. Holmes, Thomas A. Lipo, (2003) "Pulse Width Modulation for Power Converters: Principle and Practices", *IEEE Press series on Power Engineering, John Wiley & Sons, Inc.*
- [26] B. M. M., Mwinyiwiwa, "An Approach for the development of a multipurpose Power Electronics Research Facility" *ICEET 99 Conference*, University of Dar es Salaam, Tanzania, 1999, pp. 72-77.
- [27] B. Masamila, A. H. Nzali, B. M. M., "Design and construction of a multipurpose Voltage Source Converter", ICEET 01, University of Dar es Salaam, Tanzania, 2001, pp. EM25-EM28, 2001.
- [28] N. Gregory, "Multipurpose Digital Controller (MDC) for Motor Drives" *Masters Thesis, University of Dar es Salaam, 2009.*
- [29] R. C. Bansal, "Modelling and automatic reactive power control of isolated wind-diesel hybrid power systems using ANN" *Energy Conversion and Management*, Volume 49, Issue 2, February 2008, pp. 357-364.
- [30] J. Li, J. Su, X. Yang and T. Zhao, "Study on Microgrid Operation Control and Black Start" *4th International Conference on Electric Utility Deregulation and Restructuring and Power Technologies (DRPT)*, 6-9 July 2011, Weihai, Shandong, China, pp. 1652 – 1655.
- [31] A. Ghafouri, M.R. Zolghadri and M. Ehsan, "Power System Stability Improvement Using Self-Tuning Fuzzy Logic Controlled STATCOM" *EUROCON 2007 The International Conference on "Computer as a Tool"* Warsaw, September 9-12, pp. 1444 – 1449.
- [32] J. T. Bialasiewicz, "Renewable Energy Systems with Photovoltaic Power Generators: Operation and Modelling" *IEEE Transactions on Industrial Electronics*, Vol. 55, No. 7, July, 2008, pp. 2752-2758.
- [33] F. Blaabjerg, R. Teodorescu, M. Lissere, and A. V. Timbus, "Overview of Control and Grid Synchronization for Distributed Power Generation Systems," *IEEE Transactions on Industrial Electronics*, Vol. 53, No. 5, Oct. 2006, pp. 1398-1409.
- [34] C.L Moreira, Resende F.O and Lopes J.A. Pecas, "Using low voltage Microgrids for service restoration," *IEEE Transactions on Power Systems*, Vol-22, No-1, February 2007, pp. 395-403.
- [35] T. L. Vandoorn, B. Meersman, L. Degroote, B. Renders and L. Vandeveldde, "A Control Strategy for Islanded Microgrids With DC-Link Voltage Control", *IEEE Transactions on Power Delivery*, Vol. 26, No. 2, 2011, pp.703 – 713.
- [36] A. S. Dobakhshari and S. Azizi, and A. M. Ranjbar, "Control of Microgrids: Aspects and Prospects" *2011 International Conference on Networking, Sensing and Control*, Delft, the Netherlands, April 11-13, 2011, pp. 38 - 43
- [37] P. Basak, A.K. Saha, S. Chowdhury and S.P. Chowdhury, "Microgrid: Control Techniques and Modelling" *2009 Universities Power Engineering Conference (UPEC), 2009 Proceedings of the 44th International Publication*, 2009, pp. 1 – 5.
- [38] P. Maffezzoni, L. Codecasa, and D. D'Amore, "Modeling and Simulation of a Hybrid Photovoltaic Module Equipped With a Heat-Recovery System" *IEEE Transactions on Industrial Electronics*, Vol. 56, No. 11, November 2009, pp. 4311-4318.