

# Investigation on the Behavior of Conventional Reinforced Coupling Beams

Akash K. Walunj, Dipendu Bhunia, Samarth Gupta, Prabhat Gupta

**Abstract**—Coupled shear walls consist of two shear walls connected intermittently by beams along the height. The behavior of coupled shear walls is mainly governed by the coupling beams. The coupling beams are designed for ductile inelastic behavior in order to dissipate energy. The base of the shear walls may be designed for elastic or ductile inelastic behavior. The amount of energy dissipation depends on the yield moment capacity and plastic rotation capacity of the coupling beams. In this paper, an analytical model of coupling beam was developed to calculate the rotations and moment capacities of coupling beam with conventional reinforcement.

**Keywords**—Design studies, computational model(s), case study/studies, modeling, coupling beam.

## I. INTRODUCTION

WHEN two shear walls are joined by beams at fixed intervals along its height, it is called a coupled shear wall; these beams are the primary factors which control the behavior of coupled shear walls. The coupling beams are designed for ductile inelastic behavior for the purpose of energy dissipation while the base of the shear walls can be designed for either elastic behavior or ductile inelastic behavior.

Coupling beams are quite short and deep and generally have span/depth ratios of two or even lower, since the widths of door and window openings usually range from 1.0 to 1.5 m. Being similar to deep beams, coupling beams with span/depth ratios lower than 2.0 have a predisposition to fail in shear rather than in flexure. During a major earthquake, if the coupling beams were very strong, the wall units might fail due to the large axial forces and bending moments induced in them without prior yielding of the coupling beams.

As the walls are taking vertical loads and are the major lateral loads resisting elements, any damage to the walls could endanger the safety of the building and render the repair after earthquake very difficult. On the other hand, if the coupling beams were not too strong, they would yield and dissipate the excessive vibration energy before the wall units yield thereby reducing the axial forces induced in the walls and protecting the walls from being damaged. Hence, the coupling beams should be designed to yield before the walls yield, but then the coupling beams would be subjected to a certain ductility demand. In any case, the earthquake resistance of a coupled shear wall structure is highly dependent on the nonlinear behavior, especially the strength and ductility of the coupling beams. The amount of earthquake energy dissipation is

governed by the yield moment capacity and plastic rotation capacity of the coupling beams [9]-[23].

However [1], [6]-[9] show the inconsistent modeling parameters and inconsistent evaluative parameters of coupling beams described as follow:

1. As per [7], [8], the rotational capacities of beam depends on size of wall ( $t_w, L_w$ ) which is illogical.

2. When shear span to depth ratio  $\phi \leq 2$  or aspect ratio  $L_b/d_b \leq 4$ , the behavior of all types of RCC coupling beams is controlled by shear [21]. For this reason, as aspect ratio  $\left(\frac{L_b}{d_b}\right)$  of diagonally reinforced beam is less

than 1.5, it means that the behavior of diagonally reinforced beam is controlled by shear. Whereas, [1] and [7] show that diagonally reinforced coupling beam behavior is controlled by flexure which is not acceptable.

3. Conventional longitudinal reinforcement with non-conforming transverse reinforcement as per [1], [7], [8] is not accepted for new construction.

4. If the behavior of coupling beam is controlled by flexure [aspect ratio  $\left(\frac{L_b}{d_b}\right)$  is greater than 4], the length of the

coupling beam is quite larger. It has been observed [18] that weakly coupled shear walls can be obtained for larger span of the coupling beam and the design results of this type of coupled shear walls were inconsistent with regard to the ductility and energy dissipation during earthquake motion. Hence, it can be said that rotational capacity of coupling beams controlled by flexure as per [1], [7], [8] cannot be accepted.

5. As per [1], [7], [8], regarding the conditions of  $\frac{Shear}{t_w L_w \sqrt{f_c}}$  or  $\frac{Shear}{b_w d \sqrt{f_c}} \leq 3$  or  $\geq 6$  are confusing.

6. Similarly, for aspect ratio of  $\frac{L_b}{d_b} = 1.5$  Galano and Vignoli

[9] shows different results regarding the ultimate rotation of various RCC coupling beams in comparison with the results made by Englekirk [6].

Hence, in this paper an analytical model of coupling beam was developed to calculate the rotations and moment capacities of coupling beam with conventional reinforcement.

Dr. Dipendu Bhunia is with the BITS Pilani, Rajasthan, India (e-mail: dbhunia@pilani.bits-pilani.ac.in).

TABLE I  
INVESTIGATIVE MODEL OF COUPLING BEAM IN ATENA2D (2006) AS PER [3]-[6], [9]

Type	$L_b$ (m)	Reinforced Steel	
		Longitudinal	Transverse
Conventional reinforced coupling beam with longitudinal and transverse conforming reinforcement	0.6	8-10 $\phi$	2-legged 16 $\phi$ @200 c/c
		8-20 $\phi$	2-legged 25 $\phi$ @200 c/c
	0.9	8-10 $\phi$	2-legged 16 $\phi$ @200 c/c
		8-20 $\phi$	2-legged 25 $\phi$ @200 c/c
	1.2	8-10 $\phi$	2-legged 16 $\phi$ @200 c/c
		8-20 $\phi$	2-legged 25 $\phi$ @200 c/c

## II. ANALYTICAL MODELING IN ATENA2D

Since the above discussions show the contradictory behavior of coupling beam, more study is required to investigate into the limitations on behavior of coupling beams. ATENA2D (2006) [2] was considered to carry out this study.

Four parts are created in the PART module

- i) Shear wall 1
- ii) Shear wall 2
- iii) Reinforcement
- iv) Coupling beam

### A. Shear Wall

Dimensions of the shear wall were 300mm thick with 4m length and 3m height. Minimum reinforcement in the shear wall was taken as 0.25% of its gross area @ 450 c/c.

### B. Reinforcement Layouts

There were six RCC coupling beams with conventional reinforcement layout considered in the analytical program using ATENA2D [2]. For the layout, the cross section of the coupling beam was considered as 600mm (depth,  $d_b$ )  $\times$  300mm (width,  $b_b$ ) and the beam span-depth ratio ( $\frac{L_b}{d_b}$ ) was

considered as 1, 1.5 and 2. The chosen length and depth of coupling beam are 0.6 x 0.6, 0.9 x 0.6, and 1.2 x 0.6.

### C. Material Properties in ATENA 2D

**Material no. 1** [Concrete (M20 grade)]: shear wall 1 and shear wall 2

Name: concrete\_Plane Stress Elastic Isotropic  
Type: CCPlaneStressElastIsotropic  
Elastic modulus  $E = 2.240E+04$  [MPa]  
Poisson's ratio  $\nu = 0.200$  [-]  
Specific material weight  $Rho = 2.300E-02$  [MN/m<sup>3</sup>]  
Coefficient of thermal expansion  $Alpha = 1.200E-05$  [1/K]

### Material no. 2

Name: SBeta Material: coupling beam  
Type: CCSBETAMaterial  
Elastic modulus  $E = 2.240E+04$  [MPa]  
Poisson's ratio  $\nu = 0.200$  [-]  
Tensile strength  $F_t = 3.130E+00$  [MPa]  
Compressive strength  $F_c = -2.000E+01$  [MPa]  
Type of tension softening: Exponential  
Specific fracture energy  $G_f = 4.421E-05$  [MN/m]

Crack model: Fixed

Compressive strain at compressive strength in the uniaxial compressive test  $Eps_C = -2.000E-03$  [-]

Reduction of compressive strength due to cracks  $CompRed = 0.800$  [-]

Type of compression softening: Crush Band

Critical compressive displacement  $Wd = -5.0000E-04$  [m]

Shear Retention Factor Variable

Tension-compression interaction: Linear

Specific material weight  $Rho = 2.300E-02$  [MN/m<sup>3</sup>]

Coefficient of thermal expansion  $Alpha = 1.200E-05$  [1/K]

**Material no. 3** [Steel (Fe 415 grade)]

Name: Reinforcement

Type: CCREinforcement

Type: BiLinear

Elastic modulus  $E = 2.100E+05$  [MPa]

Sigma Y = 415.000 [MPa]

Specific material weight  $RHO = 7.850E-02$  [MN/m<sup>3</sup>]

Coefficient of thermal expansion  $ALPHA = 1.200E-05$  [1/K]

$$V = \frac{F \times L_w}{L_w + L_b} \quad (1)$$

where, V is shear force in the beam

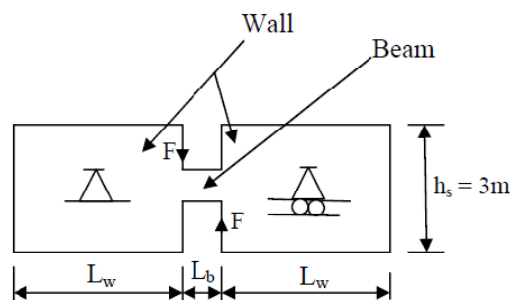

Fig. 1 Sketch of the investigative model

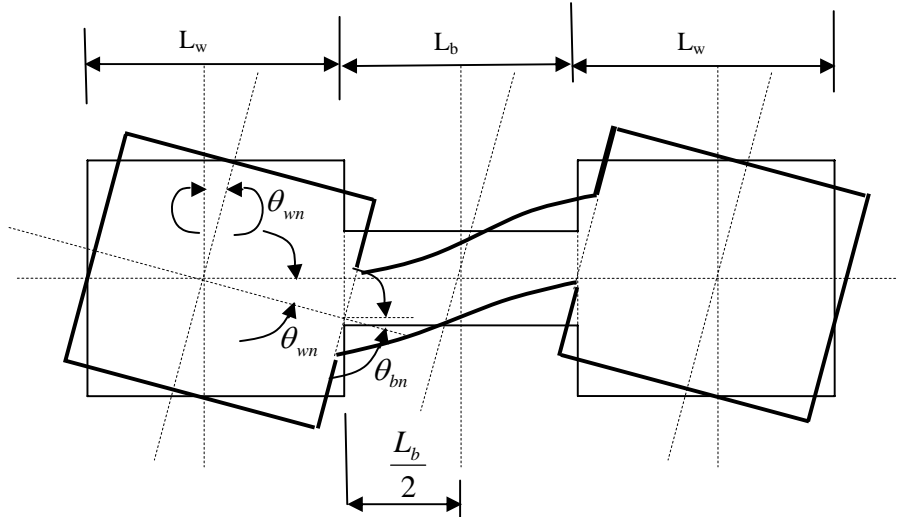

Fig. 2 Deformed shape of a *i*th storey symmetrical coupled shear walls

The rotation of coupling beam in each storey is determined as follows:

Rotation of coupling beam at *i*th storey for symmetrical walls [6] as per Fig. 2 is given by

$$\theta_{bi} = \theta_{wi} \left( 1 + \frac{L_w}{L_b} \right) \quad (2)$$

where,  $\theta_{wi}$  is rotation of wall at *i*th storey and  $L_w$  = depth of wall,  $L_b$  = length of coupling beam.

**D. Reinforcements**

Reinforcement property was modeled according to Table I for each type of beam and results were analyzed by using Solution parameters with Newton-Raphson Method.

**III. RESULTS AND DISCUSSIONS**

Following tables show the results including discussions for the conventional reinforced coupling beams with conforming transverse reinforcement which were modeled in ATENA-2D [2] as per Fig. 1.

TABLE II  
 COMPARING THE MODELING PARAMETERS AND NUMERICAL ACCEPTANCE CRITERIA WITH FEMA 273 (1997) AND FEMA 356 (2000) [7]-[8]

Longitudinal reinforcement and transverse reinforcement	Shear $t_w L_w \sqrt{f'_c}$	Rotational limit at collapse prevention level (CP) in radians				Reinforcement	ATENA2D			Crack width in coupling beam at CP level in meters by ATENA2D		
		Member controlled by flexure		Member controlled by shear			$L_b = 0.6m$	$L_b = 0.9m$	$L_b = 1.2m$	$L_b = 0.6m$	$L_b = 0.9m$	$L_b = 1.2m$
		FEMA2	FEMA3	FEMA2	FEMA3							
Conventional longitudinal reinforcement with conforming transverse reinforcement	$\leq 3$	73	56	73	56	8-10 $\phi$ and 2-legged	0.023	0.028	0.032	0.005	0.015	0.019
	$\geq 6$	0.015	0.02	0.010	0.016	16 $\phi$ @200 c/c 8-20 $\phi$ and 2-legged 25 $\phi$ @200 c/c	0.019	0.020	0.022	0.017	0.018	0.021

TABLE III  
COMPARING THE MODELING PARAMETERS AND NUMERICAL ACCEPTANCE CRITERIA WITH ATC 40 (1996) [1]

Longitudinal reinforcement and transverse reinforcement	$\frac{Shear}{b_w d \sqrt{f'_c}}$	Rotational limit at collapse prevention level (CP) in radians						Crack width in coupling beam at CP level in meters by ATENA2D		
		Member controlled by flexure ATC 40	Member controlled by shear ATC 40	Reinforcement	ATENA2D $L_b = 0.6m$ $L_b = 0.9m$ $L_b = 1.2m$			$L_b = 0.6m$	$L_b = 0.9m$	$L_b = 1.2m$
Conventional longitudinal reinforcement with conforming transverse reinforcement	$\leq 3$	0.025	0.018	8-10 $\phi$ and 2-legged 16 $\phi$ @200 c/c	0.023	0.028	0.032	0.005	0.015	0.019
	$\geq 6$	0.015	0.012	8-20 $\phi$ and 2-legged 25 $\phi$ @200 c/c	0.019	0.020	0.022	0.017	0.018	0.021

TABLE IV  
COMPARING THE VALUES OF SHEAR PARAMETERS OF FEMA 273 (1997), FEMA 356 (2000), ATC 40 AND ATENA 2D [1], [2], [7], [8]

$L_b/d_b$	FEMA 273, FEMA 356	ATENA 2D	ATC 40	ATENA 2D	ATENA 2D
	$\frac{Shear}{t_w L_w \sqrt{f'_c}}$			$\frac{Shear}{b_w d \sqrt{f'_c}}$	$\frac{Shear}{t_b L_b \sqrt{f'_c}}$
1	$\leq 3$	0.08	$\leq 3$	0.56	0.56
	$\geq 6$	0.18	$\geq 6$	1.19	1.19
1.5	$\leq 3$	0.05	$\leq 3$	0.32	0.22
	$\geq 6$	0.12	$\geq 6$	0.70	0.47
2	$\leq 3$	0.04	$\leq 3$	0.28	0.14
	$\geq 6$	0.10	$\geq 6$	0.58	0.29

It was observed from the Tables II and III that the rotational limit at collapse prevention level (CP) were in the similar trends in FEMA 273, FEMA 356, ATC 40 and the results of ATENA 2D. It was also seen that the crack widths were more but rotations were less for the conditions of more shear, which is quite well understood. In addition, Tables II-IV were showing incremental rotational capacities with lesser shear and moment capacities with increases of  $L_b$  or  $L_b/d_b$  ratio. As per the literatures [18], greater  $L_b/d_b$  ratio gives weakly coupled shear walls which are not accepted. Table IV was also

showing that there was no case where  $\frac{Shear}{t_w L_w \sqrt{f'_c}}$  or  $\frac{Shear}{b_w d \sqrt{f'_c}}$

achieves  $\leq 3$  or  $\geq 6$ . However, based on the conditions of

$\frac{Shear}{b_w d \sqrt{f'_c}}$  or  $\frac{Shear}{t_b L_b \sqrt{f'_c}}$  greater ratios were obtained specially

in the case of  $\frac{Shear}{b_w d \sqrt{f'_c}}$ .

#### IV. CONCLUSIONS

- Rotational capacities of beam depend on size of the beam, i.e.  $L_b$ ,  $b_w$  and  $d$ .
- The behavior of the coupling beam should be governed by shear.
- The aspect ratio ( $L_b/d_b$ ) of the coupling beam should be less than 1.5.
- The condition in the table given in FEMA 273, FEMA 356 and ATC 40 should not never be either  $\leq 3$  or  $\geq 6$ .
- Finally, rotational limit at collapse prevention level (CP) for conventional reinforced coupling beam should be in the range of 0.01-0.02 radian.

#### ACKNOWLEDGMENTS

The research presented in this paper is primarily supported by BITS Pilani (Research Initiation Grant). Any opinions, findings, and conclusions or recommendations expressed in this paper are those of the authors and do not necessarily reflect the views of the sponsors.

REFERENCES

- [1] Applied Technology Council: ATC-40 Report (1996): “*Seismic Evaluation and Retrofit of Concrete Buildings*”, Volume I, Redwood City, California.
- [2] ATENA2D: Version 3.3.0.3 (2006), *Nonlinear Finite Element Integrated Analysis*, Cervenka Consulting, Praha, Czech Republic.
- [3] Bureau of Indian Standards: IS-456 (1978) (SP-16), *Design Aids for Reinforced Concrete*, New Delhi, India.
- [4] Bureau of Indian Standards: IS-13920 (1993), “*Ductile Detailing of Reinforced Concrete Structures Subjected to Seismic Forces – Code of Practice*”, New Delhi, India.
- [5] Bureau of Indian Standards: IS-456 (2000), *Plain and Reinforced Concrete – Code of Practice*, New Delhi, India.
- [6] Englekirk, R.E. (2003), “*Seismic Design of Reinforced and Precast Concrete Buildings*”, John Wiley, NY, ISBN.
- [7] Federal Emergency Management Agency: FEMA-273 (1997), “*NEHRP Guidelines for the Seismic Rehabilitation of Buildings*, Washington”, DC, U.S.A.
- [8] Federal Emergency Management Agency: FEMA-356 (2000), “*Prestandard and Commentary for the Seismic Rehabilitation of Buildings*”, Washington, DC, U.S.A.
- [9] Galano, L., and Vignoli, A. (2000), “Seismic Behavior of Short Coupling Beams with Different Reinforcement Layouts”, *ACI Structural Journal*, 97(6), 876-885.
- [10] Harries, K.A. (2001), “Ductility and Deformability of Coupling Beams in Reinforced Concrete Coupled Walls”, *Earthquake Spectra*, 17(3), 457-478.
- [11] Harries, K.A., Moulton, J. D., and Clemson, R.L. (2004), “Parametric Study of Coupled Wall Behavior-Implications for the Design of Coupling Beams”, *Journal of Structural Engineering*, ASCE, 130(3), 480-488.
- [12] Hindi, R.A., and Hassan, M. A. (2004), “Shear Capacity of Diagonally Reinforced Coupling Beams”, *Engineering Structures*, 26, 1437-1446.
- [13] J. Awrejcewicz, I. Andrianov, L. I. Manevitch, *Asymptotical Mechanics of Thin-Walled Structures*, Springer, Berlin, 2004.
- [14] J. Awrejcewicz, D. Sendkowski, 'How to predict stick-slip chaos in R4', *Physics Letters A*, 330, 2004, 371-376.
- [15] J. Awrejcewicz, A.V. Krysko, M.V. Zhigalov, O.A. Saltykova, V.A. Krysko, 'Chaotic vibrations in flexible multi-layered Bernoulli-Euler and Timoshenko type beams', *Latin American Journal of Solids and Structures*, 5 (4), 2008, 319-363.
- [16] J. Awrejcewicz, V.A. Krysko, O.A. Saltykova, Yu. B. Chebotyrevskiy, 'Nonlinear vibrations of the Euler-Bernoulli beam subject to transversal load and impact actions', *Nonlinear Studies*, 18(3), 2011, 329-364.
- [17] Mohr, D. S., Lehman, D. and Laura, L. (2007), “Performance Based Design and Nonlinear Modeling of Coupled Shear Walls”, *Proceedings of the Structural Engineering Congress*, ASCE, LA, California.
- [18] Munshi, J.A., and Ghosh, S.K. (2000), “Displacement-Based Seismic Design for Coupled Wall Systems”, *Earthquake Spectra*, 16(3), 621-642.
- [19] Paulay, T. (1971a), “Coupling Beams of Reinforced Concrete Shear Walls”, *Journal of Structural Engineering*, ASCE, 97(ST3), 843-862.
- [20] Paulay, T. and Binney, J.R. (1974), “Diagonally Reinforced Coupling beams of Shear Walls”, *ACI Special Publication 42*, Detroit, 2, 579-598.
- [21] Penelis, G.G., and Kappos, A.J. (1997), “*Earthquake-resistant concrete structures*”, E&FN SPON, NY, ISBN.
- [22] Xuan, G., Shahrooz, B. M., Harries, K. A. and Rassati, G. A. (2008), “A Performance-Based Design Approach for Coupled Core Wall Systems with Diagonally Reinforced Concrete Coupling Beams”, *Advances in Structural Engineering*, 11 (3), 265-280.
- [23] Zhao, Z.Z., Kwan, A. K. H. and He, X. G. (2004), “Nonlinear Finite Element Analysis of Deep Reinforced Concrete Coupling Beams”, *Engineering Structures*, 13-25.