

Influence of Tether Length in the Response Behavior of Square Tension Leg Platform in Regular Waves

Amr R. El-Gamal, Ashraf Essa, Ayman Ismail

Abstract—The tension leg platform (TLP) is a vertically moored structure with excess buoyancy. The TLP is regarded as moored structure in horizontal plan, while inherit stiffness of fixed platform in vertical plane. In this paper, a numerical study using modified Morison equation was carried out in the time domain to investigate the influence of nonlinearities due to hydrodynamic forces and the coupling effect between surge, sway, heave, roll, pitch and yaw degrees of freedom on the dynamic behavior of TLP's. The stiffness of the TLP was derived from a combination of hydrostatic restoring forces and restoring forces due to cables and the nonlinear equations of motion were solved utilizing Newmark's beta integration scheme. The effect of tethers length and wave characteristics such as wave period and wave height on the response of TLP's was evaluated.

Only uni-directional waves in the surge direction was considered in the analysis. It was found that for short wave periods (i.e. 10 sec.), the surge response consisted of small amplitude oscillations about a displaced position that is significantly dependent on tether length, wave height; whereas for longer wave periods, the surge response showed high amplitude oscillations about that is significantly dependent on tether length.

Keywords—Hydrodynamic wave forces, tension leg platforms, tethers length, wave characteristic.

I. INTRODUCTION

A Tension Leg Platform (TLP) is one of the compliant structures which are well established in offshore industry to minimize the structure resistance to environmental loads by making the structure flexible. The TLP is basically a floating structure moored by vertical cables or "tethers". Tethers are pre-tensioned to the sea floor due to the excess buoyancy of the platform. This tension fluctuates due to variable submergence, wind gustiness, wave loading and resulting coupled response. The instantaneous tension in tethers acts as a restoring force.

The TLP can be modeled as a rigid body with six degrees of freedom (refer to Fig. 1), which can be conveniently divided into two categories, those controlled by the stiffness of tethers, and those controlled by the buoyancy. The former category includes motion in the vertical plane and consists of heave, roll and pitch; whereas the latter comprises the horizontal motions of surge, sway and yaw.

A. R. is with the Civil Engineering Department, Faculty of Engineering at Benha, Benha University, Egypt (phone: 002- 01000941720; fax: 13512; e-mail: engamr Ramadan@yahoo.com).

A. E. is with the Civil Engineering Department, National Building Research Center, Egypt (phone: 00201143043638; fax: 1770; e-mail: ashraf_20022003@yahoo.com).

A. I. is with the Steel and Structure Engineering Department, National Building Research Center, Egypt (phone: 00201143043638; fax: 1770; e-mail: ayman.m.ismail@gmail.com).

A number of studies have been conducted on the dynamic behavior of TLP's under both regular and random waves, Chandrasekaran and Roy [3]. They presented phase space studies of offshore structures subjected to nonlinear dynamic loading through Poincare maps for certain hydrodynamic parameters. Bhattacharya et al. [2] investigated coupled dynamic behavior of a mini TLP giving special attention to hull-tether coupling. Ketabdari and Ardakani [6] developed a computer program to evaluate the dynamic response of sea-star TLP to regular wave forces considering coupling between different degrees of freedom. Wave forces were computed numerically using linear wave theory and Morison equation, neglecting diffraction effects due to small ratio of diameter to wave length. Low [9] presented a formulation for the linearization of the tendon restoring forces of a TLP. Chandrasekaran et al. [4] conducted dynamic analysis of triangular TLP models at different water depths under the combined action of regular waves and an impulse load affecting the TLP column. Chandrasekaran et al. [5] focused on the response analysis of triangular tension leg platform (TLP) for different wave approach angles and studied its influence on the coupled dynamic response of triangular TLPs. Kurian et al. [7] developed a numerical study on the dynamic response of square TLPs subjected to regular and random waves. They also conducted parametric studies with varying parameters such as water depth, pretension, wave angle and position of center of gravity. Kurian et al. [8] developed a numerical study on determining the dynamic responses of square and triangular TLPs subjected to random waves. They found that the responses of triangular TLPs are much higher than those of square TLP. A. M. Abou-Rayan, Ayman A. Seleemah, and Amr R. El-gamal [1] developed a numerical study on determining the dynamic responses of TLPs subjected to regular wave. They found that coupling between various degrees of freedom has insignificantly dependent on the wave height; whereas for longer wave periods of 15 sec.

In this paper, a numerical study was conducted to investigate the dynamic response of a square TLP (shown in Fig. 2) under hydrodynamic forces considering all degrees of freedom of the system. The analysis was carried out using modified Morison equation in the time domain with water particle kinematics using Airy's linear wave theory. The influence of nonlinearities due to hydrodynamic forces and the coupling effect between surge, sway, heave, roll, pitch and yaw degrees of freedom on the dynamic behavior of TLP's was investigated. The stiffness of the TLP was derived from a combination of hydrostatic restoring forces and restoring forces due to cables. The nonlinear equations of motion were

solved utilizing Newmark's beta integration scheme. The effect of tethers length and wave characteristics such as wave period and wave height on the response of TLP's was evaluated. Only uni-directional waves in the surge direction was considered in the analysis

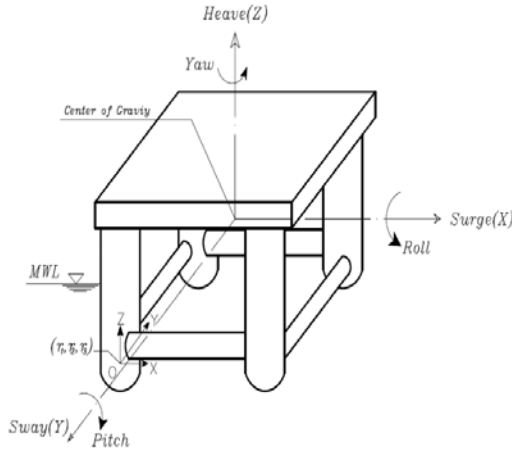

Fig. 1 The global and local coordinate system of TLP

II. STRUCTURAL IDEALIZATION AND ASSUMPTIONS

The general equation of motion of the square configuration TLP model under a regular wave is given as

$$[M]\{\ddot{x}\} + [C]\{\dot{x}\} + [K]\{x\} = \{F(t)\} \quad (1)$$

where, $\{x\}$ is the structural displacement vector, $\{\dot{x}\}$ is the structural velocity vector, $\{\ddot{x}\}$ is the structural acceleration vector; $[M]$ is the structure mass matrix; $[C]$ is the structure damping matrix; $[K]$ is the structure stiffness matrix; and $\{F(t)\}$ is the hydrodynamic force vector.

The mathematical model derived in this study assumes that the platform and the tethers are treated as a single system and the analysis is carried out for the six degrees of freedom under different environmental loads where wave forces are estimated at the instantaneous equilibrium position of the platform utilizing Morison's equation and using Airy's linear wave theory. Wave force coefficients, C_d and C_m , are the same for the pontoons and the columns and are independent of frequencies as well as constant over the water depth. The following assumptions were made in the analysis.

- 1) Change in pre-tension is calculated at each time step, so the equation of equilibrium at each time step modifies the elements of the stiffness matrix.
- 2) The platform has been considered symmetrical along the surge axis. Directionality of wave approach to the structure has been ignored in the analysis and only a uni-directional wave train has been considered.
- 3) The damping matrix has been assumed to be mass and stiffness proportional.
- 4) The force on tethers (gravity, inertia, and drag, hydrostatic and hydrodynamic forces) has been neglected because of its small area and also the tether curvature is not

significant in motion; only the axial forces acting on tethers have been considered.

- 5) Hydrodynamic forces on connecting members and mooring legs have been neglected.
- 6) The wave, current and structure motions are taken to occur in the same plane and in the same direction, the interaction of wave and current has been ignored.
- 7) Integration of hydrodynamic inertia and drag forces are carried out up to the actual level of submergence, when variable submergence is considered.

III. DEVELOPMENT OF A RECTANGLE TLP MODEL

A. Draft Evaluation

At the original equilibrium position, Fig. 2, summation of forces in the vertical direction gives:

$$W + T = F_B \quad (2)$$

We find that

$$D_r = \frac{[(W + T) / (0.25 \rho \pi g)] - (2D_p^2 s_a) - (2D_p^2 s_b)}{4D_c^2} \quad (3)$$

where, F_B is the total buoyancy force; W is the total weight of the platform in air; T is the total instantaneous tension in the tethers; T_0 is the initial pre-tension in the tether; ρ is the mass density of sea water; D_c is the diameter of TLP columns; D_p is the diameter of pontoon; S_a and S_b are the length of the pontoon between the inner edges of the columns in the x and y directions, respectively; and D_r is the draft.

B. Stiffness Matrix of Rectangle TLP Configuration

The stiffness of the platform is derived from a combination of hydrostatic restoring forces and restoring forces due to the cables. Restoring force for motions in the horizontal plane (surge, sway, and yaw) are the horizontal component of the pretension in the cables, while restoring forces for motions in the vertical plane arise primarily from the elastic properties of the cables, with a relatively small contribution due to hydrostatic forces.

The coefficients, K_{ij} , of the stiffness matrix of square TLP are derived from the first principles as the reaction in the degree of freedom i , due to unit displacement in the degree of freedom j , keeping all other degrees of freedom restrained. The coefficients of the stiffness matrix have nonlinear terms. Moreover, the tether tension changes due to the motion of the TLP in different degrees of freedom leads to a response-dependent stiffness matrix. The coefficients of the stiffness matrix $[K]$ of a rectangle TLP are

$$[K] = \begin{pmatrix} K_{11} & 0 & 0 & 0 & K_{15} & 0 \\ 0 & K_{22} & 0 & K_{24} & 0 & 0 \\ K_{31} & K_{32} & K_{33} & K_{34} & K_{35} & K_{36} \\ 0 & K_{42} & 0 & K_{44} & 0 & 0 \\ K_{51} & 0 & 0 & 0 & K_{55} & 0 \\ 0 & 0 & 0 & 0 & 0 & K_{66} \end{pmatrix} \quad (4)$$

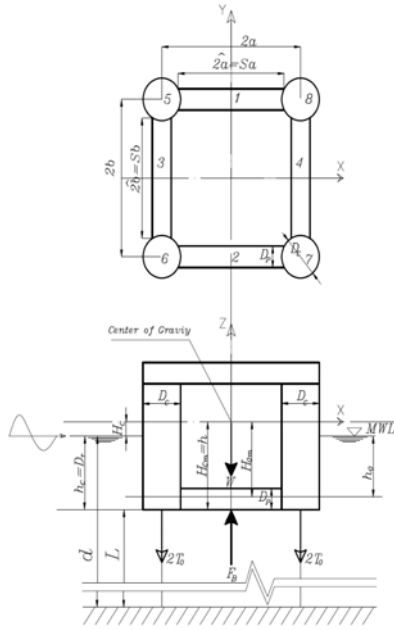

Fig. 2 The Square TLP (plan and elevation)

For more detailed about the derivation of the stiffness matrix, the reader is referred to [1]

The overall stiffness matrix given by (4) shows:

- 1) The presence of off-diagonal terms, which reflects the coupling effect between the various degrees of freedom.
- 2) The coefficients depend on the change in the tension of the tethers, which is affecting the buoyancy of the system. Hence, the matrix is response dependent.
- 3) Hence, during the dynamic analysis, the [K] matrix is not constant for all time instants, but its components are continuously changing at each time step depending upon the response values at the previous time step.

C. Mass Matrix, [M]

The mass matrix is assumed to be lumped at each degree of freedom. Hence, it is diagonal in nature and is constant. However, the added mass, M_a , due to the water surrounding the structural members has been considered up to the mean sea level (MSL) and arising from the modified Morison equation. The presence of off diagonal terms in the mass matrix indicates a contribution of the added mass due to the hydrodynamic loading. The fluctuating components of added mass due to the variable submergence of the structure in water is considered in the force vector depending upon whether the sea surface elevation is above or below the MSL. The loading will be attracted only in the surge, heave and pitch degrees of freedom due to the unidirectional wave acting in the surge direction on a symmetric configuration of the platform about the x and z axes.

Therefore, the mass matrix can be written as

$$[M] = \begin{pmatrix} M + M_{a11} & 0 & M_{a13} & 0 & M_{a15} & 0 \\ 0 & M & 0 & 0 & 0 & 0 \\ M_{a31} & M_{a32} & M + M_{a33} & 0 & M_{a35} & 0 \\ 0 & M_{a42} & 0 & Mr_x^2 & 0 & 0 \\ M_{a51} & 0 & M_{a53} & 0 & Mr_y^2 + M_{a55} & 0 \\ 0 & 0 & 0 & 0 & 0 & Mr_z^2 \end{pmatrix} \quad (5)$$

where, M is the mass of the body, r_x , r_y , and r_z are the radii of gyrations about the x, y, and z-axes, respectively.

For more detail about the derivation of the mass matrix, refer to [1]

D. Structural Damping [C]

Damping was presented in the form of alpha and beta damping (Rayleigh Damping). The damping matrix [C] is calculated by using alpha and beta constants as multipliers to the mass matrix [M] and stiffness matrix [K], respectively.

$$[C] = \alpha[M] + \beta[K] \quad (6)$$

The values of α and β are calculated based on typical modal damping ratios, ζ .

E. Hydrodynamic Force Vector, {F(t)} on Square TLP

The problem of suitable representation of the wave environment or more precisely the wave loading is a problem of prime concern. Once the wave environment is evaluated, wave loading on the structure may be computed based on suitable theory. In this study the water particle position η is determined according to Airy's linear wave theory as following

$$\eta(x, t) = A_m \cos(kx - \omega t - \phi) \quad (7)$$

where A_m is the amplitude of the wave; k is the wave number; ω is the wave frequency; x is the horizontal distance from the origin; and ϕ is the wave phase angle. This description assumes a wave form which have small height, H , in comparison to its wave length, λ , and water depth, d . In order to incorporate the effect of variable submergence which is an important aspect of hydrodynamic loading on TLP, instantaneous sea surface elevation is taken as the still water level (or water depth). The fluctuating free surface effect can be significant when the wave height cannot be ignored compared to the water depth.

The hydrodynamic force vector is calculated in each degree of freedom according to modified Morison's equation which takes into account the relative velocity and acceleration between the structure and the fluid particles. It is also worth mentioning that the ratio d/H can be related to d/λ . Based on the limiting heights of breaking waves, it become unstable and break when $H/\lambda \geq 0.1$, (λ is the wave length).

$$dF = \left[\rho C_m A_s \left(\frac{du}{dt} - \frac{dx^*}{dt} \right) \right] + \left[\rho C_d D \left| U - \frac{dx}{dt} \right| \left(U - \frac{dx}{dt} \right) \right] - \left[(C_m - 1) \rho A_s \frac{dx^*}{dt} \right]$$

and,

$$U = u + \left(\frac{d+z}{d} U_c \right) \quad (8)$$

where A_s is the cross-sectional area; C_m is the inertia coefficient; U is the undisturbed fluid velocity; U_c is the current velocity, if exist; and C_d is the drag coefficient. Note that in (8), the first term represents the inertia force, the second term represents the drag force, and the last term represents the added mass force. The term $|U|$ is written in this form to ensure that the drag force

For the uni-directional wave train in the surge direction, the force vector $\{F(t)\}$, is given by

$$F(t) = \{F_{11} \quad F_{21} \quad F_{31} \quad F_{41} \quad F_{51} \quad F_{61}\}^T \quad (9)$$

Since the wave is unidirectional, there would be no force in the sway degree-of-freedom F_{21} and hence there will be no moment in the roll degree of-freedom F_{41} . Because of the vertical water particle velocity and acceleration, the heave degree-of-freedom would experience wave force F_{31} . The force in the surge direction F_{11} on the vertical members will cause moment in the pitch degree-of-freedom F_{51} . However, forces in the surge degree-of-freedom are symmetrical about the X axis (due to the symmetry of the platform to the approaching wave) and there will be no net moment caused in the yaw degree-of-freedom F_{61} .

F. Solution of the Equation of Motion in the Time Domain

The equation of motion is coupled and nonlinear and can be written as

$$[M]\{x''(t+\Delta t)\} + [C]\{x'(t+\Delta t)\} + [K]\{x(t+\Delta t)\} = \{F(t+\Delta t)\} \quad (10)$$

Equation (10) is nonlinearly coupled, because of the presence of structural displacement, velocity and acceleration in the right hand side of the equation. Therefore, the force vector should be updated at each time step to account for the change in the tether tension. To achieve this response variation a time domain analysis is carried out. The Newmark's beta time integration procedure is used in a step wise manner. This procedure was developed by Newmark together with a family of time-stepping methods. The following values are updated

- 1) Stiffness coefficients which vary with tether tension.
- 2) Added mass which varies with sea surface fluctuations.
- 3) Wave forces at the instantaneous position of the displaced structure.

IV. RESULTS AND DISCUSSION

A numerical scheme was developed using MATLAB software where solution based on Newmark's beta method was obtained. The geometric properties of the TLP and the hydrodynamic data considered for force evaluation are given in Table I.

Table II shows the coupled natural time periods of the structure in such case. It is observed that TLPs have natural periods of motion in the horizontal plane are high, whereas in

the vertical plane the periods are low. Generally, the surge and sway motions are predominantly high for head seas due to the combined actions of wind, waves and currents. However, due to coupling among various degrees of freedom and relatively low damping of hydrodynamic origin in the vertical plane motion, a complete analysis of a six degree-of-freedom system subjected to wind, waves and currents is desirable. Moreover, the structural flexibility in the horizontal motions causes nonlinearity in the structural stiffness matrix because of large deformations.

The natural periods in vertical plane in heave, roll and pitch are observed to be in the range of 1 to 3 seconds which is consistent with typical TLP's. While this range is below the periods of typical storm waves, everyday waves do have some energy in this range (the lowest wave period for most geographical locations is about 3 seconds). Thus, wave-excited vibrations can cause high-cycle fatigue of tethers and eventually instability of the platform. One alternative to this problem is to increase the moored stiffness as to further lower the natural periods in heave, roll and pitch movement. The other alternative is to install damping devices in the tethers to mitigate vertical motion.

It is observed that the tether length is directly proportional to the natural time period and that because of any increase in tether tension leads to decrease in the tether stiffness.

Time histories of the coupled responses are shown in Figs. 3 to 14. Before going into detailed discussion for each response it is clear from the figures that the tether length affects the drift value of the displaced position in the surge direction as the tether length increase the value of the drift increase.

TABLE I
GEOMETRIC PROPERTIES OF THE SQUARE TLP AND LOAD DATA

Water properties	
Gravity acceleration (m/sec ²)	9.81
Water weight density (kN/m ³)	10.06
Inertia coefficient, C_m	1.7
Drag coefficient, C_d	0.7
Current velocity (m/sec), U_c	0
Wave period (sec), T_w	10 and 15
Wave height (m), H_w	8 and 10
Platform properties	
Platform weight (KN), W	330000
Platform length (m), $2a$	75.66
Platform width (m), $2b$	75.66
Platform radius of gyration in x-directions (m), r_x	35.1
Platform radius of gyration in y-directions (m), r_y	35.1
Platform radius of gyration in z-directions (m), r_z	42.4
Tether total force (KN), T	135500
Tether area (m ²)	0.49
Draft (m)	29.9
Tether modulus of elasticity (kn/m ²), E	2.1e7
Diameter of columns (m), D_c	14
Diameter of pontoon (m), D_p	12
Center of gravity above the keel (m), h	27.47
Water depth (m), d	275,550 and 1100
Damping ratio, ζ	0.02

TABLE II
 CALCULATED NATURAL STRUCTURAL PERIODS FOR DIFFERENT ANALYSIS
 CASES (IN SECONDS)

DOF	Analysis Case		
	Water depth of 275 m	Water depth of 550 m	Water depth of 1100 m
Surge	63.7196	92.820	133.1401
Sway	63.7196	92.820	133.1401
Heave	1.1210	1.6296	2.3279
Roll	1.0219	1.483	2.1112
Pitch	1.01219	1.483	2.1112
Yaw	51.0887	74.4208	106.7485

A. Surge Response

The time histories of the surge responses for the square TLP are shown in Figs. 3 to 6. It is observed that, for a specific wave period, the amplitude of oscillations increases as the wave height increases. For short period the system responds in small amplitude oscillations about a displaced position that is directly proportional to wave height. The amplitude of oscillations increases with the increase in the wave period, which is expected because as the wave period increases, it becomes closer to the surge natural period of vibration (about 100 sec.). Moreover, in all cases, the surge response seems to have periodic oscillations that have the same exciting wave period.

The effect of tether length is obvious in Figs. 3 to 6 which indicate that it affect the drift value of the displaced position. As length becomes bigger the drift increases but the length of the tethers has little effect on the amplitude of the oscillation. Finally, the transient state takes about 40-150 seconds where the stationary state begins depends on the wave period as wave period increase it increases.

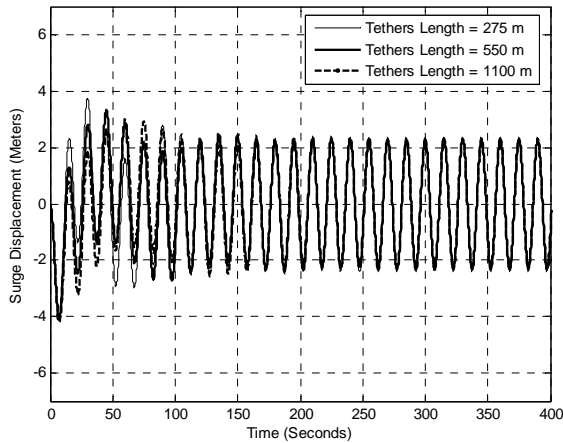

Fig. 3 Coupled Surge response of square TLP for Wave Height = 8 m and wave period = 15 sec

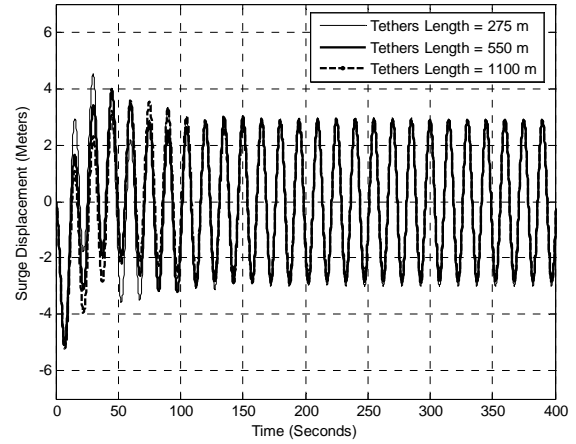

Fig. 4 Coupled Surge response of square TLP for Wave Height = 10 m and wave period = 15 sec.

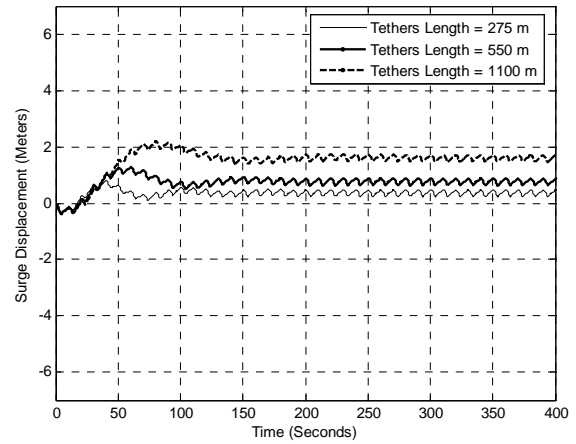

Fig. 5 Coupled Surge response of square TLP for Wave Height = 8 m and wave period = 10 sec

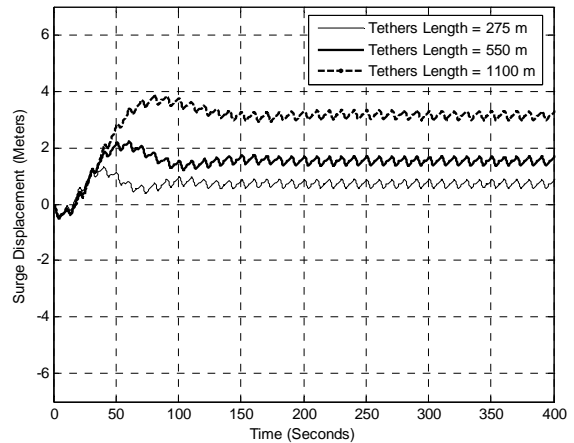

Fig. 6 Coupled Surge response of square TLP for Wave Height = 10 m and wave period = 10 sec

B. Heave Response

The time histories are shown in Figs. 7 to 10. As expected, the response in the heave direction has very small values compared to that of the surge direction. This is attributed to

the relatively high stiffness of the tethers in this direction together with the fact that the excitation is indirect in this case. Moreover, the heave response is inversely proportional to the wave period and directly proportional- but to a less extent- to wave height. The heave response appears to have a mean value of nearly zero. It is obvious that the increase of tether length increase the amplitude of the heave response. Also, the transient state takes about 10 seconds where the stationary state begins and the motion is almost periodic.

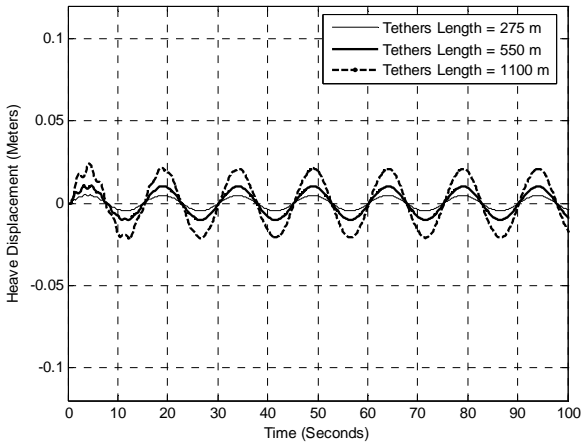

Fig. 7 Coupled Heave response of square TLP for Wave Height = 8 m and wave period = 15 sec

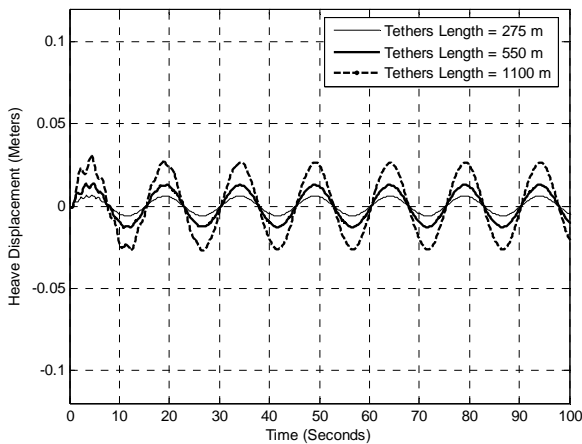

Fig. 8 Coupled Heave response of square TLP for Wave Height = 10 m and wave period = 15 sec

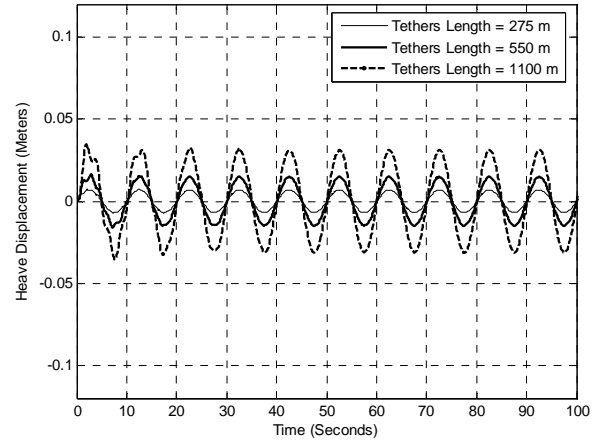

Fig. 9 Coupled Heave response of square TLP for Wave Height = 8 m and wave period = 10 sec

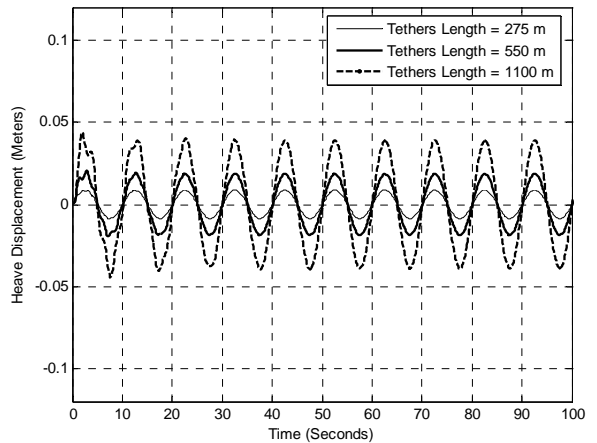

Fig. 10 Coupled Heave response of square TLP for Wave Height = 10 m and wave period = 10 sec

C. Pitch Response

The time histories shown in Figs. 11 to 14 it is clear that as the wave period increases the response becomes closer to being periodic in nature. For short wave periods (10 sec.), a higher mode contribution to the response appears to take place. For long wave periods (15 sec.), the higher mode contribution vanishes after one or two cycles and we have a one period response (wave period) as in the surge and heave cases. It is obvious that the increase of tether length increase the amplitude of the pitch response and that effect is more obvious for small wave period. Also the tether length affect the transient stat time. The time of the transient state increases as the tether length increase. Moreover, the transient state takes about 20-40 seconds before the stationary state begins.

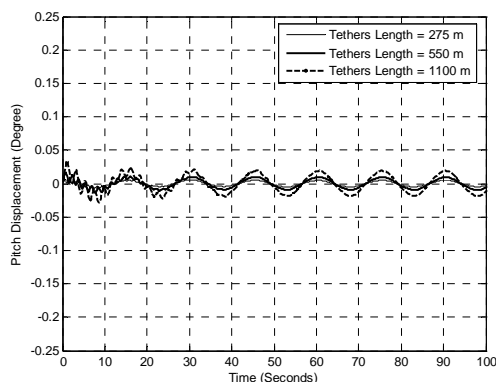

Fig. 11 Coupled Pitch response of square TLP for Wave Height = 8 m and wave period = 15 sec

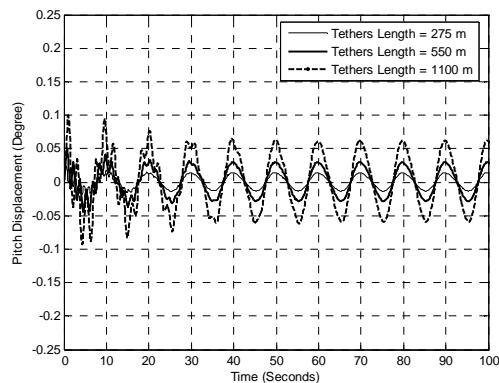

Fig. 14 Coupled Pitch response of square TLP for Wave Height = 10 m and wave period = 10 sec

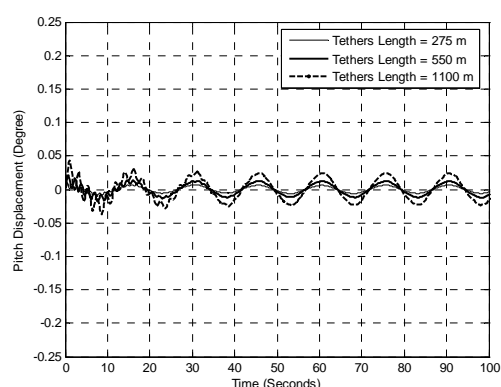

Fig. 12 Coupled Pitch response of square TLP for Wave Height = 10 m and wave period = 15 sec

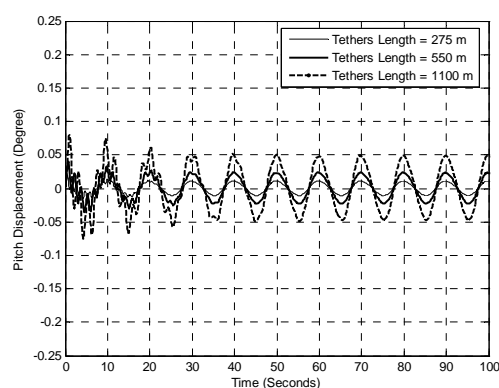

Fig. 13 Coupled Pitch response of square TLP for Wave Height = 8 m and wave period = 10 sec

V. CONCLUSIONS

The present study investigates the dynamic response of a square TLP under hydrodynamic forces in the surge direction considering all degrees of freedom of the system. A numerical dynamic model for the TLP was written where Morison's equation with water particle kinematics using Airy's linear wave theory was used. The scope of the work was to accurately model the TLP system considering added mass and nonlinearity in the system together with the coupling between various degrees of freedom. Results for the time histories for the affected degrees of freedom have been presented. Based on the results shown in this paper, the following conclusions can be drawn:

- 1) The natural periods of the horizontal plane motions (60 to 140) are higher than typical wave spectral peaks (8 to 15) which precludes resonance with the wave diffraction forces. However, the wave-induced low frequency forces, namely the wave drift forces, could be close (to some extent) to the natural periods of motion in the horizontal plane causing a significant response of a TLP despite the low amplitude of these forces. The maximum TLP response at low frequencies in various extreme environmental conditions is of primary importance from the point of view of platform stability, serviceability and fatigue of tethers.
- 2) The tether length is directly proportional to the natural time period of TLP. And that because of any increase in tether tension leads to decrease in the tether stiffness.
- 3) The surge displaced position increased as tether length increase while the amplitude is slightly affected.
- 4) The surge response oscillations about a displaced position that directly proportional to wave height and tether length.
- 5) The amplitude of surge oscillations increases with the increase in the wave period.
- 6) The heave response is inversely proportional to the wave period and directly proportional to wave height.
- 7) The heave response is directly proportional to the tether length.
- 8) The Pitch response is directly proportional to the tether length and that effect is more obvious for small wave period.

REFERENCES

- [1] A. M. Abou-Rayhan, Ayman A. Seleemah, and Amr R. El-gamal, "Wave induced motions of a squared tension leg platform in deep waters", *Al-Azhar University Engineering Journal*, Vol. 5, No. 1, DEC 2010, pp. 340-360.
- [2] Bhattachatya, S.K., Anitha, J., Idichandy, V.G., "Experimental and numerical study of coupled dynamic response of a mini-tension leg platform", *Journal of Offshore Mechanics and Arctic Engineering*, 126(4), 2004, pp.318-330.
- [3] Chandrasekaran, S. and Roy, A., "Phase space study of offshore structures subjected to non-linear hydrodynamic loading", *Proceedings of the International Conference on Structural Engineering*, Indian Institute of Science, Bangalore, SEC 2005.
- [4] Chandrasekaran, S., Jain, A. K., Gupta, A., Srivastava, A., "Response behaviour of triangular tension leg platforms under impact loading", *Ocean Engineering*, Vol. 34, 2007, pp.45-53.
- [5] Chandrasekaran, S., Jain, A. K., Gupta, A., "Influence of wave approach angle on TLP's response", *Ocean Engineering*, Vol. 34, 2007, pp. 1322-1327.
- [6] Ketabdari, M. J. and Ardakani, H. A., "Nonlinear response analysis of a sea star offshore tension leg platform in six degrees of freedom", *WIT Transactions on the Built Environment* 84,2005.
- [7] Kurian, V.J., Gasim, M.A., Narayanan, S.P., Kalaikumar, V., "Parametric Study of TLPs Subjected to Random Waves", *ICCBT-C-19*, pp. 213-222, 2008.
- [8] Kurian, V.J., Gasim, M.A., Narayanan, S.P., Kalaikumar, V., "Response of Square and Triangular TLPs Subjected to Random Waves", *ICCBT-C-12*, 2008, pp. 133-140.
- [9] Low, Y. M., "Frequency domain analysis of a tension leg platform with statistical linearization of the tendon restoring forces", *Marine Structures*, Vol. 22, 2009, 480-503.