

Reflection Performance of Truncated Pyramidal and Truncated Wedge Microwave Absorber Using Sugarcane Bagasse (SCB)

Liyana Zahid, Mohd Fareq Abd Malek, Ee Meng Cheng, Wei Wen Liu, Yeng Seng Lee, Muhammad Nadeem Iqbal, Fwen Hoon Wee, Farrah Salwani Abdullah

Abstract—One of the parameters that affect the performance of microwave absorbers is the shape of the absorbers. This paper shows the performance (reflection loss) of truncated pyramidal and truncated wedge microwave absorbers in the range frequency between 8.2 to 12.4 GHz (X-Band) in simulation. The material used is sugarcane bagasse (SCB) which is one of the new materials that used to fabricate the microwave absorber. The complex permittivity was measured using Agilent dielectric probe technique. The designs were simulated using CST Microwave Studio Software. The reflection losses between these two shapes were compared.

Keywords—Microwave Absorber, Reflection Loss, Sugarcane Bagasse (SCB), X- Band.

I. INTRODUCTION

MICROWAVE absorbers are the main components in anechoic chamber. They are used in testing scopes either in telecommunication, automotive and military [1]-[4]. Agricultural wastes such as sugarcane bagasse (SCB), rice husk and oil palm ash which contain carbon, have the potential to be used in fabricating the microwave absorber [5], [6]. Sugarcane (*Saccharum officinarum*) bagasse is a residue produced in large quantities by sugar industries. Sugarcane bagasse has the potential for being used as an alternative material in fabricating the microwave absorbers used in anechoic chamber to eliminate reflected signal [7]. The content of carbon that occurs naturally in sugarcane bagasse can provide good reflection loss performance. Elemental analysis of raw sugarcane bagasse using scanning electron microscope (SEM) showed that the content of carbon in sugarcane bagasse is 17.89% [8]. Carbon is one of the main elements that helped to absorb the microwave signal. Many shapes had been developed in fabricating the microwave absorber such as pyramidal [9] truncated [10], wedges [11], and multi-layer flat shapes [12].

L. Zahid, M. N. Iqbal, Y. S. Lee, and F. H. Wee are with the School of Computer and Communication Engineering, Universiti Malaysia Perlis, 02600 Perlis, Malaysia (email: liyanazahid@yahoo.com, mr.nadeemiqbal@gmail.com, weefwenhoon@gmail.com, leeyengseng@gmail.com).

M. Fareq and F. Salwani are with the School of Electrical Systems Engineering, Universiti Malaysia Perlis, 02600 Perlis, Malaysia. (e-mail: mfareq@unimap.edu.my, farrahsalwani@unimap.edu.my).

E. M. Cheng is with the School of Mechatronic, Universiti Malaysia Perlis, 02600 Perlis, Malaysia (e-mail: emcheng@unimap.edu.my).

W. W. Liu is with the Institute of Nano Electronic Engineering (INEE), Universiti Malaysia Perlis, Perlis Malaysia (email: wwliu@unimap.edu.my)

II. MATERIAL AND METHOD



Fig. 1 Ground sugarcane bagasse

Fig. 1 shows the raw material used which is sugarcane bagasse. Fig. 2 shows the work flow of this project.

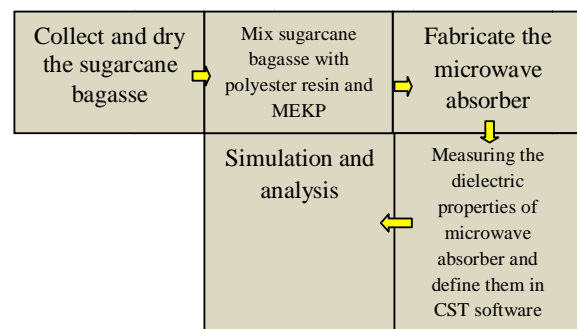

Fig. 2 Work flow

III. DIELECTRIC PROPERTIES

When a material has the ability to store energy when an external electric field is applied, it is classified as dielectric. The complex dielectric constant consists of real part which represents the storage and the imaginary part which represents of loss [13]. In this work, the dielectric properties of microwave absorber using sugarcane bagasse were measured using the Agilent Dielectric Probe Technique. Fig. 3 shows the measurement of dielectric properties using a dielectric probe.



Fig. 3 Defining dielectric properties using dielectric probe

Fig. 4 shows the average values of dielectric constant for SCB using the dielectric probe measurement technique. The average dielectric constant of the SCB was 1.44. The average loss tangent for SCB was 0.161.

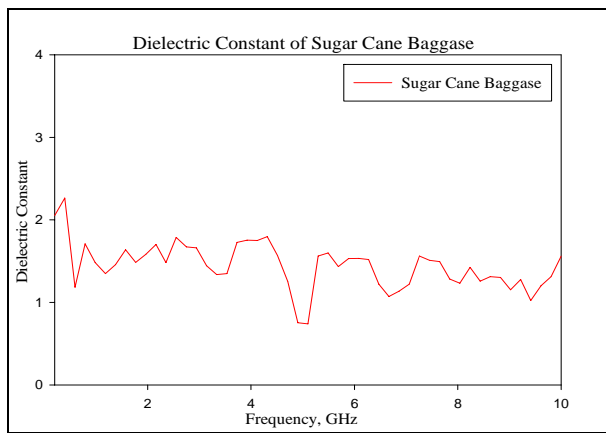

Fig. 4 Dielectric constant of sugarcane bagasse using the dielectric probe measurement technique

IV. DESIGNING THE MICROWAVE ABSORBER

A. Truncated Pyramidal Microwave Absorber

The truncated pyramidal has the basic shape of pyramidal but the change is only at the top of the pyramidal. There is a flat surface on top of the pyramidal shape. In this simulation, the metal back plate needed to be placed behind the absorber so that the signal can be reflected and absorbed by the sample absorber. Fig. 5 and Table I show the dimension of truncated pyramidal microwave absorber designed in CST Microwave Studio Software.

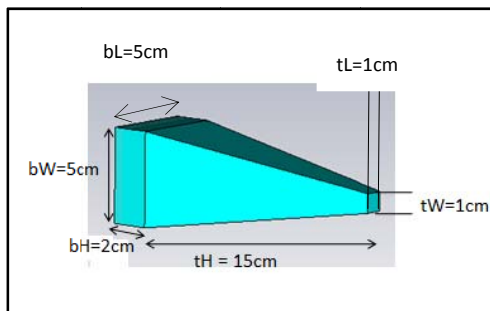

Fig. 5 Design of truncated pyramidal microwave absorber

TABLE I
 DIMENSIONS OF TRUNCATED PYRAMIDAL MICROWAVE ABSORBER

| Part | Symbols | Dimensions (cm) |
|-------------|---------|-----------------|
| | | Pyramid |
| Top Width | t_w | 1 |
| Top Length | t_L | 1 |
| Top Height | t_H | 15 |
| Base Width | b_w | 5 |
| Base Length | b_L | 5 |
| Base Height | b_H | 2 |

B. Truncated Wedge Microwave Absorber

Fig. 6 and Table II show the dimensions of truncated wedge microwave absorber designed in CST Microwave Studio Software.

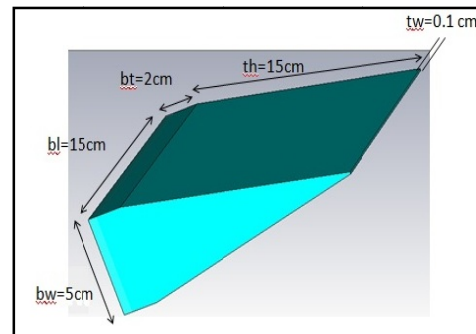

Fig. 6 Design of truncated wedge microwave absorber

TABLE II
 DIMENSIONS OF TRUNCATED WEDGE MICROWAVE ABSORBER

| Part | Symbols | Dimensions (cm) |
|----------------|---------|-----------------|
| | | Pyramid |
| Top Width | t_w | 0.1 |
| Top Length | t_L | 15 |
| Top Height | t_H | 15 |
| Base Width | b_w | 5 |
| Base Length | b_L | 15 |
| Base Thickness | b_t | 2 |

V. RESULTS AND DISCUSSION

A. Truncated Pyramidal Microwave Absorber

The average point of reflection loss over a range of frequency can determine the performance of microwave absorber. In this work, the range frequency used is in between 8.2 – 12.4 GHz. The result of reflection loss for truncated pyramidal microwave absorber using sugarcane bagasse in simulation is shown in Fig. 7 and Table III. Three different height of the truncated pyramidal were being tested, i.e., 10cm, 15cm and 20cm.

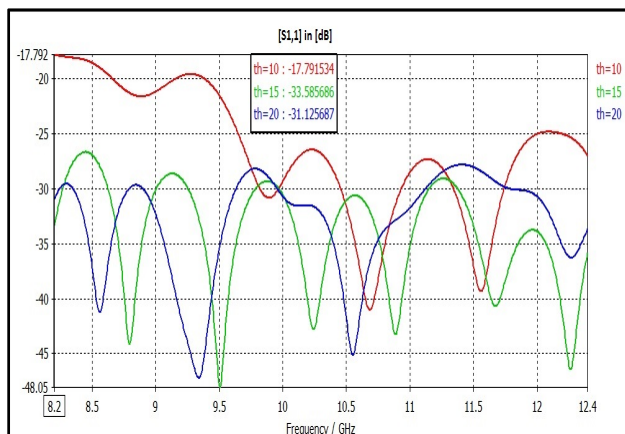

Fig. 7 Reflection loss for different top height (t_h) of truncated pyramidal microwave absorber

TABLE III
AVERAGE S11 PERFORMANCE OF TRUNCATED PYRAMIDAL MICROWAVE ABSORBER USING DIFFERENT TOP HEIGHT, T_h

| Frequency (GHz) | Average [S11] in dB with different top height(t_h) (Simulation) | | |
|-----------------|---|-------------|-------------|
| | $t_h=10$ cm | $t_h=15$ cm | $t_h=20$ cm |
| 8.2 – 12.4 | -26.47 | -34.12 | -33.11 |
| Best point | -41.02 | -48.05 | -47.13 |

From the graph, the best average reflection loss is when the pyramid height is 15cm which is 34.12 dB compared to average reflection loss when the pyramidal heights were 10cm and 20cm which showed 26.47 dB and 33.11 dB respectively. The best reflection loss for the pyramid height of 15cm from the base is 48.05 dB at the frequency of 9.50 GHz.

B. Truncated Wedge Microwave Absorber

The result of reflection loss for truncated wedge pyramidal microwave absorber using sugarcane bagasse in simulation is shown in Fig. 8 and Table IV. Three different length of the truncated wedge's base were being tested, i.e., 10cm, 15cm and 20cm.

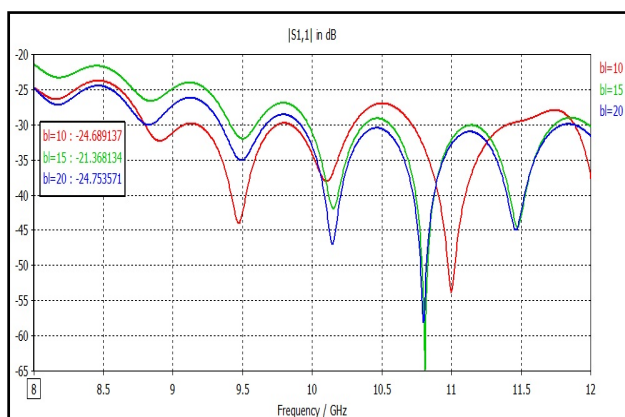

Fig. 8 Reflection loss for different base length of truncated wedge microwave absorber

TABLE IV
AVERAGE S11 PERFORMANCE OF TRUNCATED WEDGE MICROWAVE ABSORBER WITH DIFFERENT BASE LENGTH, B_L

| Frequency (GHz) | Average [S11] in dB with different Base Length(b_L) (Simulation) | | |
|-----------------|--|-------------|-------------|
| | $b_L=10$ cm | $b_L=15$ cm | $b_L=20$ cm |
| 8.2 – 12.4 | -31.28 | -29.90 | -31.82 |
| Best point | -53.0 | -56.07 | -54.11 |

From the graph, the best average reflection loss is when the base length is 20cm which is 31.82 dB compared to average reflection loss when the length of the wedge's bases were 10cm and 15cm which showed 31.28 dB and 29.90 dB respectively. The best point of reflection loss is when the base length of the truncated wedge is 15cm which is 56.07 dB at the frequency of 10.8 GHz. Based on the result, the reflection loss results obtained for the sugarcane bagasse pyramidal microwave absorbers are significantly better than 10 dB.

VI. CONCLUSION

Different shapes give different performance of microwave absorber. The results of this study showed that the shape of truncated pyramidal microwave absorber using the material of sugarcane bagasse gives better performance compare to truncated wedge microwave absorber in the range frequency between 8.2 – 12.4 GHz. This is because, the best reflection loss performance of microwave absorber is when the top height of truncated pyramidal is 15cm. From the results, sugarcane bagasse (SCB) can be used as the alternative material for fabricating microwave absorber. Besides, the cost of fabricating the microwave absorber using SCB is also less expensive than the commercialize microwave absorber. The usage of SCB as the new material can help save the nature by reducing the abundant of the residues produced by sugar industries.

ACKNOWLEDGMENT

Authors thank Universiti Malaysia Perlis and the Malaysian Ministry of Higher Education for funded this project under grant KTP 9011-00009.

REFERENCES

- [1] Zivkovic, I., Murk, A., Characterization of Magnetically Loaded Microwave Absorbers, *Progress In Electromagnetics Research B*, vol. 33, pp. 277-289, 2011.
- [2] Goudus, S. K., Sahalos, J. N., Microwave Absorber Optimal Design Using Multi-Objective Particle Swarm Optimization, *Microwave and Optical Technology Letters*, vol. 48, no. 8, pp. 1553-1558, 2006.
- [3] Iqbal, M. N., F. Malek, S. H. Ronald, M. Shafiq, K. M. Juni, and R. Chat, "A study of the EMC performance of a graded – Impedance, microwave, rice husk absorber," *Progress In Electromagnetic Research*, Vol. 131, 19-44, 2012.
- [4] Chung, B. -K. Chuah, H. -T., Modeling Of RF Absorber For Application InThe Design Of Anechoic Chamber, *Progress In Electromagnetics Research*, vol. 43, pp. 273–285, 2003.
- [5] Normikman, H., Malek, F., Ahmed, M., Wee, F. H., Soh, P. J., Azremi, A. A. H., Ghani, S. A., Hasnain, A., Taib, M. N., Setup and Results of Pyramidal Microwave Absorbers Using Rice Husks, *Progress in Electromagnetics Research (PIER)*, vol. 111, pp. 141-161, 2011.
- [6] Noordin, I.R.M., Idris, H.A., Taib, M.N., Sharif, J.M., Rosli, A.D., Zanal, A., Abdullah, A.T., Investigation of Oil Palm Ash Microwave Absorber for Broadband Application, 2012 IEEE 8th International

- Colloquium on Signal Processing and its Applications (CSPA), pp. 232-235, 2012.
- [7] Z.Liyana, F. Malek, H., Normikman, M, N. A. M. Affendi, A. Ali, N. Hussin, B. H. Ahmad, and M. Z. A. A. Aziz, "Development of Pyramidal Microwave Absorber using Sugar Cane Bagasse (SCB)," *Progress in Electromagnetics Research (PIER)*, vol. 137, pp. 687-702, 2013.
- [8] P. B. Devnarain, D. R. Arnold, S. B. Davis, Production of Activated Carbon from South African Sugarcane Bagasse, Proceedings Congress of the South African Sugar Technologists Association, Vol. 76, pp. 477 – 489, 2002.
- [9] A. Hasnain, B. M. Hafiz, S. Roslan, M. I. Imran, A. A. Takiyuddin, A. Rusnani, and O. M. Khusairi, "Development of an Economic and Effective Microwave Absorber," Asia-Pacific Conference on Applied Electromagnetics Proceedings, 2007.
- [10] Normikman, H., Ahmad, B. H., Abd Aziz, M. Z. A., Kamarudin, M. R., Effect of Spiral Split Ring Resonator (S-SRR) structure on Truncated Pyramidal Microwave Absorber Design, 2012 International Symposium on Antennas and Propagation (ISAP 2012), pp. 1188 – 1191, 2012.
- [11] Normikman, H., P. J. Soh, F. Malek, A. A. H. Azremi, F. H. Wee, and R. B. Ahmad, "Microwave wedge absorber design using rice husk -An evaluation on placement variation," 2010 Asia-Pacific International Symposium on Electromagnetic Compatibility (APEMC), 927-930, 2010.
- [12] F. Jia-Hui, W. Qun, Z. Shao-Qing, Z. Kuang and M. Fan-Yi, "Design of Multi-layers Absorbers for Low Frequency Applications," 2010 Asia-Pacific International Symposium on Electromagnetic Compatibility.
- [13] Agilent, Technologies Inc, (2006). Agilent Basics of Measuring the Dielectric Properties of Materials.