

# Close Loop Controlled Current Nerve Locator

H. A. Alzomor, B. K. Ouda, A. M. Eldeib

**Abstract**—Successful regional anesthesia depends upon precise location of the peripheral nerve or nerve plexus. Locating peripheral nerves is preferred to be done using nerve stimulation. In order to generate a nerve impulse by electrical means, a minimum threshold stimulus of current “rheobase” must be applied to the nerve. The technique depends on stimulating muscular twitching at a close distance to the nerve without actually touching it. Success rate of this operation depends on the accuracy of current intensity pulses used for stimulation. In this paper, we will discuss a circuit and algorithm for closed loop control for the current, theoretical analysis and test results is discussed and results is compared to previous techniques.

**Keywords**—Close Loop Control, Constant Current, Nerve Locator.

## I. INTRODUCTION

THE regional anesthesia is preferred to global anesthesia when applicable due to its advantages including safety, low cost and patient preference.

Historically, nerve blocks were performed using anatomical landmarks as a guide as to where to insert the needle and then eliciting paraesthesia. When the locating needle touched the nerve the patient experienced a sensation like ‘pins and needles’ or an ‘electric shock like sensation.

The disadvantages of using a paraesthesia technique are the theoretical increase in the risk of nerve damage by the needle touching the nerve, its reliance on a subjective sensation that patient experiences and the lack of an objective response that the anesthetist can use [1].

Nerve Locator is the most commonly used technique in most developed countries for locating peripheral nerves [2]. The technique depends on stimulating muscular twitching at a close distance to the nerve without actually touching it [3]. Successful regional anesthesia depends upon precise location of the peripheral nerve or nerve plexus [3].

In order to generate a nerve impulse by electrical means, a threshold stimulus of current must be applied to the nerve “rheobase” [2]. Further the needle tip is from the nerve, a proportionately greater current is needed to stimulate the nerve, and vice versa. Based on this fact, the amount of current and pulse duration required to stimulate the nerve indicates how far the needle tip from the nerve is. The load resistance varies with the tissue impedance and the position of the electrode from the tip of the needle. Current delivered to the nerve has to be maintained constant regardless of the tissue

impedance and the distance between the needle tip and the electrode.

## II. PREVIOUS WORK

Several implementations for generating a fixed current for nerve locator and stimulators were proposed before like using a current mirror with variable control voltage which achieves a relative error up 5% and lacks a closed loop control as in [4] or using operational amplifier with step up transformer for setting the current and operational amplifier for current feedback as in [5] or using a  $\mu$ -controller to drive 16 Bit Digital to Analog Converter "DAC" which its output is used to drive voltage to current converter circuit implemented with two operational amplifier as in [6]. Previous techniques suffer from bad current precision or lack of information about the current intensity accuracy.

## III. OUR PREVIOUS WORK

### A. Design Idea

In order to control the stimulating current, a controlled current sink circuit was developed [7]. The current sink circuit consists of a Pulse Width Modulation PWM signal with a duty cycle proportional to the required current and a low pass filter for converting the PWM to the DC voltage. An Operational Amplifier Op-Amp and Darlington transistor are used for buffering the DC voltage which is applied to high precision resistor to control the amount of sink current, a transistor is used to interrupt the current path in order to control the pulse width and frequency of the pulse. The PWM and interrupt resistor timings are generated using timer interrupts on the  $\mu$ controller. Circuit is shown in Fig. 1 and simulation result for the current against control Voltage is shown in Fig. 2.

H. A. Alzomor is with the Almanar for Electronic Systems, Cairo, Egypt (phone: +202-358-35215; e-mail: Hossam.alzomor@almanar.com.eg).

B.K. Ouda is with the Department of Faculty of Biomedical Engineering, Cairo University, Egypt (e-mail: bkouda@k-space.org).

A. M. Eldeib is with the Department of Faculty of Biomedical Engineering, Cairo University, Egypt (e-mail: eldeib@ieec.org).

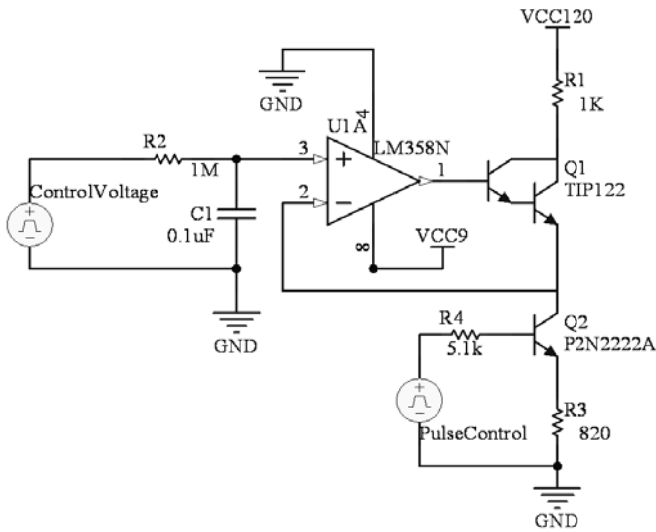

Fig. 1 Previous work current control circuit

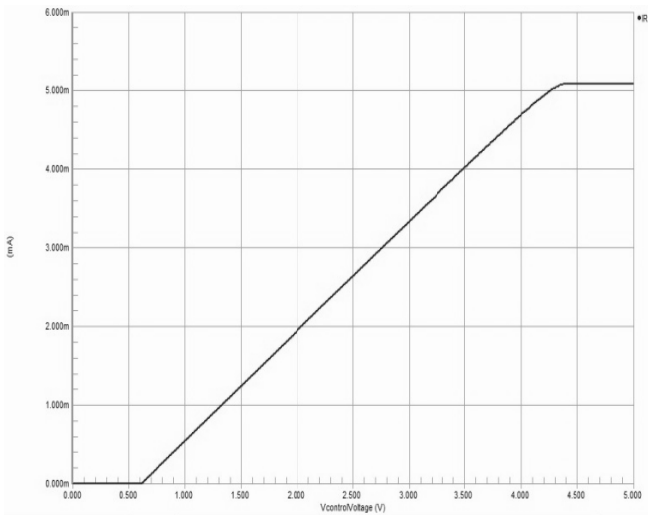

Fig. 2 The current following through load against control voltage

### B. Previous Work Mathematical Analysis

The current following in the load R1 is given by the following equation

$$I_{R1} = I_{R3} - I_{R4} \quad (1)$$

$$I_{R3} = \frac{V_{ControlVoltage} - V_{CEQ2}}{R_3} \quad (2)$$

$$I_{R4} = \frac{V_{PulseControl} - V_{BEQ2} - (V_{ControlVoltage} - V_{CEQ2})}{R_4} \quad (3)$$

from (1), (2), and (3)

$$I_{R1} = \frac{V_{ControlVoltage}(R_3 + R_4)}{R_3 R_4} - \frac{V_{CEQ2}(R_3 + R_4)}{R_3 R_4} - \frac{V_{PulseControl} - V_{BEQ2}}{R_4} \quad (4)$$

$V_{CEQ2}$  takes values from 0 to 0.2 Volts in saturation region.

$V_{PulseControl}$  is 5 Volts.

$V_{BEQ2}$  is 0.6 Volts.

$R_3$  is 820ohm.

$R_4$  is 5.1Kohm.

$$I_{R1} = 0.00141(V_{ControlVoltage} - V_{CEQ2}) - 0.00086 \quad (5)$$

at 1<sup>st</sup> step  $V_{CEQ2}$  is 0 Volts.

$$0 = 0.00141 * V_{ControlVoltage_{min}} - 0.00086$$

$$V_{ControlVoltage_{min}} = \frac{0.00086}{0.00141} = 0.6Volts$$

when  $I_{R1}=5mA$   $V_{CEQ2}$  is 0.2Volts.

$$0.005 = 0.00141 * V_{ControlVoltage_{max}} - 0.00141 * 0.2 - 0.00086$$

$$V_{ControlVoltage_{max}} = 4.356 Volts.$$

Control voltage dynamic range =  $V_{ControlVoltage_{max}} - V_{ControlVoltage_{min}} = 3.756$  Volts.

Voltage step =  $5/256 = 0.0195$  Volts.

Dynamic range steps =  $3.756/0.0195 = 192$  Steps.

Minimum current step =  $5mA/192 = 26\mu A$ .

### C. Previous Work Impairments

Current was controlled using open loop control circuit which is not capable of compensation for variations in component values with time and due to temperature change.

- 1) A 8 bit  $\mu$ -controller was used for generating the pulse width modulation PWM signal for voltage control which limits the resolution of the minimum current step.
- 2) Low resolution of minimum current step.

## IV. PROPOSED DESIGN

In order to overcome the impairments of the old design a new design was proposed with the following improvements

### A. Closed Loop Control

A closed loop control system was implemented by measuring the current following in the control resistor and use it to modify the PWM signal used to generate the control voltage. A high side current measurement is used instead of measuring the current following into the control resistor to take the base current of the pulse control transistor into consideration.

The correction action is done on two steps; the 1st time after setting the new current a correction value proportional to the error is added to the PWM and in the consecutive corrective steps one PWM step is added / subtracted from the previous PWM value for correction. This way the system locks to the desired value quickly and avoids oscillations for consecutive steps. A hysteresis is implemented to reduce oscillations by defining a threshold of error to start the correction process. Fig. 4 shows the flow chart for the feedback algorithm.

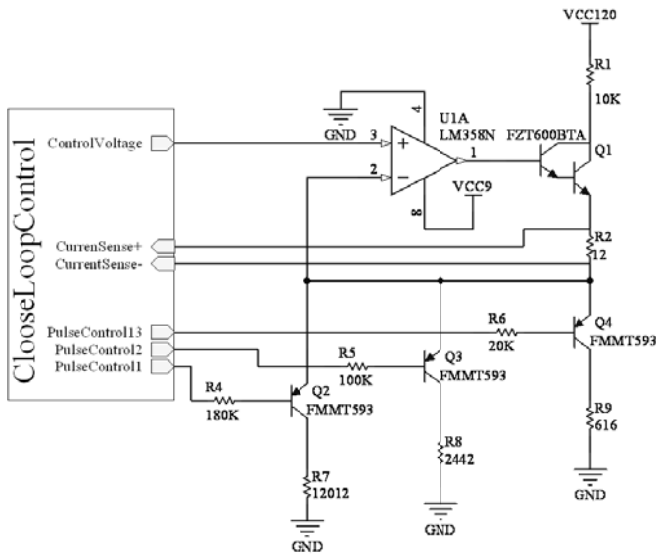

Fig. 3 Proposed Hi precision close loop current control system

**B. Hi Precision PWM Control**

A 32 bit  $\mu$ -controller was used for implementing the embedded program and 16 bit timer used for generating the voltage control PWM signal which allows high precision control voltage.

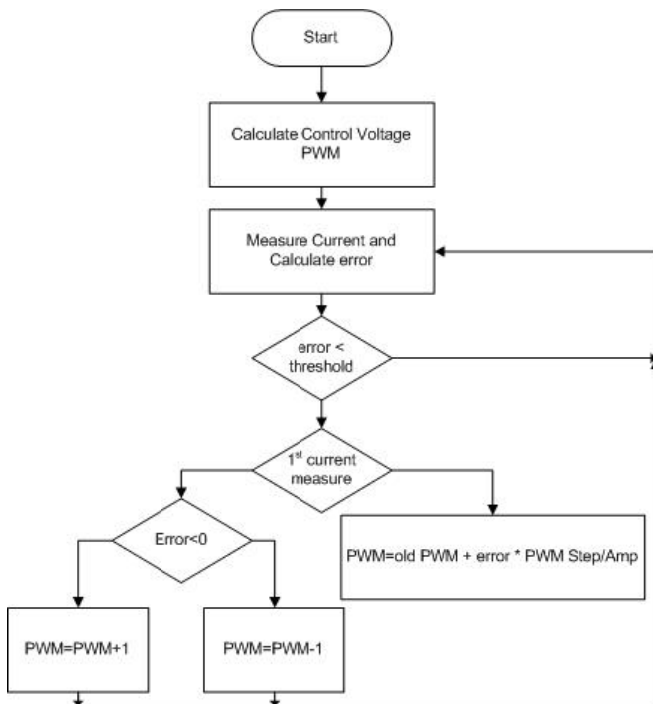

Fig. 4 Current close loop control

**C. High Resolution Current Step**

Low values of Current needs more precision than High values of current, for example an error of  $26\mu$ -Amp –the minimum current step- at 5mAmp is 0.52% while an error of  $26\mu$ -Amp at 50 $\mu$ -Amp is 52%, in order to increase the precision of current at low values the whole range from 0 to

5mAmp is controlled using 3 control circuits each of them is tuned with minimum current precision suitable to its range.

Fig. 3 shows the proposed design with feedback control circuit. The simulation results for the 3 current ranges are shown in Fig. 5.

**V. PROPOSED DESIGN MATHEMATICAL ANALYSIS**

Mathematical Analysis is done for Q4 in Fig. 3 while the same analysis is applicable for Q2 and Q3.

$$I_{R_1} = I_{R_6} + I_{R_9} \quad (6)$$

$$I_{R_1} = \frac{V_{ControlVoltage} - V_{ECQ4}}{R_9} + \frac{V_{ControlVoltage} - V_{EBQ4}}{R_6} \quad (7)$$

$V_{ECQ4}$  is about 0.06Volts and  $V_{EBQ4}$  is about 0.6Volts.

We calculated the start and stop control voltage, control Voltage range, current range, number of steps per each range and minimum current step for each range of the three ranges, results is shown in Table I.

The range of control voltage from 0 to 3.3 Volt is controlled using 19200 step Pulse width modulation.

The current range from 0 to 5mAmp is divided into three ranges and the control voltage for the beginning of the range and the end of each range is calculated, from dynamic range of the control voltage for each current range we calculated the number of control steps and min current step and the minimum precision ratio for each range which is the ratio between step current in that range to the minimum current value in that range.

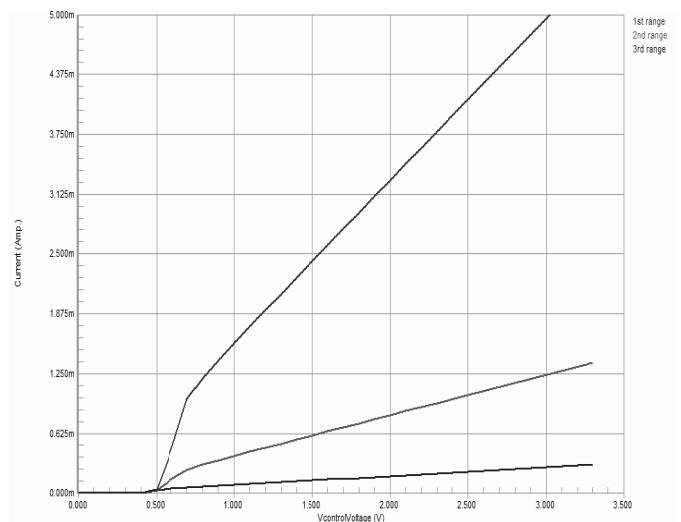

Fig. 5 Simulation results for the 3 current ranges

TABLE I  
CURRENT RANGES, CONTROL VOLTAGE RANGES AND MAX ERROR IN EACH RANGE

Control Voltage (Volt)	IR1 (Amp)	Vce (Volt)	Vbe (Volt)	Rc ( $\Omega$ )	Rb ( $\Omega$ )	Control Voltage Range (volt)	Current range (Amp)	number of voltage steps	Min. current step (Amp)	Min. Precision ratio in range %
0.656808949	0.00005	0.06	0.6	12012	180000					
2.908918193	0.00025	0.06	0.6	12012	180000	2.252109243	0.0002	13103	1.52637E-08	0.031%
0.788008825	0.0003	0.06	0.6	2442	100000					
3.171796724	0.0013	0.06	0.6	2442	100000	2.383787899	0.001	13869	7.21033E-08	0.024%
0.853007373	0.0013	0.06	0.6	616	20000					
3.064105549	0.005	0.06	0.6	616	20000	2.211098176	0.0037	12864	2.87624E-07	0.022%

## VI. PROPOSED DESIGN TESTING AND RESULTS

The current is measured through a calibrated high precision 10K $\Omega$  resistor using a 100MHz with 8 bit vertical resolution, results is shown in Table II.

TABLE II  
ERROR IN CURRENT

Set Current mAmp	Measured current mAmp	Error%
0.1	0.1	0%
0.3	0.298	0.8%
1	0.992	0.8%
2.5	2.52	0.8%
5	5	0%

The actual error is higher than the theoretical error showed in Table I because of the accuracy of the passive components used is 1%. Table III shows the measurements of the current in the proposed design compared with measured done on a wide range of the nerve locators available in the market [2].

TABLE III  
CURRENT INTENSITY IN THE PROPOSED DESIGN COMPARED TO DEVICES IN THE MARKET

	Target Current intensity, mAmp			
	5	1	0.3	0.1
Proposed Design	5	0.992	0.298	0.1
Stimplex HNS 12	5	0.99	0.3	0.1
MultiSim Vario	4.9	0.98	0.29	0.09
Plexival	4.9	0.98	0.3	0.11
Plexygon	4.9	0.98	0.29	0.09
Stimplex HNS 11	4.9	1.1	0.4	0.2
Multisem Sensor	5	0.98	0.3	0.1

The design is fabricated and tested at Faculty of Veterinary Cairo University on the superficial head nerves and deep limbs nerves of colt, and the process of nerves stimulation was successfully done. Device is currently being test at faculty if Medicine Cairo University. Picture for the device after assembly is shown in Fig. 6.



Fig. 6 Proposed design after assembly

## VII. CONCLUSION

A design was proposed to implement closed loop control for controlling the pulsating current of nerve locator, the whole current range is divided on three bands with different absolute current precision for each range to avoid high error ratio in current at low current values. The proposed design showed a significant improvement in current intensity accuracy against our previous design [7] and is comparable with the best Nerve locators in the market [2].

## ACKNOWLEDGMENT

The authors would like to thank the Egyptian information technology development authority ITIDA for funding the project and Prof. Mohamed Barakat for guiding the tests at Faculty of Veterinary.

## REFERENCES

- [1] Dr Anand M. Sardesai and Dr Uma Iyer, "Nerve Stimulation for Peripheral Nerve Blockade." ATOTW, 2009, #149 August ,PP 1-8.
- [2] D. Jochum , G. Iohom, D. P. Diarra, F. Loughnane, L. J. Dupre and H. Bouaziz, "An Objective assessment of nerve stimulators used for peripheral nerve blockade" Anaesthesia, 2006, 61, PP 557-564.
- [3] Phil Dalrymple and Subbiah Chelliah "Electrical Nerve Locators", British Journal of Anaesthesia, 2006, Volume 6 Number 1, PP 32-36.
- [4] Jader A. De Lima and Adriano S. Cordeiro, "A Low-Cost Neurostimulator with Accurate Pulsed-Current Control", IEEE Transactions on Biomedical Engineering, vol. 49, no. 5, May 2002, pp. 497-500.
- [5] K. W. Eric Cheng, Yan Lu, Kai-Yu Tong, A. B. Rad, Daniel H. K. Chow, and Danny Sutanto, "Development of a Circuit for Functional

- Electrical Stimulation” *IEEE Transactions on Neural Systems And Rehabilitation Engineering*, vol. 12, No. 1, March 2004 pp 43-47.
- [6] Subaryani D H Soedirdjo, Mervin T Hutabarat, “Microcontroller-based Transcutaneous Electrical Nerve Stimulator with 8 Bit Cascade DAC” International Conference on Instrumentation, Communications, Information Technology, and Biomedical Engineering (ICICI-BME), 2009 pp1-5.
- [7] H. A. Alzomor, B. K. Ouda “Low Cost, Compact and Pulsated Constant Current Microcontroller Based Nerve Locator” Cairo 6th International Biomedical Engineering Conference, Dec. 2012, pp. 87–90.