

DC Bus Voltage Regulator for Renewable Energy Based Microgrid Application

Bakari M. M. Mwinyiwiwa

Abstract—Renewable Energy based microgrids are being considered to provide electricity for the expanding energy demand in the grid distribution network and grid isolated areas. The technical challenges associated with the operation and controls are immense. Electricity generation by Renewable Energy Sources is of stochastic nature such that there is a demand for regulation of voltage output in order to satisfy the standard loads' requirements. In a renewable energy based microgrid, the energy sources give stochastically variable magnitude AC or DC voltages. AC voltage regulation of micro and mini sources pose practical challenges as well as unbearable costs. It is therefore practically and economically viable to convert the voltage outputs from stochastic AC and DC voltage sources to constant DC voltage to satisfy various DC loads including inverters which ultimately feed AC loads. This paper presents results obtained from SEPIC converter based DC bus voltage regulator as a case study for renewable energy microgrid application. Real-Time Simulation results show that upon appropriate choice of controller parameters for control of the SEPIC converter, the output DC bus voltage can be kept constant regardless of wide range of voltage variations of the source. This feature is particularly important in the situation that multiple renewable sources are to be integrated to supply a microgrid under main grid integration or isolated modes of operation.

Keywords—DC Voltage Regulator, microgrid, multisource, Renewable Energy, SEPIC Converter.

I. INTRODUCTION

WORLDWIDE, about 1.5 billion people live without access to electricity. Without a concerted effort, the number of people denied from electricity supply is likely to sustain or even increase [1]. Extension of National Grids is often prohibited by high cost and non feasible in isolated rural areas [1], [2]. Solutions to the limitations of rural energy access around the world require the use of both centralised and decentralised power systems [1], [2]. In 2010, the International Energy Agency estimated that, “to achieve universal access to electricity, 70% of the rural areas that currently lack access will need to be connected using mini-grid or off-grid decentralised solutions” [3]. Mini-grids and other decentralised solutions may be more attractive than large, centralised solutions in rural areas for the following reasons [3]-[6].

Worldwide, in the effort to meet the current and ever growing energy demand there is an increasing adoption of distributed generation (DG) in the form of Renewable Energy Sources (RES) that form minigrid and/or microgrids [7]-[9]. In this direction, many issues related to economics, electrical system optimization and long-term viability have been focused and researched. The control of

dc-dc voltage regulator and inverter interfaced microgrid network that combines diversity of RES is the structure tackled by this research work. This research focuses on integration and control of RES microgrid where, architecture and controller for dc-dc converter and dc-ac inverter interfaced microgrid is envisaged. This particular focus on renewable energy research has been motivated by unavailability of electricity in grid isolated areas (mainly rural areas) while there are various electrification options from locally available and plenty diversity of unexploited RES.

The proposed microgrid architecture extends the traditional integration use of solar and wind generation systems to include other diversity of RES such as solar, mini/micro hydro generation, biofuel generation, biomass, biogas and oceanic (waves and tides) generation instead of fossil fuels to increase power density and maintaining reliability, sustainability and also protect the environment.

As part of continuous research, this paper presents a design example of DC bus voltage regulator which is mandatory for integration of diverse envisaged electricity sources with stochastic outputs. The DC bus voltage regulators in this case are used to maintain a DC bus voltage at constant value and therefore used as a point of common coupling of several available renewable energy sources. The DC voltage common bus is proposed in this paper due to its simplicity to control as compared to AC voltage common bus which needs complex control aspects to achieve synchronisation and stable operation.

II. PROPOSED MICROGRID SYSTEM WITH MULTIPLE RENEWABLE ENERGY SOURCES

The general configuration of the proposed microgrid system consists of several renewable energy sources whose generation is assumed to be stochastic in nature. The emphasis here is that taking a typical situation where one or two or even three of the available renewable sources cannot reliably supply the connected load continuously. In order to enhance power supply reliability using renewable energy based microgrid, there is a need to integrate many and diversified renewable energy sources which are available and easily developed in the area of consideration.

Fig. 1 shows the proposed system of an inverter interfaced microgrid which is supplied by several renewable energy sources interfaced using an envisaged DC Voltage busbar. As it can be seen in Fig. 1, the microgrid is configured to supply DC loads and AC loads. In addition, the microgrid can also exchange power with the available nearby Main Grid (National Grid) in order to further enhance reliability of the system.

With the proposed microgrid configuration shown in Fig. 1, when failures occur in the main grid system, the

Bakari M. M. Mwinyiwiwa is with the Department of Electrical Engineering, College of Engineering and Technology, University of Dar es Salaam, Tanzania (e-mail: bakari_mwinyiwiwa@yahoo.com).

microgrid is automatically transferred to isolated islanding operation to supply the connected local load. Seamless transition between the interconnected to the islanding mode of operation is crucial to uninterrupted continuity of supply to the local load of the microgrid.

In Fig. 1, the net dc bus power (P_{dc}) is determined by the sum of all connected microsources to the respective bus. The accumulation involves power from all available sources and the storage system (P_s). The total power at the DC busbar for n available energy sources and storage system is given as,

$$P_{dc} = \sum_{i=1}^n (P_{dc}(i)) \pm P_s \quad (1)$$

where, $P_{dc}(i)$ is the i^{th} DG connected to the regulated Voltage DC busbar.

The DC bus power remains after consumption by some local DC loads, is converted to AC by the inverter to feed load \bar{S}_1 at a standard AC load voltage, \bar{V}_1 . The apparent power at the inverter output is given as

$$\bar{S} = P + jQ \quad (2)$$

with load angle of ϕ , the active and reactive power of the load are respectively given in (3) and (4).

$$P = S (\cos \phi) \quad (3)$$

$$Q = S (\sin \phi) \quad (4)$$

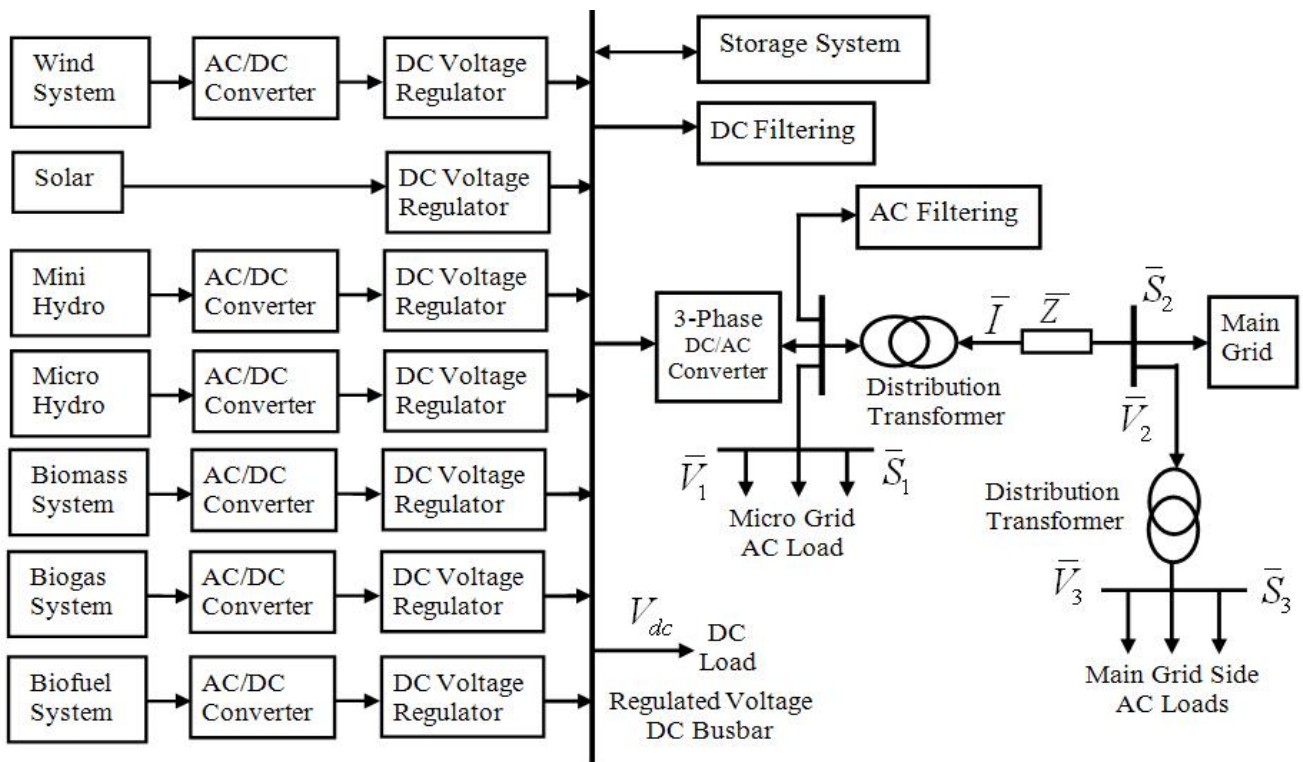

Fig. 1 Configuration of the multisource microgrid [8]

In (2) through (4) both resistances and reactances are taken into consideration during analysing and tuning various controller parameters for the microgrid in contrast to previous designs where resistance is usually neglected. Maintaining stability and power quality in the islanding mode of operation requires the development of sophisticated control strategies and need to include both generation and demand sides. In a good quality power network there must be a match between supply and demand at any particular point of time, where power balance in (5) has to be applied.

$$\sum_{i=1}^n P_{S,i} + \sum_{i=1}^n Q_{S,i} = \sum_{j=1}^m P_{L,j} + P_R + \sum_{j=1}^m Q_{L,j} + Q_X \quad (5)$$

where n and m represents number of micro-sources and loads connected at the microgrid respectively, $P_{S,i}$, $P_{L,j}$ and P_R represent supplied and consumed active power, active power due to load and network resistive losses. On the other hand, $Q_{S,i}$, $Q_{L,j}$ and Q_X represent supplied and consumed reactive power due to connected load and network reactance.

The proposed overall control strategy is anticipated to improve the stability and power quality of isolated microgrids and grid distribution based microgrid with greater penetration of DG at remote locations. A total voltage harmonic distortion (THD) of not greater than 5% as set by IEEE standard 519-1992 is also a target in this research work.

III. REVIEW OF THE METHODOLOGIES FOR DC VOLTAGE REGULATION USING DC-DC CONVERTERS

Various types of DC-DC converters have been researched and can be readily used for DC Voltage regulation [10], [11]. The well known DC-DC converters are Buck, Boost, Buck-Boost and Cuk Converters. Single-Ended Primary Inductor Converter (SEPIC) which has emerged in recent years is increasingly gaining popularity [12]-[14]. The Buck-Boost and Cuk converters have similar characteristics that the output voltage can be higher or lower than the input voltage. Also these two types of converters reverse the voltage polarity between input and output. However, SEPIC converter can boost and buck the input voltage and it can also maintain the polarity between input and output. Maintenance of voltage polarity between input and output is particularly of interest in renewable energy applications such as battery charging.

Fig. 2 shows a circuit diagram of SEPIC converter. The details of analysis, modeling and duty cycle control are well covered in [12]-[14]. The governing operational relationships between inputs and outputs, assuming lossless system, are given by (6) through (8):

$$P_{in} = P_{out} \quad (6)$$

$$V_o = \left(\frac{D}{1-D} \right) V_{in} \quad (7)$$

$$I_o = \left(\frac{1-D}{D} \right) I_{in} \quad (8)$$

where P_{in} is input power, P_{out} is output power, V_{in} is input voltage and V_o is output voltage. Furthermore, D is operating duty cycle, I_{in} is input current and I_o is output current.

IV. DC BUS VOLTAGE REGULATION DESIGN EXAMPLE USING SEPIC DC-DC CONVERTER

As a design example of a dc bus voltage regulator, SEPIC converter has been used in this paper. The choice of SEPIC converter has no particular major basis except for its two features namely buck-boost characteristics and non-reversal of voltage polarity between input and output. In this design example the following assumptions were made.

- (i) The DC voltage bus which is coupled with storage system is able to absorb all the energy produced by the renewable sources to the load and storage system.
- (ii) The DC voltage bus is able to supply the energy required by the connected load.

It is therefore the function of the SEPIC converter to feed the DC voltage bus with constant voltage as set by the DC bus. Fig. 2 depicts power circuit diagram of a SEPIC converter. The converter parameters are listed in the appendix.

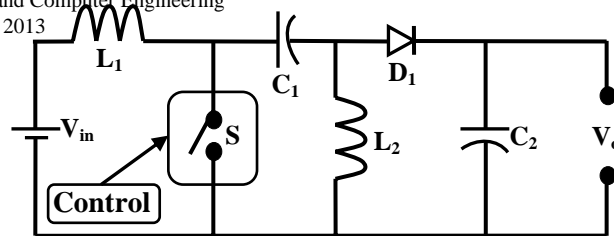

Fig. 2 Circuit Diagram of SEPIC Converter

The SEPIC converter used in the design example is rated at 400V output regulated DC voltage and up to 100A output (load) current which amount to 40kW maximum output power. The circuit parameters used in off-line and Real-Time Simulations are shown in the appendix. MATLAB/SIMULINK-Sim Power System version 7.10 was used to model the power circuit of the SEPIC converter [15]. The operational characteristics of the SEPIC converter have been well covered in the literature [12]-[14].

The main purpose of this research work is to investigate the capability of the DC bus voltage regulator to regulate the dc voltage fed to the DC busbar irrespective of voltage variation output of the renewable energy sources such as Solar and Wind. Fig. 3 shows a feedback control block diagram of the SEPIC converter fed by varying DC voltage. In Fig. 3, a PI controller was used with suitably chosen parameters. It should be noted that, at this stage there was no attempt to analytically optimise the control parameters of the regulator. The control parameters of the regulator are given in the appendix.

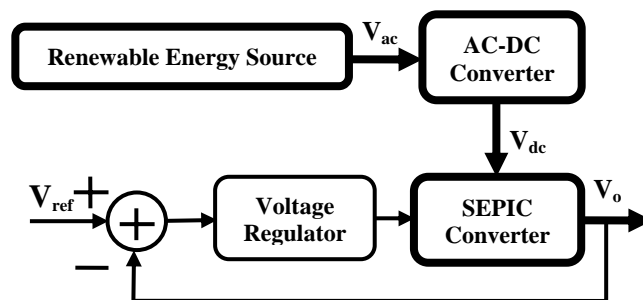

Fig. 3 DC voltage regulator based on SEPIC converter

V. OFF-LINE SIMULATION OF DC VOLTAGE REGULATOR

The SEPIC converter power circuit and the controller were modelled using MATLAB/SIMULINK-Sim Power System version 7.10 [15]. Off-line simulations of the DC bus voltage regulator (SEPIC converter power circuit and the controller) system were conducted using discrete fixed step simulation mode in order to imitate and prepare for real-time simulation and possibly hardware implementation.

The purpose of running off-line simulations was mainly to evaluate the suitability of fixed time step used in terms of convergence of numerical computation in the computer before running the simulations in the Real-Time Digital Simulator. In this case a time step of 50µs was found to be adequate in terms of computational accuracy of the system signals. Extensive off-line simulations were conducted aiming at obtaining system parameters which gave best possible results. The results obtained from off-line

simulations were used to determine suitable system parameters for best results and therefore are not included in this paper.

VI. REAL-TIME SIMULATION RESULTS OF DC VOLTAGE REGULATOR

Results obtained from off-line simulations guided the researcher to further implement the system in RT-LAB Real-Time Digital Simulator from OPAL-RT Technologies Incorporation [16]. The Real-Time Digital Simulator accepts MATLAB/SIMULINK models as input and runs the simulations in real time. The importance of Real-Time Simulation is that, for well modelled system, the results obtained can be treated as almost the same as results obtained from real hardware. In order to test the performance of the DC bus voltage regulator, voltages of varying ripple magnitude and frequency were used as test input voltages.

Fig. 4 shows Real-Time simulation results for relatively slow varying input DC voltage. It can be seen that the DC voltage regulator is capable of regulating the output DC voltage within less than 2% of the intended DC bus voltage. Also, it can be seen that the DC voltage regulator is capable of regaining voltage regulation after step change of the load connected to the DC voltage bus.

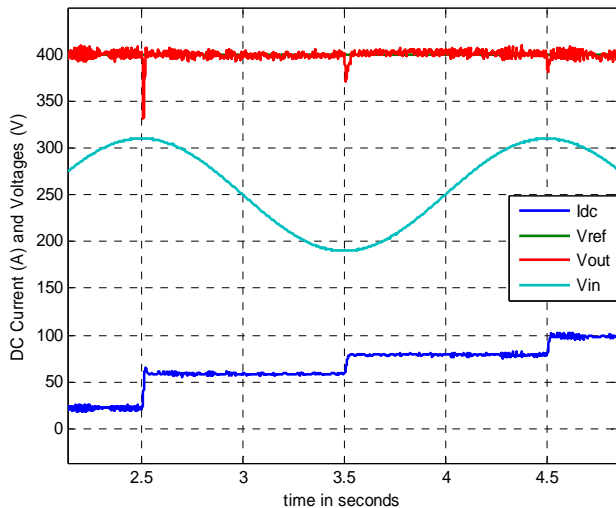

Fig. 4 Real-Time Simulation results for slow changing input voltage

Fig. 5 shows Real-Time simulation results for fast varying input DC voltage. It is evident that the DC voltage regulator is rugged and capable of regulating the output DC voltage but with high ripple amplitude.

The test results in Fig. 5 show extreme situation where the ripple of the input DC voltage varies at a frequency of 5Hz with peak-to-peak amplitude of 120V. In real situation, this type of voltage variation from renewable energy source is unlikely to happen. In that case the envisioned DC bus voltage regulator is adequately rugged for use in real situations.

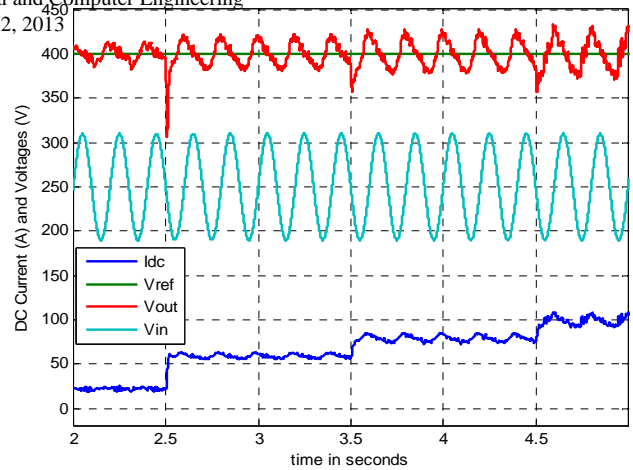

Fig. 5 Real-Time Simulation results for fast changing input voltage

Fig. 6 depicts expanded time scale of DC voltage dip showing a voltage dip caused by a step load increase. It can be observed that the regulator is capable to regain DC voltage regulation within 20ms based on the presented design example.

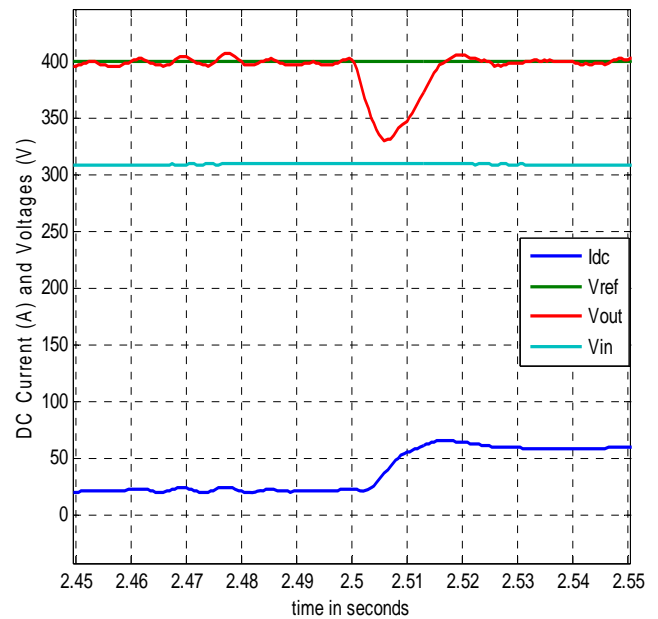

Fig. 6 Expanded time scale showing voltage dip due to step load increase

The proposed regulator is envisaged to handle various types of DC voltages including rectifier output of varying magnitude voltage from wind turbine coupled generator. In this case, the DC voltage of the rectifier contains high frequency ripple of the rectifier superimposed on a slow magnitude varying voltage. This scenario is shown in Fig. 7. It is evident from Fig. 7 that the proposed regulator is capable to maintain the DC voltage within small ripple around the set reference value, in this case 400V. Fig. 8 depicts expanded time scale of DC voltage dip showing a voltage dip caused by a step load increase. It can be observed that the regulator is capable to regain DC voltage regulation within the same 20ms as in Fig. 6.

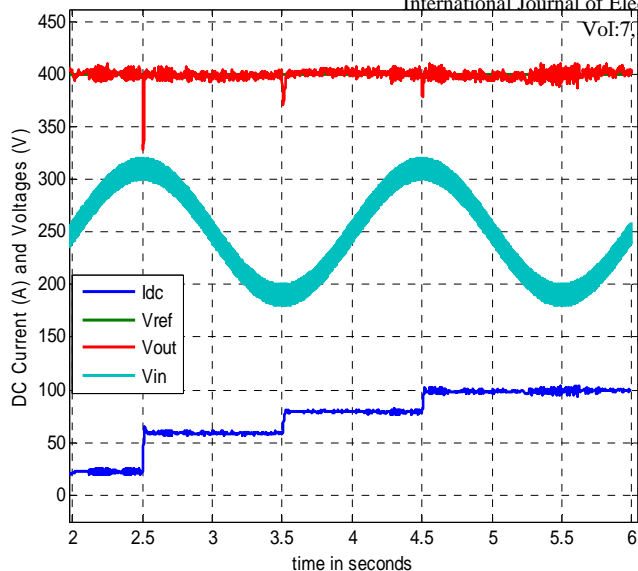

Fig. 7 Real-Time Simulation results for varying magnitude input voltage with superimposed ripple

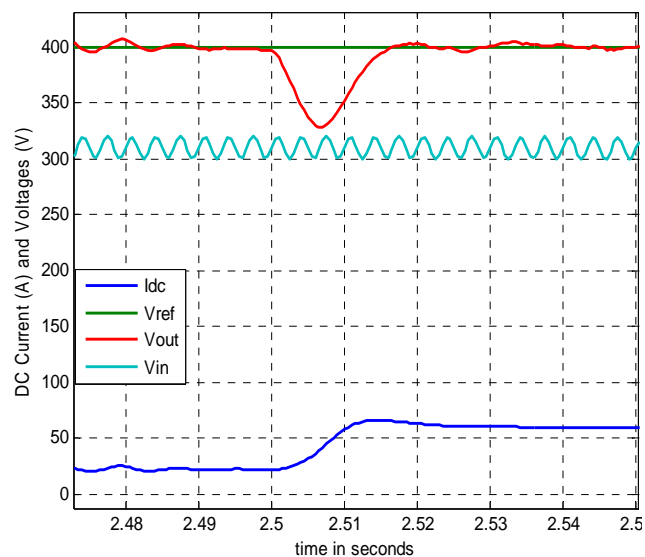

Fig. 8 Expanded time scale showing voltage dip due to step load increase for varying magnitude input voltage with superimposed ripple

VII. CONCLUSIONS

This research work aimed at designing a constant DC voltage bus which is used to interface between the stochastically varying voltages from renewable energy sources and the loads which necessarily require standard DC or AC supply. This research is important as part of global research works on renewable energy sources, conversion and integration technologies.

The methodologies used in this research work are modeling of the DC voltage regulation system, off-line simulations and then Real-Time simulations of the model. The results obtained from Real-Time simulations of DC voltage regulator show that the regulator is rugged against variation of input voltage as well as step load changes.

The proposed regulator is suitable for synthesis of asynchronous DC busbar which can be used to integrate several renewable energy sources with varying characteristics. For the purpose of inclusion of Maximum

Power Point Tracking (MPPT) in some systems, the proposed DC voltage regulation system can be deployed in front of the MPPT device.

ACKNOWLEDGMENT

The author is grateful for financial support extended by Sida from Sweden.

APPENDIX

Power Circuit: L_1 : 0.25Ω, 1.5H, C_1 : 50mF; L_2 : 1.0Ω, 5Mh, C_2 : 20mF.

PI Controller Parameters: $K_p = 0.25$, $K_i = 5.0$.

REFERENCES

- [1] Alliance for Rural Electrification (ARE) –USAID, DFID A Potential Role for AMCs in Promoting Green Mini-Grids in Tanzania CASE STUDY ANNEX March 2010.
- [2] Clean Energy Ministerial, Roundtable 6: Mini-Grid Development Session Structure for the Public-Private Roundtable, 16:15-17:45, 17 April 2013, New Delhi, India.
- [3] International Energy Agency, "Overview of Supervisory Control Strategies Including a MATLAB/Simulink Simulation Tool," Photovoltaic Power Systems Programme, Report IEA-PVPS T11-08:2012, August 2012.
- [4] International Energy Agency, "Sustainability Conditions for PV Hybrid Systems: Environmental Considerations," Photovoltaic Power Systems Programme, Report IEA-PVPS T11-03:2011, March 2011.
- [5] Sanjeev Pokhrel, S. K. Singal and S. N. Singh, "Comprehensive Study of Community Managed Mini Grid," International Journal of Emerging Technology and Advanced Engineering Volume 3, Special Issue 3: ICERTSD 2013, Feb 2013, pages 514-520.
- [6] CAMCO-UNDP-Climate Parliament, "Mini-Grid Toolkit Field Study Report for Kenya, Mozambique and Zambia," Field Study Report.
- [7] W. He "Grid Interaction of DG Units with Power Electronic Interfaces", Master Thesis, Electrical Machines and Power Electronics, Department of Electrical Engineering, Royal Institute of Technology, Stockholm Sweden.
- [8] Brisa Ortiz, "Off-grid and mini grid PV systems for electrification: advantages and challenges," Fraunhofer Institute for Solar Energy Systems, Accra, November 2, 2012.
- [9] International Energy Agency, "World-Wide Overview of Design and Simulation Tools for Hybrid PV Systems," Photovoltaic Power Systems Programme, Report IEA-PVPS T11-01:2011, January 2011.
- [10] N. Mohan, T. M. Undeland, and W. P. Robbins, Power Electronics: Converters, Applications and Design, Third Edition, John Wiley, New York, 2003.
- [11] M. H. Rashid, Power Electronics, Circuits, Devices and Applications, Third Edition, Prentice Hall, Upper Saddle River, NJ, 2004.
- [12] Ray Ridley, "Analyzing the SEPIC converter," Switching Power Magazine, Nov. 2006, pp.1- 38.
- [13] Jeff Falin, "Designing DC/DC converters based on SEPIC topology," Analog Applications Journal-Power Management, Texas Instruments Incorporated, 2008, pp. 18-23.
- [14] Binod Kumar Padhi, Anirudha Narain, "Controller Design for Sepic Converter Using Model Order Reduction," International Journal of Electrical, Electronics and Data Communication, Vol. 1, Issue- 3.
- [15] The Mathworks, "MATLAB/SIMULINK." Version 7.10.
- [16] OPAL-RT Technologies Inc "RT-LAB", version10.4.9.